

# LPT

## COOLING TOWERS

**Eurovent-CTI  
CERTIFIED**



**LOW PROFILE IN  
FORCED DRAFT, COUNTERFLOW COOLING TOWERS  
Thermal Performance from 120 to 1460 kW Nominal Capacity**

*DELIVERING QUALITY... FOCUSED ON PERFECTION!*

**CERTIFIED EN ISO 9001**



Mark owned by the Cooling Technology Institute



# LPT



Since its founding in 1976, EVAPCO, Inc. has become a world-wide leader in supplying quality cooling equipment for thousands of customers in both the commercial and industrial markets.

EVAPCO's success has been the result of a continual commitment to product improvement, quality workmanship and a dedication to providing unparalleled service.



Our emphasis on research and development has led to many product innovations – a hallmark of EVAPCO through the years.

The ongoing R & D Program enables EVAPCO to provide the most advanced products in the industry – technology for the future, available today.

EVAPCO products are manufactured on five continents around the world and distributed through hundreds of factory authorized sales representatives.

The new & improved EVAPCO Model LPT forced draft centrifugal cooling towers now feature IBC Compliance in addition to ECC-CTI Certification. These features reinforce EVAPCO's position as the leading manufacturer of forced draft evaporative cooling equipment.

### Z-725 Heavy Mill Galvanized Steel Construction

(Stainless steel available as an affordable option)

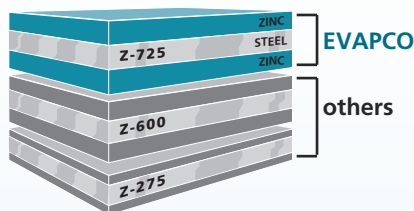

### Double-Brake Flange Joints

- Stronger than single-brake designs by others
- Increases field rigging joint integrity
- Greater structural integrity

### Stainless Steel Strainer

- Resists corrosion better than other materials

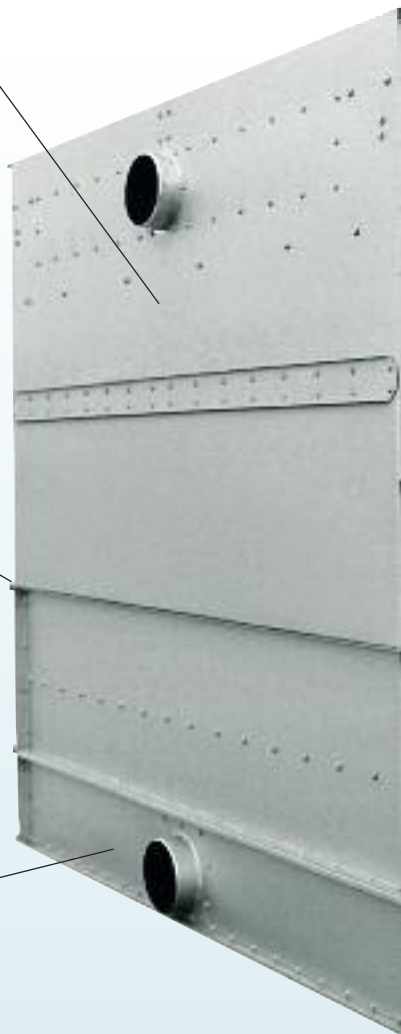

**ECC-CTI Certified**  
Refer to page 13 for details



† Mark owned by the Cooling Technology Institute

# DESIGN AND CONSTRUCTION FEATURES



**IBC Compliant Design**  
 Refer to page 11 for details

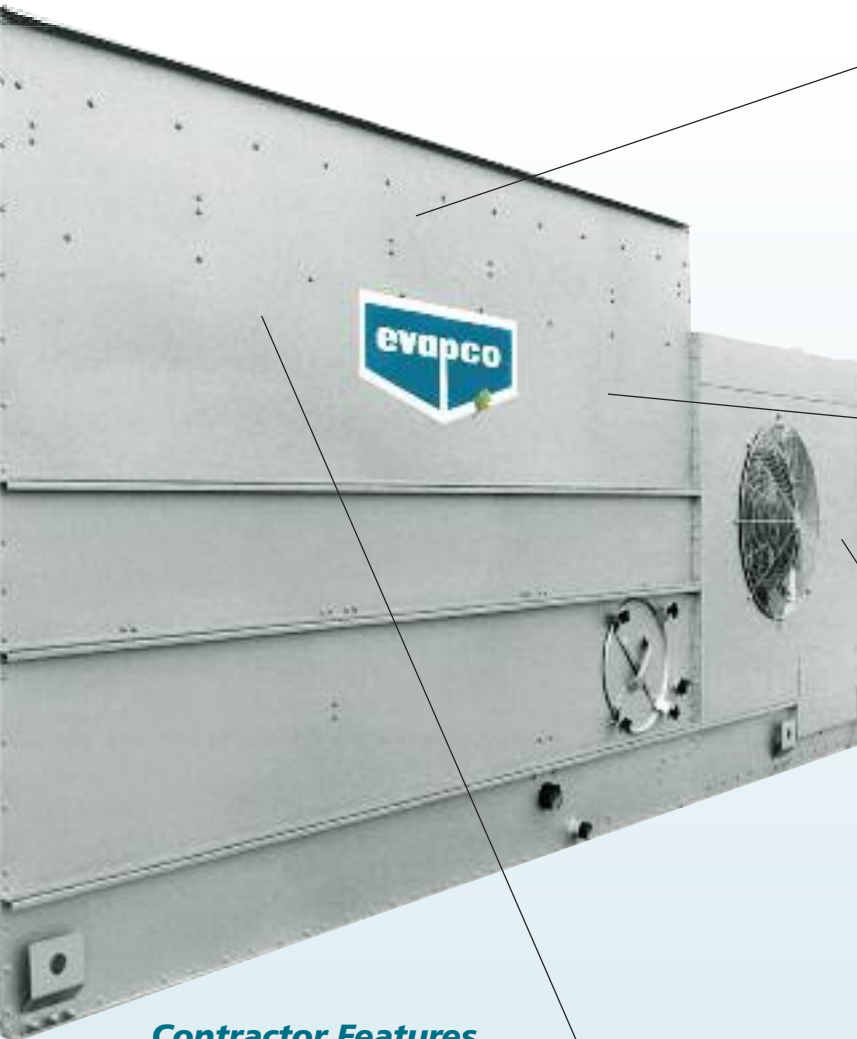

### Contractor Features

- Low Rigging Cost
- Low Installation Cost

### Owner Features

- Low Profile (low height)
- Low Maintenance

### Engineering Features

- CTI Certified Performance
- Lowest Sound with Full Attenuation
- IBC Compliant Design

### Water Saver Drift Eliminators

- New patented design reduces drift rate to < 0.001%
- Saves water and reduces water treatment cost
- Greater structural integrity vs. old style blade-type
- Recessed into casing for greater protection

### Exclusive EVAPAK® fill

- Provides the most efficient thermal performance per plan area
- Suitable for use as a working platform

### Totally Enclosed Fan Motors & Superior Drive System

- Assures long life
- Located in dry, incoming air-stream, allowing normal maintenance to be done from the outside of the unit
- If required, motor can be easily removed
- Solid fan shaft
- Belt tensioning and bearing lubrication can be performed from outside the unit
- Motor is fully accessible by removing one inlet screen

### PVC Spray Distribution Header

- Nozzles are threaded into the header to ensure proper orientation.
- Fixed position nozzles require little maintenance.
- Large orifice nozzle with integral sludge ring to prevent clogging.

# LPT

## DESIGN FEATURES

### Reduced Height and Improved Maintenance Accessibility

The LPT unit has been designed to satisfy installation requirements where height limits must be observed. The lower profile design of the LPT does not, however, sacrifice maintenance accessibility for reduced height. Its unique casing design allows the water distribution system, cold water basin, fan section and other unit components to be easily maintained.

Small, light weight sections of the drift eliminators can be easily removed to access the water distribution system. Large circular access doors are located on both sides of the cold water basin to allow adjustment of the float assembly, removal of the stainless steel strainers and cleaning of the basin. The fan motor and drive system are located at one end of the unit and are completely accessible by removing the inlet screens. Although, routine maintenance can be performed from the exterior of the unit without removing the inlet screens.

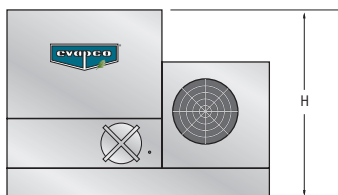

### Cold Water Basin Access

The LPT cold water basin can be easily maintained from the sides of the cooling tower through large, circular access doors. The unique stepped configuration of the LPT heat transfer section allows unimpeded access to the basin to allow adjustment of the float assembly, removal of the stainless steel strainers and basin cleaning.



### Mechanical Drive System Access

The LPT mechanical drive system is easy to maintain. Bearing lubrication and belt adjustment can be performed from outside the unit. There is no need to remove fan screens to maintain important



drive components. In addition, the locking mechanism used to maintain belt tension can also work as a wrench to adjust the belt.

### Motor Location

All LPT models have TEFC motors mounted on adjustable motor bases, similar in design to the large EVAPCO AT Cooling Tower Drive System. This same technology has been utilized in the LPT design to allow belt adjustment to be performed externally. In addition, the motor is located under the protective fan system enclosure and can be easily accessed by removing one air inlet screen.

### Fan Access-Split Housing

Another unique feature of the LPT Cooling Towers are split fan housings. The split fan housing on the LPT allows quick removal of the fans from the front end of the unit. This feature allows fan removal when units are placed side by side where space is minimal.

### Transport of a Pre-Assembled Unit

The LPT ships fully assembled. This means lower transport costs and no further expenses at the job site for assembly. LPT units are ideal for truck-mounted applications for remote sites or temporary installations.

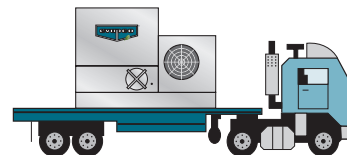

### Efficient Drift Eliminators\*

An extremely efficient drift eliminator system is standard on the LPT Cooling Tower. The system removes entrained water droplets from the air stream to limit the drift rate to less than 0.001% of the recirculating water rate. With a low drift rate, the LPT Cooling Tower saves valuable water and water treatment chemicals. The LPT can be located in areas where minimum water carryover is critical, such as parking lots. The drift eliminators are constructed of an inert polyvinyl chloride (PVC) plastic material which effectively eliminates corrosion of these vital components. They are assembled in sections to facilitate easy removal for inspection of the water distribution system.

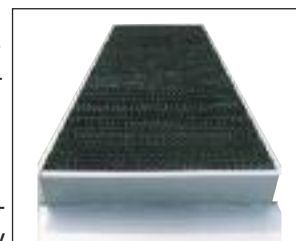

\* US Patent No. 6315804B1

## DESIGN FEATURES

# LPT

### EVAPCOAT:

#### Z-725 Hot-Dip Galvanized Steel Construction

The Z-725 Mill Hot-Dip Galvanized Steel Construction is the heaviest level of galvanizing available for manufacturing evaporative cooling towers and has more zinc protection than competitive designs using Z-275 and Z-600 steel.

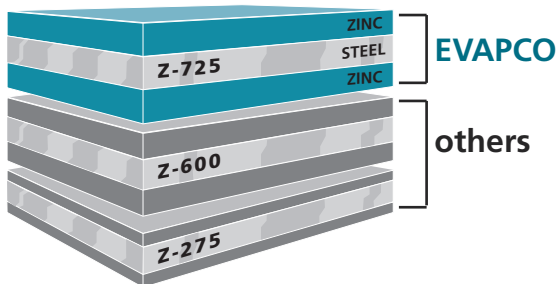

EVAPCO has been a leader in the industry in developing heavier galvanizing, and was the first to standardize on Z-725 mill hot-dip galvanized steel. Z-725 designation means there is a minimum of 725 g of zinc per m<sup>2</sup> of surface area present on the steel.

During fabrication, all panel edges are coated with a 95% pure zinc-rich compound for extended corrosion resistance.

**The EVAPCOAT Corrosion Protection System is the heaviest galvanized coating available for extended corrosion protection eliminating the need for costly, unreliable epoxy paint finishes.**

#### Stainless Steel Material Options

The EVAPCOAT Corrosion Protection System is satisfactory for most applications. If additional corrosion protection is required the following stainless steel options are available (AISI 304 and 316). Please contact your local EVAPCO representative for pricing.

Consult the factory for construction details.

### EVAPAK® Cooling Tower Fill

The patented\* EVAPAK® fill design used in the forced draft cooling tower line is the culmination of thousands of hours of research and testing conducted by EVAPCO's research engineers. This program has produced a cooling tower fill with superior heat transfer, reduced channeling in flow passages, improved drip enhancement for lower air side pressure drop and exceptional structural strength.

The fill is specially designed to induce highly turbulent mixing of the air and water for heat transfer. This is made possible by forming the raw fill into corrugated panels on which there are small ridges. These ridges serve many purposes, one of which is to create agitation in both the water and the air in the tower. This increase in turbulence prevents channeling of the water and promotes better mixing of air and water, therefore improving heat transfer. In addition, special drainage tips allow high water loadings without excessive pressure drop.

The fill is constructed of inert polyvinyl chloride, (PVC). It will not rot or decay and is formulated to withstand water temperatures of 55°C. Because of the unique way in which the cross-fluted sheets are bonded together, the structural integrity of the fill is greatly enhanced, making the fill usable as a working platform.

A high temperature fill is available for water temperatures exceeding 55°C.

Consult your EVAPCO representative for further details.

EVAPAK® FILL

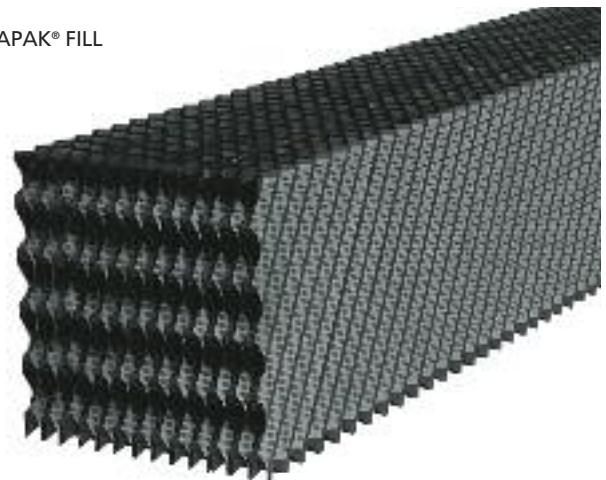

\*U.S. Patent No. 5,124,087

# LPT

## OPTIONAL EQUIPMENT

### Pan Freeze Protection

#### Remote Sump

Whenever a cooling tower is idle during sub-freezing weather, the water in the sump must be protected from freezing and damaging the pan. The simplest and most reliable method of accomplishing this is with a remote sump tank located in a heated space in the building under the tower. With this system, the water in the tower drains to the indoor tank whenever the pump is shut-off. When a tower is ordered for remote sump operation, the standard float valve and strainer are omitted, and the unit is provided with an oversized water outlet connection. When a remote sump is not possible, a supplementary means of heating the pan water must be provided.

#### Electric Heaters

Electric immersion heaters are available factory installed in the basin of the tower. They are sized to maintain a +5°C pan water temperature at 18°C ambient with the fans off. They are furnished with a combination thermostat/low water protection device to cycle the heater on when required and to prevent the heater elements from energizing unless they are completely submerged. All components are enclosed in rugged, weather proof enclosures for outdoor use. Heater control packages are available as an option. Contact your local EVAPCO representative for further details.

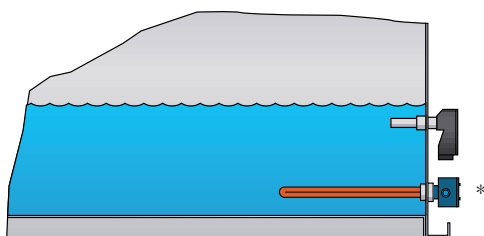

BASIN HEATER

\*See factory certified prints for detailed drawings.

#### Electric Pan Heaters

Model No.	KW
LPT 316 to 366	(1) 2
LPT 516 to 596	(1) 3
LPT 519 to 569	(1) 4
LPT 5112 to 5712	(1) (6)
LPT 819 to 879	(1) (7)
LPT 8112 to 8812	(1) (9)

\* Electric heater selection based on -18°C ambient temperature. For alternate low ambient heater selections, consult the factory.

#### Electric Water Level Control

EVAPCO LPT Cooling Towers are available with an optional electric water level control system in place of the standard mechanical makeup valve and float assembly. This package provides accurate control of the pan water level and does not require field adjustment, even under widely variable operating conditions.

The control was designed by EVAPCO and consists of multiple heavy duty stainless steel electrodes. These electrodes are mounted external to the unit in a vertical stand pipe. For winter operation, the stand pipe must be wrapped with electric heating cable and insulated to protect it from freezing.

The weather protected slow closing solenoid valve for the makeup water connection is factory supplied and is ready for piping to a water supply with a pressure between 140 (minimum) and 350 kPa (maximum).

#### Vibration Isolators

The fans on EVAPCO cooling towers are balanced and run virtually vibration free. In addition, the rotating mass is very small in relation to the total mass of the cooling tower, further reducing the possibility of objectionable vibration being transmitted to the building structure. As a result, vibration isolation is generally not required.

In those cases where it is determined that vibration isolation is necessary, spring type vibration isolator rails can be furnished. The rails are constructed of heavy gauge Z-725 hot-dip galvanized steel for superior corrosion resistance. Rails are designed to be mounted between the cooling tower and the supporting steel framework. They are 90% efficient and have approximately 25 mm static deflection. Rails are designed for wind loading up to 80 km/h.

It is important to note that vibration isolation must be installed continuously along the full length of the cooling tower on both sides of the unit. Point isolators may be used between the supporting steel and the building framework, but not between the unit and the supporting steel.

**IBC Certification cannot be given when vibration isolators are installed.**

#### Other Options Available:

- Pony Motors
- Stainless Steel Material Options
- Tapered Discharge Hoods
- Solid Bottom Panels for Ducted Applications
- Fill Access Doors

# LPT

## APPLICATIONS

### LPT Ships Factory Assembled

The compact, unitary design of the LPT Cooling Tower allows them to be shipped completely assembled. This results in lower transportation costs and no assembly requirements at the job site. Only one lift is required to rig the LPT.  
*Note: Options such as attenuation and discharge hoods will require additional lifts.*

### Structural Steel Support

The recommended method of support for the LPT cooling tower is two structural "I" beams located under the outer flanges and running the entire length of the unit. Mounting holes 19 mm in diameter, are located at the bottom channels of the pan section to provide for bolting to the structural steel. Refer to certified drawings from the factory for bolt hole locations. See the drawing and chart below for unit dimensions.

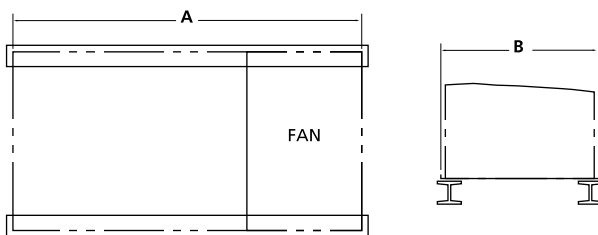

Model No.	Dimensions (mm)		B
	A (unit only)	A (with atten.)	
LPT 316 to 366	3096	4206	1029
LPT 516 to 596	3727	4842	1540
LPT 519 to 569	4629	5740	1540
LPT 5112 to 5712	5553	6664	1540
LPT 819 to 879	4629	5740	2388
LPT 8112 to 8812	5553	6664	2388

**Note:**

- 1) Beams should be level before setting the unit in place.
- 2) Do not level the unit by shimming between it and the "I" beams as this will not provide proper longitudinal support.
- 3) Beams should be sized in accordance with accepted structural practices. Support beams and anchor bolts are to be furnished by others.

### Indoor Installation

All LPT Cooling Towers can be installed indoors where they normally require ductwork to and from the unit. The design of the ductwork should be symmetrical to provide even air distribution across both intake and discharge openings. Guidelines for Ducted Applications:

- 1) The static pressure loss imposed by the ductwork must not exceed 120 Pa. The fan motor size must be increased for ESP up to 120 Pa.

- 2) For ducted installations, the solid bottom panel option must be ordered. A blank off plate will also be provided in lieu of the side air inlet screens with this option.
- 3) Important, Access Doors must be located in the ductwork for service to the fan drive components and water distribution system.

Drawings are available showing recommended ductwork connections. See EVAPCO's Layout Guidelines for additional information.

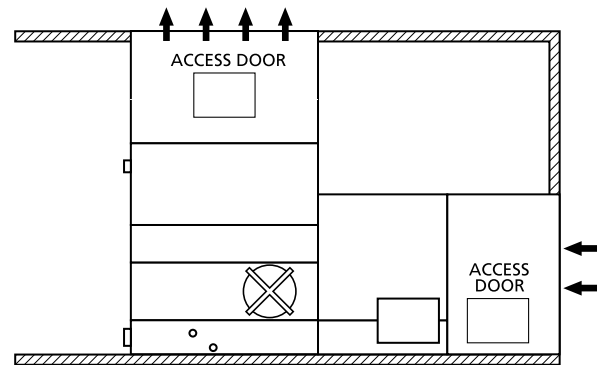

**Note:** Ductwork/solid bottom panels negate the CTI Certification.

### Design

EVAPCO LPT Cooling Towers have heavy-duty construction and are designed for long, trouble-free operation. However, proper equipment selection, installation and maintenance are necessary to insure good unit performance. Some of the major considerations in the application of a cooling tower are presented below. For additional information, contact the factory.

### Air Circulation

In reviewing the system design and unit location, it is important that enough fresh air is provided to enable proper unit performance. The best location is on an unobstructed roof top or on ground level away from walls and other barriers. Care must be taken when locating towers in wells or enclosures or next to high walls. The potential for recirculation of the hot, moist discharge air back into the fan intake exists. Recirculation raises the wet bulb temperature of the entering air causing the leaving water temperature to rise above design. For these cases, a discharge hood or ductwork should be provided to raise the overall unit height even with the adjacent wall, thereby reducing the chance of recirculation. For additional information see the EVAPCO Equipment Layout Manual. Engineering assistance is also available from the factory to identify potential recirculation problems and recommend solutions.

# LPT

## APPLICATIONS

### Capacity Control

The design wet bulb for which the cooling tower is sized occurs only a small percentage of the time. Unless colder water temperatures are beneficial to the process being cooled, some form of capacity control will be needed.

A common control practice is to cycle the fans off when leaving water is below the minimum allowable temperature. However this does not provide close control of the leaving water temperature and may cycle the motor on and off more than the recommended limit of six (6) starts per hour.

Another method is to use two-speed fan motors which add a second step of control. Two speed fan motors are an excellent method of capacity control for the LPT. This arrangement gives capacity steps of 10% (fans off), 60% (fans half-speed) and 100%. A temperature controller can be supplied to set control at 3 °C increments, so fairly close temperature control can be maintained without excessive cycling of the fan motor.

Two-speed motors also save operating costs. At half-speed the motor draws approximately 15% of full load power. Since maximum wet bulb and maximum load very seldom coincide on air conditioning systems, the cooling tower will actually operate at half speed 80% of the time. Thus, power costs will be reduced by approximately 85% during the major portion of the operating season.

**Caution: The water circulation pump must be interlocked with the fan motor starter(s) to insure water flow over the tower fill during fan operation.**

### Piping

Cooling tower piping should be designed and installed in accordance with generally accepted engineering practices. All piping should be anchored by properly designed hangers and supports with allowance made for possible expansion and contraction. No external loads should be placed upon cooling tower connections, nor should any of the pipe supports be anchored to the unit framework.

### Maintaining the Recirculated Water System

The cooling in a tower is accomplished by the evaporation of a portion of the recirculated spray water. As this water evaporates, it leaves behind all of its mineral content and impurities. Therefore, it is important to bleed-off an amount of water equal to that which is evaporated to prevent the buildup of impurities. If this is not done, the mineral content and/or the corrosive nature of the water will continue to increase. This will ultimately result in heavy scaling or a corrosive condition.

### Bleed-off

A bleed line should be installed in the piping, external to the unit. The bleed line must be properly sized for the application and provided with a metering connection and globe valve. The recommended bleed off for a cooling tower is equivalent to the evaporation rate of 1,58 l/h per kW of cooling. If the make-up water supplying the unit is relatively free of impurities, it may be possible to cut back the bleed, but the unit must be checked frequently to make sure scale is not forming. Make-up water pressure must be maintained between 140 and 340 kPa for proper operation of the float valve.

### Water Treatment

In some cases the make-up water will be so high in mineral content that a normal bleed-off will not prevent scaling. In these cases water treatment will be required and a reputable water treatment company familiar with the local water conditions should be consulted.

Any chemical water treatment used must be compatible with the stainless and galvanized construction of the unit. The pH of the water should be maintained between 7.0 and 8.8. In order to prevent "white rust", the galvanized steel in the unit requires routine passivation of the steel when the system is operating in higher pH levels. Batch chemical feeding is not recommended because it does not afford the proper degree of control. If acid cleaning is required extreme caution must be exercised and only inhibited acids compatible with galvanized steel construction should be used.

### Control of Biological Contamination

Water quality should be checked regularly for biological contamination. If biological contamination is detected, a more aggressive water treatment and mechanical cleaning program should be undertaken. The water treatment program should be performed by a qualified water treatment company and in accordance with relevant local legislation. It is important that all internal surfaces be kept clean of accumulated dirt and sludge. In addition, the drift eliminators should be maintained in good operating condition.

**Note: The location of the cooling tower must be considered during the equipment layout stages of a project. It is important to prevent the discharge air (potential of biological contamination) from being introduced into the fresh air intakes of the building.**



# LPT



The LPT Cooling Tower is now available with sound attenuators to reduce the overall sound generated from the side or top of the Cooling Tower. Each option provides various levels of sound reduction and can be used in combination to provide the lowest sound level.

## Ultra Quiet Cooling Towers

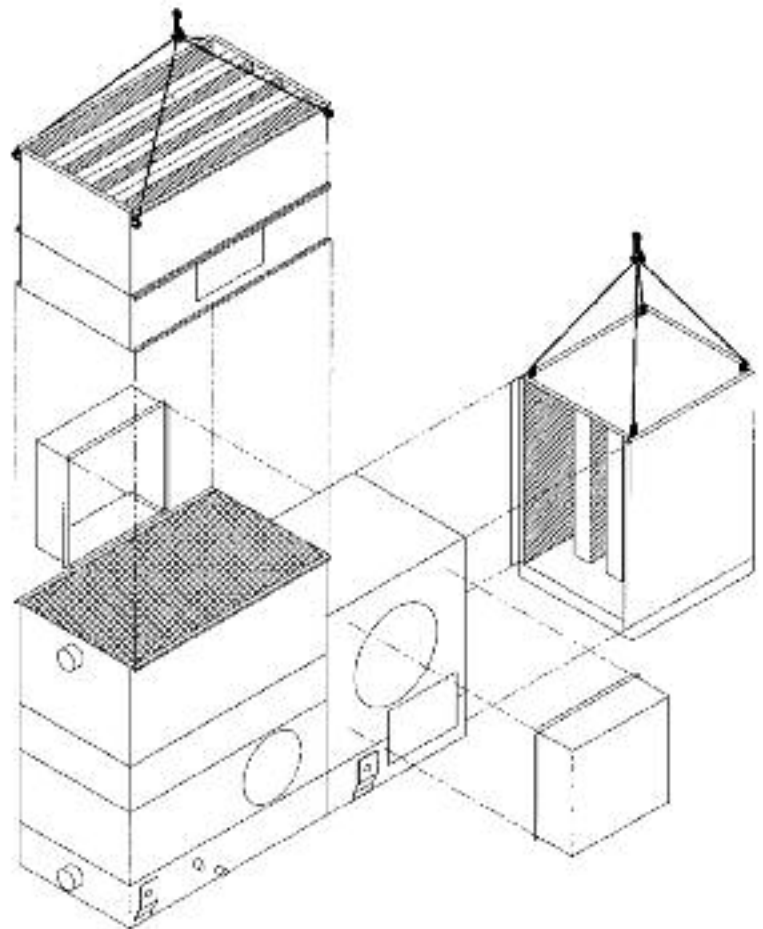

**Cooling Tower  
attenuation with  
CTI Performance  
Certification**

SOUND

# LPT

## DISCHARGE & INTAKE ATTENUATION DIMENSIONS

### Sound Attenuation

The standard LPT is the quietest, low profile centrifugal fan cooling tower in the industry. This is achieved by providing the first stage of inlet sound attenuation as part of the LPT's standard design. The LPT drive system, including the fan housing(s), electric motors, belts, bearings and drives, is completely enclosed by a



protective housing which covers the drive system and also provides a significant level of sound reduction. If the standard LPT sound pressure level is not quiet enough for certain applications, the sound levels can be further reduced by adding various stages of sound attenuation. Consult the factory for Factory Certified Sound Data for each option. Please refer to Evapco's selection software for correct model number designation and CTI Certified performance.

LPT Discharge Attenuation Dimensions\*

Model Name	H1 (mm)	L1 (mm)	W1 (mm)	Weight per attenuat. (kg)	Number of attenuators
LPT 3x6	1102	1822	1029	195	1
LPT 5x6	1102	1822	1540	240	1
LPT 5x9	1102	2724	1540	327	1
LPT 5x12	1102	3648	1540	417	1
LPT 8x9	1102	2724	2388	440	1
LPT 8x12	1102	3648	2388	558	1

LPT Intake Attenuation Dimensions\*

Model Name	H2 (mm)	L2 (mm)	W2 (mm)	Weight per attenuat. (kg)	Number of attenuators
LPT 3x6	1622	1029	1108	204	1
LPT 5x6	2022	1540	1105	313	1
LPT 5x9	2022	1540	1105	313	1
LPT 5x12	2022	1540	1105	313	1
LPT 8x9	2022	2394	1108	417	1
LPT 8x12	2022	2394	1108	417	1

LPT Fan Side Attenuation Dimensions\*

Model Name	H3 (mm)	L3 (mm)	W3 (mm)	Weight per Attenuat. (kg)	Number of Attenuators
LPT 3x6	854	1645	883	68	2
LPT 5x6	936	2155	1372	104	2
LPT 5x9	936	2155	1372	104	2
LPT 5x12	936	2155	1372	104	2
LPT 8x9	1075	3010	1121	104	2
LPT 8x12	1075	3010	1121	104	2

\*Attenuation dimensions may vary slightly from catalog. See factory certified prints for exact dimensions.

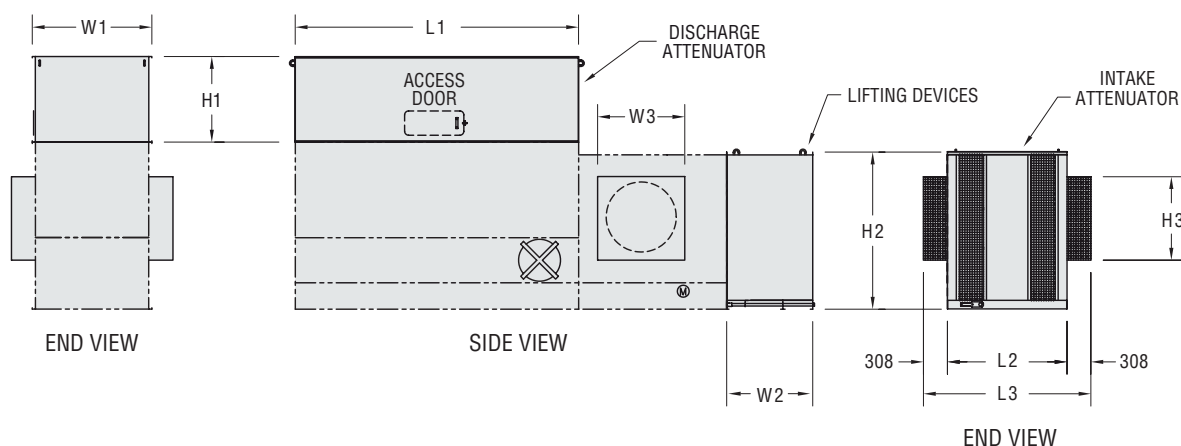

LPT Attenuation

† Mark Owned by the Cooling Technology Institute.

# LPT

## We Stand Tall Through it All!



The International Building Code (IBC) is a comprehensive set of regulations addressing the structural design and installation requirements for building systems – including HVAC and industrial refrigeration equipment.

With the advent of the IBC, EVAPCO is proud to introduce the LPT Cooling Towers with IBC compliance standard.



## Wind, Rain, Earthquake and Hurricane

*EVAPCO Cooling Towers... designed to withstand seismic or wind load forces.*

# LPT

## IBC COMPLIANCE

In its continuing commitment to be the leaders in evaporative cooling equipment design and services, EVAPCO LPT Cooling Towers are now **Independently Certified** to withstand Seismic and Wind Loads in accordance with IBC.

### What is IBC?

#### International Building Code

The International Building Code (IBC) is a comprehensive set of regulations addressing both the structural design and the installation requirements for building systems – including HVAC and industrial refrigeration equipment.

Compared to previous building codes that considered only the building structure and component anchorage, the requirements contained within the IBC address anchorage, structural integrity, and the operational capability of a component following either a seismic or wind load event. **Simply stated, the IBC code provisions require that evaporative cooling equipment, and all other components permanently installed on a structure, must be designed to meet the same seismic or wind load forces as the building to which they are attached.**

#### How Does IBC Apply to Cooling Towers?

Based on site design factors, calculations are made to determine the equivalent seismic “g force” and wind load (kilo-Newton per square meter, kN/m<sup>2</sup>) on the unit. The cooling tower must be designed to withstand the greater of either the seismic or wind load.

All locations with design criteria resulting in a seismic design force of up to 1.0g or a wind load of 2,87 kN/m<sup>2</sup> or below will be provided with the standard LPT structural design. An upgraded structural design is available for installations with design criteria resulting in “g forces” greater than 1.0g. The highest “g force” location in North America is 5.12g. The highest wind load shown on the maps is 273 km/h, which is approximately equal to 6,94 kN/m<sup>2</sup> velocity pressure. **Therefore, the upgraded structural design package option for the LPT is designed for 5.12 g and 6,94 kN/m<sup>2</sup> making it applicable to ALL building locations in North America.**

#### Design Implementation

EVAPCO applies the seismic design and wind load information provided for the project to determine the equipment design necessary to meet IBC requirements. This process ensures that the mechanical equipment and its components are compliant per the provisions of the IBC as given in the plans and specifications for the project.

#### Independent Certification

Although the IBC references and is based on the structural building code ASCE 7, many chapters and paragraphs of ASCE 7 are superseded by the IBC, independent certification and methods of analysis are such paragraphs. Per the most recent edition of the code, the EVAPCO compliance process included an exhaustive analysis by an independent approval agency. As required by the

International Building Code, EVAPCO supplies a certificate of compliance as part of its submittal documents. The certificate of compliance demonstrates that the equipment has been independently tested and analyzed in accordance with the IBC seismic and wind load requirements. Evapco has worked closely with the independent approval agency, The VMC Group, to complete the independent equipment testing and analysis.

For further questions regarding IBC compliance, please contact your local EVAPCO Representative.

# LPT



## Eurovent-CTI Certified LPT Cooling Towers

ECC-CTI

### CTI Standard 201

This standard sets forth a program whereby the Cooling Technology Institute will certify that all models of a line of evaporative heat rejection equipment offered for sale by a specific manufacturer will perform thermally in accordance with the manufacturer's published ratings...



***Technology for the Future,  
Available Today!***



† Mark owned by the Cooling Technology Institute

In its continuing commitment to be the leaders in evaporative cooling equipment design and services, EVAPCO LPT Cooling Towers are now **Independently Certified** by CTI, to perform thermally in accordance with the published data.

## What is CTI?

### Cooling Technology Institute

The Cooling Technology Institute is an organization headquartered in the United States with over 400 member companies from around the globe. CTI membership is composed of manufacturers, suppliers, owner operators, and test agencies from over 40 countries. In 2008 CTI certified more than 5000 Evaporative Heat Transfer Systems (EHTS) from 49 product line of 24 participants.

### CTI's Mission and Objectives

This can be best explained by the CTI's published Mission statement and Objectives revised in December 2003 and published on their website [www.cti.org](http://www.cti.org).

#### CTI Mission Statement

To advocate and promote the use of environmentally responsible Evaporative Heat Transfer Systems (EHTS) for the benefit of the public by encouraging:

- Education
- Research
- Standards Development and Verification
- Government Relations
- Technical Information Exchange

#### CTI Objectives

- Maintain and expand a broad base membership of individuals and organizations interested in Evaporative Heat Transfer Systems (EHTS).
- Identify and address emerging and evolving issues concerning EHTS.
- Encourage and support educational programs in various formats to enhance the capabilities and competence of the industry to realize the maximum benefit of EHTS.
- Encourage and support cooperative research to improve EHTS technology and efficiency for the long-term benefit of the environment.
- Assure acceptable minimum quality levels and performance of EHTS and their components by establishing standard specifications, guidelines, and certification programs.
- Establish standard testing and performance analysis systems and procedures for EHTS.
- Communicate with and influence governmental entities regarding the environmentally responsible technologies, benefits, and issues associated with EHTS.
- Encourage and support forums and methods for exchanging technical information on EHTS.

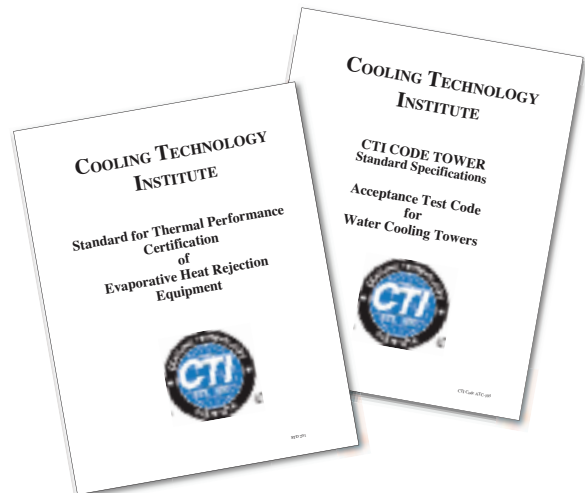

### Benefits to the End User

CTI defines an independent testing certification program that is specifiable, enforceable and available to all equipment manufacturer's. End users that purchase CTI certified products are assured that those products will perform thermally as specified.

Additionally CTI certification is the first step for the Green Building Concept in Europe:

- LEED - Leadership in Energy and Environmental Design
- Best Available Practice
- Green Building Rating System

### Thermal Performance Guarantee

In addition to the CTI Certification, Evapco unequivocally guarantees the Thermal Performance of ALL Evapco Equipment. Every unit order is confirmed with a submittal package that includes an Evapco Thermal Performance Guarantee Certificate.



# CTI CERTIFICATION

# LPT

## CTI Certification Program

### CTI Certification Process

- Submit Application for Certification
- CTI completes a technical review of the product line submitted
- CTI performs an initial qualification test in a laboratory on a specified model number
- CTI issues an Approval Letter with Validation Number if test is passed. Letter is also distributed to all members of CTI to inform everyone that a successful certification has been completed. The Certification Validation Number assigned should be fixed to each tower sold and displayed in all catalogs and other literature
- Product Line must undergo an Annual Reverification Test - Different model number is selected every year
- More details can be found on the CTI website [www.cti.org](http://www.cti.org)

### CTI Certification Test Parameters

- Entering Wet Bulb temperature - 12.8°C to 32.2°C
- Cooling Range - Minimum of 2.2°C
- Cooling Approach - Minimum of 2.8°C
- Process Fluid Temperature - Maximum of 51.7°C
- Barometric Pressure - 91.4 to 105 kPa
- More details can be found on the CTI website [www.cti.org](http://www.cti.org)

### CTI Certification Limitations

- Specific manufacturer's product line name and model numbers
- Applicable only to product lines and model numbers submitted
- Multiple cell model numbers are allowed if the airflow is not affected or the configuration impact is included in the unit rating
- Optional accessories are allowed if the airflow is not affected or the accessory impact is accounted for in the rating
- More details can be found on the CTI website [www.cti.org](http://www.cti.org)

### Evapco Europe CTI Certified LPT Product Line

#### LPT Line of CTI Certified Cooling Towers

- CTI Certification Validation Number 05-13-03
- Includes Intake attenuators and related motor changes
- Includes Discharge attenuators and related motor changes
- Includes Full sound attenuators and related motor changes
- Includes motor size changes
- Includes Tapered discharge hoods
- **Spectrum™** Technical data sheet will state "ECC-CTI Certified Cooling Tower"
- Unit will receive a CTI and ECC Certified Shield located near the nameplate

#### Note

All CTI Certified Product Lines of all manufacturers with CTI certified products can be found on the website: <http://www.cti.org/certification.shtml>



† Mark owned by the Cooling Technology Institute

In 2007 Evapco launched the initiative to create the "European Chapter" of CTI. At the start of this initiative, Eurovent and CTI established a "Memorandum of Understanding". Since then the "Operational Manual for Certification of Cooling Towers" and the "Eurovent Rating Standard for Cooling Towers" were written. Both documents are strongly tied to the CTI documents STD 201 and ATC 105. A common "Eurovent-CTI" Certification program has become the European Standard for independent thermal performance rating of cooling towers. All Evapco CTI Certified cooling towers will be **Eurovent-CTI certified as from February 2012.**

### EUROVENT – CTI cooperation

#### EUROVENT Association

Initially founded in 1958 EUROVENT Association represents the European refrigeration, air conditioning, air handling, heating and ventilation industry and trade associations from European and non-European countries. Over 1000 companies in 13 European countries, employing 150000 employees who jointly generate more than €25 to 30 billion of annual output are member of this organization.



#### EUROVENT mission

EUROVENT represents, promotes and defends the industry to relevant national and international bodies and cooperates with other European umbrella associations. Over the years EUROVENT has become a well-known and respected stakeholder in all industry related matters and, in particular, in climate change and energy efficiency. EUROVENT develops product certification programs for the entire industry through the EUROVENT Certification Company.

#### EUROVENT Certification



The main objective of the EUROVENT Certification Company (ECC) is to certify cooling equipment (and/or components) independ-

ently from EUROVENT Association. With a common set of well-defined procedures and criteria for the rating of products, comparison of product performance ensures a healthy and solid competition on a market open to all manufacturers. When a manufacturer participates in a certification program, he has to present its list of models or model ranges together with their performance data. The files are evaluated by the ECC Certification and a predefined number of units are selected for testing by **independent laboratories**. If the results comply with the relevant standards, the submitted models or ranges will be listed in the **EUROVENT Certification Online Directory**. Models are subject to regular random testing to verify compliance with catalogue data.

#### Benefits

The Certification Mark guarantees specifying engineers, installers and end users that the products marketed by a participant have been submitted to independent testing and that they have been accurately rated. Through specification of **certified products**, the engineer's tasks become easier, since there is no need to carry out detailed comparison and performance testing.





# LPT

## Thermal Performance

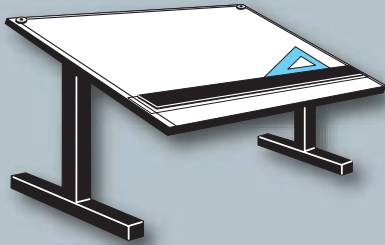

## Engineering Data & Dimensions

# LPT

# THERMAL PERFORMANCE

To Make a Selection:

Locate the column with the desired operating temperature conditions. Read down the column until you find the l/s equal to or greater than the flow required. Read horizontally to the left to find the model number of the unit that will perform the duty.

## Low Profile Cooling Towers

## Models LPT 316 to 8812

		Cooling Capacity in l/s																				
		TEMP C°																				
Model No.	Motor kW	EWT	32	36	32	36	32	36	32	37	35	40	35	40	35	37	40	42	36	37	41	42
		LWT	27	26	27	26	27	26	27	27	30	30	30	30	30	32	30	32	31	32	31	32
		WB	19	19	20	20	21	21	22	22	24	24	25	25	26	26	26	26	27	27	27	27
LPT 316	1,1		7,8	4,3	7,2	3,9	6,4	3,5	5,6	3,7	7,5	4,8	6,7	4,3	5,7	8,4	3,8	5,4	6,0	7,5	4,0	4,9
LPT 326	1,5		9,7	5,4	8,9	4,9	8,0	4,4	7,0	4,6	9,3	6,0	8,3	5,4	7,1	10,3	4,8	6,7	7,5	9,2	5,0	6,1
LPT 336	2,2		10,9	6,1	10,1	5,6	9,0	5,0	7,9	5,3	10,5	6,8	9,4	6,2	8,1	11,7	5,5	7,6	8,5	10,4	5,8	7,0
LPT 346	2,2		12,1	6,9	11,1	6,3	10,0	5,7	8,8	6,0	11,6	7,7	10,4	7,0	9,0	12,8	6,2	8,5	9,5	11,5	6,5	7,8
LPT 356	4,0		13,9	8,0	12,9	7,4	11,6	6,7	10,3	7,0	13,4	8,9	12,1	8,1	10,5	14,7	7,2	9,9	11,0	13,3	7,6	9,1
LPT 366	5,5		15,5	9,1	14,4	8,3	13,0	7,5	11,6	7,9	14,9	10,1	13,5	9,2	11,8	16,3	8,2	11,1	12,3	14,8	8,6	10,2
LPT 516	2,2		16,5	9,2	15,2	8,4	13,6	7,5	12,0	7,9	15,8	10,3	14,1	9,3	12,2	17,5	8,2	11,5	12,8	15,7	8,7	10,5
LPT 526	4,0		19,3	10,9	17,7	9,9	15,9	8,9	14,0	9,4	18,5	12,1	16,5	11,0	14,3	20,5	9,7	13,5	15,0	18,3	10,2	12,3
LPT 536	2,2		19,7	11,8	18,3	10,9	16,6	9,9	14,8	10,4	19,0	12,9	17,2	11,9	15,0	20,8	10,7	14,3	15,8	18,9	11,2	13,1
LPT 546	4,0		21,0	12,1	19,4	11,1	17,5	10,0	15,5	10,5	20,2	13,4	18,2	12,2	15,7	22,2	10,9	14,9	16,5	20,0	11,4	13,6
LPT 556	5,5		21,6	12,3	20,0	11,3	18,0	10,2	15,9	10,7	20,8	13,7	18,7	12,5	16,1	22,9	11,1	15,2	17,0	20,7	11,7	13,9
LPT 566	5,5		22,8	13,3	21,2	12,2	19,2	11,0	17,0	11,6	22,0	14,7	19,9	13,5	17,3	24,1	12,0	16,4	18,2	21,9	12,6	15,0
LPT 576	7,5		24,8	14,6	23,0	13,4	20,9	12,1	18,6	12,7	23,9	16,2	21,6	14,8	18,9	26,1	13,1	17,9	19,8	23,7	13,8	16,4
LPT 586	5,5		25,3	15,4	23,6	14,2	21,5	12,9	19,3	13,5	24,4	16,9	22,2	15,6	19,6	26,6	14,0	18,6	20,4	24,3	14,6	17,2
LPT 596	7,5		27,2	16,7	25,4	15,5	23,2	14,1	20,8	14,7	26,4	18,4	24,0	16,9	21,2	0,0	15,2	20,2	22,1	26,2	15,9	18,6
LPT 519	7,5		28,7	16,2	26,4	14,8	23,7	13,3	20,9	13,9	27,6	18,0	24,6	16,4	21,3	30,5	14,5	20,1	22,4	27,4	15,3	18,3
LPT 529	11,0		32,3	18,4	29,9	16,8	26,9	15,1	23,7	15,9	31,1	20,4	27,9	18,6	24,1	34,1	16,5	22,7	25,3	30,9	17,4	20,8
LPT 539	11,0		34,2	19,9	31,7	18,2	28,7	16,5	25,4	17,3	32,9	22,0	29,7	20,1	25,8	36,1	17,9	24,4	27,1	32,7	18,8	22,4
LPT 549	15,0		36,1	21,2	33,5	19,4	30,4	17,6	27,0	18,4	34,8	23,5	31,5	21,4	27,4	38,1	19,1	26,0	28,8	34,6	20,0	23,8
LPT 559	11,0		37,5	22,8	34,9	21,0	31,9	19,2	28,5	20,0	36,2	25,0	32,9	23,0	29,0	39,4	20,7	27,5	30,3	36,0	21,6	25,4
LPT 569	15,0		40,6	24,9	37,9	23,0	34,7	21,0	31,1	21,9	39,3	27,3	35,8	25,2	31,6	0,0	22,6	30,0	33,0	39,0	23,7	27,8
LPT 5112	11,0		38,3	21,9	35,3	20,1	31,8	18,2	28,0	19,0	36,8	24,3	33,0	22,1	28,5	40,5	19,7	27,0	30,0	36,5	20,7	24,7
LPT 5212	15,0		41,9	24,2	38,8	22,2	35,0	20,0	30,9	21,0	40,4	26,8	36,3	24,4	31,5	44,3	21,7	29,7	33,0	40,1	22,8	27,2
LPT 5312	18,5		44,9	26,1	41,6	23,9	37,7	21,6	33,3	22,7	43,3	28,9	39,0	26,4	33,9	47,4	23,5	32,1	35,6	43,0	24,7	29,4
LPT 5412	22,0		47,4	27,7	44,0	25,4	39,9	23,0	35,4	24,1	45,8	30,7	41,3	28,0	36,0	50,1	25,0	34,1	37,8	45,4	26,2	31,2
LPT 5512	18,5		47,7	28,9	44,5	26,7	40,5	24,3	36,2	25,4	46,1	31,7	41,9	29,2	36,8	50,3	26,2	34,9	38,5	45,8	27,4	32,2
LPT 5612	22,0		49,8	30,2	46,4	27,9	42,4	25,4	37,9	26,6	48,1	33,2	43,7	30,6	38,5	52,4	27,4	36,6	40,2	47,8	28,7	33,7
LPT 5712	22,0		52,6	32,6	49,1	30,3	44,9	27,7	40,3	28,9	50,9	35,6	46,3	32,9	40,9	55,4	29,8	39,0	42,7	50,5	31,1	36,2
LPT 819	15,0		51,0	29,1	47,2	26,6	42,5	23,9	37,4	25,2	49,2	32,3	44,1	29,4	38,0	54,0	26,1	35,9	40,0	48,8	27,5	32,8
LPT 829	11,0		52,7	30,5	48,8	28,0	44,2	25,3	39,0	26,6	50,8	33,9	45,8	30,9	39,7	55,7	27,5	37,6	41,7	50,4	28,9	34,4
LPT 839	15,0		54,1	31,4	50,2	28,9	45,4	26,1	40,2	27,3	52,1	34,8	47,0	31,8	40,9	57,1	28,3	38,7	42,9	51,7	29,8	35,4
LPT 849	11,0		55,8	33,7	51,9	31,1	47,3	28,3	42,2	29,6	53,9	37,0	48,9	34,0	42,9	58,8	30,6	40,8	44,9	53,5	32,0	37,6
LPT 859	18,5		57,3	33,6	53,2	30,8	48,3	27,8	42,8	29,2	55,3	37,2	49,9	34,0	43,5	60,4	30,2	41,2	45,7	54,9	31,8	37,8
LPT 869	22,0		58,9	34,7	54,8	31,9	49,8	28,8	44,2	30,2	56,9	38,4	51,5	35,1	45,0	62,2	31,3	42,6	47,1	56,5	32,9	39,1
LPT 879	18,5		61,5	37,5	57,4	34,7	52,4	31,6	46,9	33,0	59,5	41,2	54,1	37,9	47,6	64,8	34,1	45,3	49,8	59,0	35,7	41,8
LPT 8112	18,5		65,1	37,4	60,2	34,3	54,3	31,0	47,9	32,6	62,7	41,5	56,3	37,9	48,8	68,9	33,7	46,1	51,3	62,2	35,4	42,2
LPT 8212	22,0		70,1	40,6	64,9	37,2	58,7	33,7	51,9	35,3	67,6	45,0	60,8	41,1	52,8	74,1	36,5	50,0	55,5	67,1	38,4	45,7
LPT 8312	30,0		73,7	43,0	68,4	39,4	62,0	35,6	54,9	37,4	71,1	47,6	64,1	43,5	55,8	77,8	38,7	52,8	58,6	70,6	40,6	48,4
LPT 8412	22,0		74,1	44,7	69,0	41,3	62,9	37,6	56,1	39,3	71,6	49,2	64,9	45,2	57,0	78,1	40,6	54,1	59,6	71,1	42,5	49,9
LPT 8512	37,0		78,9	46,4	73,3	42,6	66,6	38,5	59,1	40,4	76,1	51,4	68,8	46,9	60,1	83,2	41,8	56,9	63,0	75,6	43,9	52,2
LPT 8612	30,0		80,8	49,2	75,4	45,4	68,8	41,4	61,6	43,3	78,2	54,0	71,0	49,7	62,5	85,1	44,7	59,4	65,4	77,6	46,7	54,9
LPT 8712	37,0		86,1	52,7	80,3	48,7	73,4	44,4	65,8	46,4	83,2	57,9	75,7	53,3	66,8	0,0	47,9	63,6	69,8	82,6	50,1	58,7
LPT 8812	37,0		88,4	54,9	82,5	51,0	75,5	46,7	67,8	48,7	85,5	60,0	77,8	55,5	68,8	0,0	50,2	65,6	71,8	84,9	52,4	60,9

Note: For alternate selections and conditions other than those stated, consult your iES selection program or local EVAPCO representative.

# ENGINEERING DATA AND DIMENSIONS

# LPT

\* DN 100 connections are Male Pipe Thread, DN 150 connections are both beveled for welding and grooved for a mechanical coupling. Consult the factory for special connection requirements.

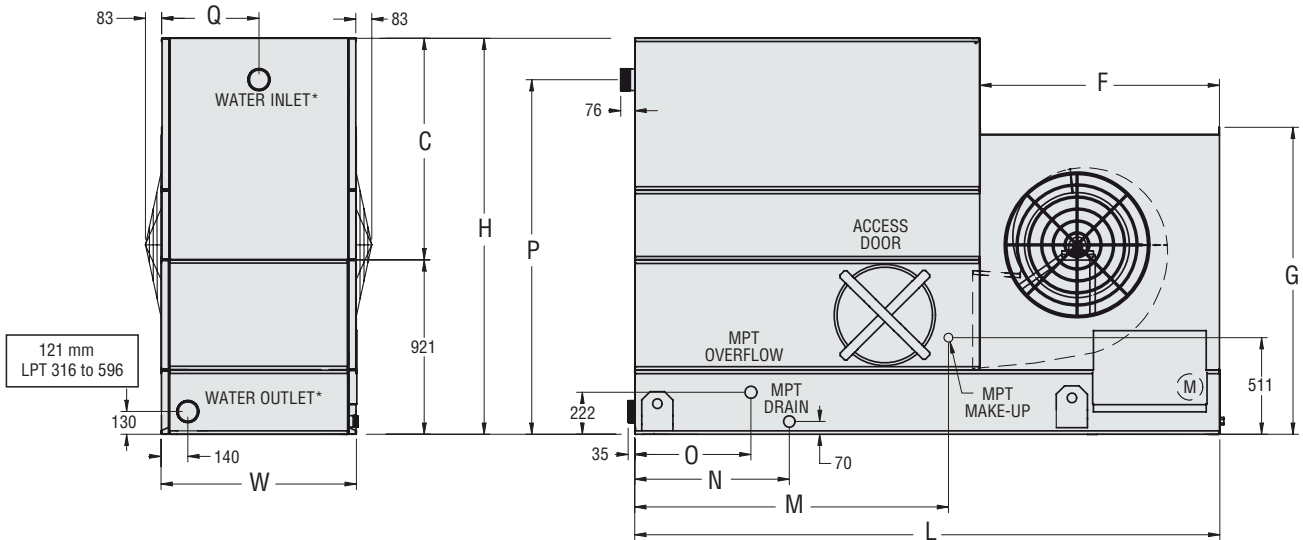

## Low Profile Cooling Towers

## Models LPT 316 to 5712

Model No.	Weight (kg)		No. Fans	Fan Motor kW**	Air Flow m³/s	Dimensions (mm)										Connections (mm)					
	Shipping	Operating				H	W	L	P	Q	C	O	N	M	F	G	Water In	Water Out	Make Up	Over Flow	
LPT 316	685	1130	1	1,1	3,3	2096	1029	3099	1876	514	1175	616	819	1676	1270	1622	100	100	25	50	50
LPT 326	690	1130	1	1,5	4,2	2096	1029	3099	1876	514	1175	616	819	1676	1270	1622	100	100	25	50	50
LPT 336	695	1140	1	2,2	4,8	2096	1029	3099	1876	514	1175	616	819	1676	1270	1622	100	100	25	50	50
LPT 346	735	1175	1	2,2	4,7	2096	1029	3099	1876	514	1175	616	819	1676	1270	1622	100	100	25	50	50
LPT 356	740	1180	1	4,0	5,6	2096	1029	3099	1876	514	1175	616	819	1676	1270	1622	100	100	25	50	50
LPT 366	755	1195	1	5,5	6,4	2096	1029	3099	1876	514	1175	616	819	1676	1270	1622	100	100	25	50	50
LPT 516	1050	1835	1	2,2	7,0	2099	1540	3734	1873	772	1178	616	857	1676	1905	2026	100	100	25	50	80
LPT 526	1055	1835	1	4,0	8,3	2099	1540	3734	1873	772	1178	616	857	1676	1905	2026	100	100	25	50	80
LPT 536	1120	1900	1	2,2	6,9	2403	1540	3734	2178	772	1483	616	857	1676	1905	2026	100	100	25	50	80
LPT 546	1095	1875	1	4,0	8,2	2099	1540	3734	1873	772	1178	616	857	1676	1905	2026	100	100	25	50	80
LPT 556	1075	1860	1	5,5	9,5	2099	1540	3734	1873	772	1178	616	857	1676	1905	2026	100	100	25	50	80
LPT 566	1090	1870	1	5,5	9,4	2099	1540	3734	1873	772	1178	616	857	1676	1905	2026	100	100	25	50	80
LPT 576	1125	1910	1	7,5	10,1	2099	1540	3734	1873	772	1178	616	857	1676	1905	2026	100	100	25	50	80
LPT 586	1145	1925	1	5,5	9,3	2403	1540	3734	2178	772	1483	616	857	1676	1905	2026	100	100	25	50	80
LPT 596	1160	1940	1	7,5	10,1	2403	1540	3734	2178	772	1483	616	857	1676	1905	2026	100	100	25	50	80
LPT 519	1280	2465	1	7,5	12,5	2149	1540	4632	1902	772	1229	1514	1705	2575	1905	2026	150	150	25	50	80
LPT 529	1330	2510	1	11,0	14,3	2149	1540	4632	1902	772	1229	1514	1705	2575	1905	2026	150	150	25	50	80
LPT 539	1355	2535	1	11,0	14,1	2149	1540	4632	1902	772	1229	1514	1705	2575	1905	2026	150	150	25	50	80
LPT 549	1360	2540	1	15,0	15,2	2149	1540	4632	1902	772	1229	1514	1705	2575	1905	2026	150	150	25	50	80
LPT 559	1440	2615	1	11,0	14,0	2454	1540	4632	2207	772	1534	1514	1705	2575	1905	2026	150	150	25	50	80
LPT 569	1470	2645	1	15,0	15,2	2454	1540	4632	2207	772	1534	1514	1705	2575	1905	2026	150	150	25	50	80
LPT 5112	1560	3170	1	11,0	15,2	2149	1540	5556	1902	772	1229	2438	2629	3499	1905	2026	150	150	25	50	80
LPT 5212	1565	3180	1	15,0	16,7	2149	1540	5556	1902	772	1229	2438	2629	3499	1905	2026	150	150	25	50	80
LPT 5312	1570	3185	1	18,5	18,0	2149	1540	5556	1902	772	1229	2438	2629	3499	1905	2026	150	150	25	50	80
LPT 5412	1585	3195	1	22,0	19,1	2149	1540	5556	1902	772	1229	2438	2629	3499	1905	2026	150	150	25	50	80
LPT 5512	1680	3290	1	18,5	17,9	2454	1540	5556	2207	772	1534	2438	2629	3499	1905	2026	150	150	25	50	80
LPT 5612	1685	3300	1	22,0	19,0	2454	1540	5556	2207	772	1534	2438	2629	3499	1905	2026	150	150	25	50	80
LPT 5712	1805	3410	1	22,0	18,9	2759	1540	5556	2511	772	1838	2438	2629	3499	1905	2026	150	150	25	50	80

Notes:

- 1) An adequately sized bleed line must be installed in the cooling tower system to prevent buildup of impurities in the recirculated water.
- 2) Do not use catalog drawings for certified prints. Dimensions subject to change.
- 3) For external static pressure up to 120 Pa, use next size fan motor.

\*\* One fan motor per unit.





## SPECIFICATIONS

### 1.0 FORCED DRAFT LPT COOLING TOWER

#### 1.1 General

Furnish and install factory assembled cooling tower of blow through, counterflow design with a horizontal single air side entry and a vertical air discharge. The unit shall be completely factory assembled and be conform to the specifications and schedules.

The total fan power should not exceed \_\_\_\_ kW and the total overall unit dimensions should not exceed the following:

Length: mm  
Width: mm  
Height: mm

The unit will be delivered in one part.

Approved manufacturer: Evapco – model LPT \_\_\_\_\_

#### 1.2 Thermal Performance – Performance Warranty

The tower shall be capable of performing the thermal duties as shown in the schedule and on the drawings, and its design thermal rating shall be certified by the Cooling Technology Institute (C.T.I.) and the Eurovent Certification Company (ECC). Only models with performance certified by CTI and ECC will be approved.

Manufacturers' performance guarantee without ECC-CTI certification for the proposed model or an independent field performance test shall not be accepted.

#### 1.3 Applicable Standards

- ATC 128 Test Code for Measurement of Sound from Water Cooling Towers
- CTI STD 201 Standard for Thermal Performance Certification of Evaporative Heat Rejection Equipment
- Eurovent Rating Standard for Cooling Towers

#### 1.4 Submittals

- The manufacturer shall submit a five year history of the proposed type of cooling tower with a minimum of 10 installations for similar sized equipment.
- Shop drawings: submit shop drawings indicating dimensions, weight loadings and required clearances.
- Product data: submit manufacturer's technical product data, original selection printouts and clearance requirements.
- Performance data: submit curves showing certified and guaranteed cooling tower performance with variation in outdoor air wet bulb temperature at design air flow and design flow rate.  
In addition submit performance curves for 90% and 110% of design water flow rate, indicating the cooling tower temperatures versus the ambient air wet bulb temperatures.
- Complete noise data sheet for the selected cooling tower.
- Maintenance data for the cooling tower and accessories.
- The cooling tower manufacturer shall provide factory test run certificates of the fans and fan motor.

#### 1.5 Product Delivery – Storage and Handling

- The contractor shall make the provisions for proper storage at site before installation and handle the product per the instructions of the manufacturer.
- Once installed provide the necessary measures that the units remain clean and protected from any dust and mechanical damage.

#### 1.6 Quality Assurance

- The manufacturer shall have a quality assurance system in place which is certified by an accredited registrar and complying with the requirements of ISO 9001:2008. This is to guarantee a consistent level of product and service quality.
- Manufacturers without ISO 9001:2008 certification are not acceptable.

#### 1.7 Warranty

- The products will be warranted for two years from the date of shipment.

### 2.0 PRODUCT

#### 2.1 Construction – Corrosion Resistance

##### STANDARD EXECUTION – GALVANIZED STEEL Z-725

- The structure and all steel elements of the pan and casing shall be constructed of Z-725 hot dip galvanized steel for long life and durability. Alternatives with lower zinc layer thickness and external paint or coating are not accepted as equal.
- The strainer shall be made of stainless steel type 304L.
- During fabrication all panel edges shall be coated with a 95% pure zinc compound.
- Casing materials shall be of non flammable construction.

##### OPTIONAL EXECUTION – BASIN IN SST 304L

- The structure and all steel elements of the Basin and Louver section up to the water level shall be made of SST 304L.
- Alternatives with hot dip galvanized steel and epoxy coatings in lieu of the SST 304L are not considered to be equal and are not accepted.
- All other steel components of the casing shall be constructed of Z-725 hot dip galvanized steel for long life and durability. Alternatives with lower zinc layer thickness and external paint or coating are not accepted as equal.
- The strainer shall be made of stainless steel type 304L.
- During fabrication all galvanized steel panel edges shall be coated with a 95% pure zinc compound.
- Casing materials shall be of non flammable construction.

##### UAT EXECUTION – Complete Unit SST 304L (except moving parts)

- The structure and all steel elements shall be made of SST 304L.
- Alternatives with hot dip galvanized steel and epoxy coatings in lieu of the SST 304L are not considered equal and accepted.
- Casing materials shall be of non flammable construction.

#### 2.2 Construction – Seismic and wind load resistance

- The structural design must withstand 1g seismic or 2.87 kN/m<sup>2</sup> wind loads.
- Cooling Towers must be independently certified according to IBC.

#### 2.3 Pan / Fan section

- The pan – fan section shall include fans and drives mounted and aligned in the factory. These items shall be located in the dry air stream.
- Standard pan accessories shall included circular access doors, strainer(s) of anti vortex design, brass make up valve with unsinkable, foam filled plastic float arranged for easy adjustment.
- The basin bottom shall be sloped to provide drainage of the complete basin section.

#### 2.4 Mechanical Equipment

##### 2.4.1 Fan(s)

- Fans shall be dynamically balanced forwardly curved centrifugal type fans.
- Fan housings shall have curved inlet rings for efficient air entry and rectangular discharge cowls which extend into the basin to increase fan efficiency and to prevent water from splashing into the fans.
- Curved inlet rings shall be made of the same material as the cooling tower.
- All fans will undergo a dry running test in the factory after being installed in the cooling tower basin.

# LPT

## SPECIFICATIONS

- e) The fans will be mounted on either a solid or a hollow shaft with forged bearing journals.
- f) Easy to remove fan screens shall be provided to avoid direct contact with the moving parts.

### 2.4.2 Bearings and Drive

- a) The fan shaft(s) shall be supported by heavy duty, self aligning pillow block bearings with cast iron housings and lubrication fittings for maintenance.
- b) The fan drives shall be V belt type with taper lock sheaves designed for 150% of the motor nameplate horsepower.
- c) The bearings shall be rated for an L-10 life of 75,000 to 135,000 hours.

### 2.4.3 Motor

- a) The fan motor shall be Totally Enclosed, Fan Cooled (TEFC), squirrel cage, ball bearing type motor.
- b) The motor shall be minimum IP 55 degree of protection, Class F insulation, Service Factor 1 and selected for the appropriate cooling tower duty and the correct ambient temperature but minimum 40°C.
- c) Motor bearings shall be greased for life or external grease lines shall be provided.
- d) The motor shall be mounted on an adjustable heavy duty steel motor base.
- e) The motor selection shall be selected for the appropriate external static pressure.
- f) The motor power supply shall be \_\_\_\_ volts, \_\_\_\_ Hertz and \_\_\_\_ Phase.

## 2.5. Casing Section

### 2.5.1 Heat Transfer

- a) The cooling tower fill shall be PVC (Polyvinyl Chloride) of cross fluted design for optimum heat transfer and efficiency.
- b) The cross fluted sheets shall be bonded together for maximum strength and durability. Fill packs which are not bonded are not allowed.
- c) The PVC fill shall be self extinguishing for fire resistance with a flame spread rating less than 25 under ASTM-E84.
- d) The fill shall be resistant to rot, decay or biological attack.
- e) The fill shall be able to withstand a water temperature of 55°C. The fill sheets will be bonded together in such a way that the structural integrity of the fill makes the fill useable as a working platform.
- f) The cooling tower manufacturer shall be responsible for the manufacturing and performance testing of the fill. This is to assure single source responsibility.

### 2.5.2 Water Distribution

- a) The spray header and branches shall be constructed of Schedule 40, Polyvinyl Chloride (PVC) pipe for corrosion resistance and shall have a steel connection to attach the external piping.
- b) The internal tower water distribution piping shall be easily removable for cleaning purposes.
- c) The water shall be distributed over the fill by precision molded ABS spray nozzles with large minimum 25 mm orifice openings and integral sludge ring to eliminate clogging.
- d) The nozzles shall be threaded into the water distribution piping to assure positive positioning.
- e) Each cell shall have only one hot water return inlet, otherwise the cooling tower manufacturer shall provide the necessary extra provisions (piping, balancing valves, ...) to achieve the same at no extra cost.

### 2.5.3 Drift Eliminators

- a) The drift eliminators shall be constructed entirely inert polyvinyl (PVC) that has been specially treated to resist ultra violet light.
- b) Assembled in easily handled sections, the eliminator blades shall be spaced on 25 mm centers and shall incorporate three changes in air direction to assure efficient removal of entrained moisture from the discharge air stream.

- c) The maximum drift rate shall not exceed 0,001% of the recirculated water rate.

## 2.6 Sound Levels

The maximum sound pressure levels (dB) measured 15m from the cooling tower operating at full fan speed shall not exceed the sound levels detailed below.

Location	63Hz	125Hz	250Hz	500Hz	1000Hz	2000Hz	4000Hz	8000Hz	dB(A)
Discharge									
Air inlet									

## 3.0 ACCESSORIES (optional)

### 3.1 Electric Heaters

- a) The cooling tower cold water basin shall be provided with a electric heater package to prevent freezing of the water in the cold water basin.
- b) The electric heater package includes: electric heater elements and a combination of thermostat and low water level cutoff.
- c) The heaters shall be selected to maintain 4°C basin water temperature at \_\_\_\_°C ambient
- d) The heater(s) shall be \_\_\_\_V / \_\_\_\_ phase / \_\_\_\_ Hz electric power supply.

### 3.2 Three Probe Electric Water Level Control Package

- a) The cooling tower manufacturer shall provide an electric water level control package instead of the mechanical float valve arrangement.
- b) The package consist of the following elements:
  - Multiple heavy duty stainless steel SST 316 static probes mounted in a stilling tube outside the unit. Electrodes or sensors mounted inside the unit are not accepted as there operation will disturbed by the moving water in the basin.
  - A ABS, IP 56 case contains all the contactors for the different level probes and will provide a output signal of a relay for automatic filling and one relay for alarm level.
  - The power supply to the control package is 24 Vac / 230 Vac - \_\_\_\_ Hz .
  - A weather protected solenoid valve for the water make up ready for Piping to a water supply with pressure between 140 kPa and 340 kPa.

### 3.3 Intake Sound Attenuation

- a) The unit will be equipped with intake sound attenuation consisting of a hot dip galvanized steel housing of the same quality of the unit and completed with acoustical baffles made of fiberglass material which is suitable for use in cooling towers.
- b) The intake sound attenuator is provided with large access doors which allow access to maintain the fans and bearings.
- c) The cooling tower motor size must be adjusted for the additional static pressure drop caused by the sound attenuator.

### 3.4 Discharge Sound Attenuation

- a) The unit will be equipped with discharge sound attenuation consisting of a hot dip galvanized steel housing of the same quality of the unit and completed with acoustical baffles made of fiberglass material which is suitable for use in cooling towers.
- b) The discharge sound attenuator is provided with large access doors which allow access to maintain the water distribution system and the drift eliminators without removing the baffles.
- c) The cooling tower motor size must be adjusted for the additional static pressure drop caused by the sound attenuator.

### 3.5 Vibration Switch

- a) A vibration limit switch shall be installed on the mechanical equipment support and wired into the control panel.

## SPECIFICATIONS

# LPT

The purpose of this switch will be to interrupt power the motor in the event of excessive vibration.

- b) The switch shall be adjustable for sensitivity, and shall require manual reset.



# EVAPCO PRODUCTS ARE MANUFACTURED WORLDWIDE



- World Headquarters/ Research and Development Center
- EVAPCO Facilities

## EVAPCO, Inc. — World Headquarters & Research/Development Center

P.O. Box 1300 • Westminster, MD 21158 USA  
410.756.2600 • [marketing@evapco.com](mailto:marketing@evapco.com) • [evapco.com](http://evapco.com)

### North America

- EVAPCO, Inc. World Headquarters**  
Westminster, MD USA  
410.756.2600  
[marketing@evapco.com](mailto:marketing@evapco.com)
- EVAPCO East**  
Taneytown, MD USA
- EVAPCO East**  
Key Building  
Taneytown, MD USA
- EVAPCO Midwest**  
Greenup, IL USA  
217.923.3431  
[evapcomw@evapcomw.com](mailto:evapcomw@evapcomw.com)
- Evapcold Manufacturing**  
Greenup, IL USA
- EVAPCO Newton**  
Newton, IL USA  
618.783.3433  
[evapcomw@evapcomw.com](mailto:evapcomw@evapcomw.com)
- EVAPCO West**  
Madera, CA USA  
559.673.2207  
[contact@evapcowest.com](mailto:contact@evapcowest.com)
- EVAPCO Alcoil, Inc.**  
York, PA USA  
717.347.7500  
[info@evapco-alcoil.com](mailto:info@evapco-alcoil.com)
- EVAPCO Iowa**  
Lake View, IA USA
- EVAPCO Iowa**  
Sales & Engineering  
Medford, MN USA  
507.446.8005  
[evapcomn@evapcomn.com](mailto:evapcomn@evapcomn.com)
- EVAPCO LMP ULC**  
Laval, Quebec, Canada  
450.629.9864  
[info@evapcolmp.ca](mailto:info@evapcolmp.ca)
- EVAPCO Select Technologies, Inc.**  
Belmont, MI USA  
844.785.9506  
[emarketing@evapcoselect.com](mailto:emarketing@evapcoselect.com)
- Refrigeration Vessels & Systems Corporation**  
Bryan, TX USA  
979.778.0095  
[rvs@rvscorp.com](mailto:rvs@rvscorp.com)
- Tower Components, Inc.**  
Ramseur, NC USA  
336.824.2102  
[mail@towercomponentsinc.com](mailto:mail@towercomponentsinc.com)
- EvapTech, Inc.**  
Edwardsville, KS USA  
913.322.5165  
[marketing@evaptech.com](mailto:marketing@evaptech.com)
- EVAPCO Dry Cooling, Inc.**  
Bridgewater, NJ USA  
908.379.2665  
[info@evapcodc.com](mailto:info@evapcodc.com)
- EVAPCO Dry Cooling, Inc.**  
Littleton, CO USA  
908.895.3236  
[info@evapcodc.com](mailto:info@evapcodc.com)
- EVAPCO Power México S. de R.L. de C.V.**  
Mexico City, Mexico  
(52) 55.8421.9260  
[info@evapcodc.com](mailto:info@evapcodc.com)

### Asia / Pacific

- EVAPCO Asia Pacific Headquarters**  
Baoshan Industrial Zone Shanghai, P.R. China  
(86) 21.6687.7786  
[marketing@evapcochina.com](mailto:marketing@evapcochina.com)
- EVAPCO (Shanghai) Refrigeration Equipment Co., Ltd.**  
Baoshan Industrial Zone, Shanghai, P.R. China
- EVAPCO (Beijing) Refrigeration Equipment Co., Ltd.**  
Huairou District, Beijing, P.R. China  
(86) 10.6166.7238  
[marketing@evapcochina.com](mailto:marketing@evapcochina.com)
- (Jiaxing) Company, Ltd.**  
Jiaxing, Zhejiang, P.R. China  
(86) 573.8311.9379  
[info@evapcochina.com](mailto:info@evapcochina.com)
- EVAPCO Australia (Pty.) Ltd.**  
Riverstone, NSW, Australia  
(61) 02.9627.3322  
[sales@evapco.com.au](mailto:sales@evapco.com.au)
- EvapTech (Shanghai) Cooling Tower Co., Ltd**  
Baoshan District, Shanghai, P.R. China  
Tel: (86) 21.6478.0265
- EvapTech Asia Pacific Sdn. Bhd.**  
Puchong, Selangor, Malaysia  
(60) 3.8070.7255  
[marketing-ap@evaptech.com](mailto:marketing-ap@evaptech.com)

### Europe | Middle East | Africa

- EVAPCO Europe EMENA Headquarters**  
Tongeren, Belgium  
(32) 12.39.50.29  
[info@evapco.be](mailto:info@evapco.be)
- EVAPCO Europe BV**  
Tongeren, Belgium
- EVAPCO Europe, S.r.l.**  
Milan, Italy  
(39) 02.939.9041  
[evapcoeuropa@evapco.it](mailto:evapcoeuropa@evapco.it)
- EVAPCO Europe, S.r.l.**  
Sondrio, Italy
- EVAPCO Europe A/S**  
Aabybro, Denmark  
(45) 9824.4999  
[info@evapco.dk](mailto:info@evapco.dk)
- EVAPCO Europe GmbH**  
Meerbusch, Germany  
(49) 2159.69560  
[info@evapco.de](mailto:info@evapco.de)
- EVAPCO Middle East DMCC**  
Dubai, United Arab Emirates  
(971) 56.991.6584  
[info@evapco.ae](mailto:info@evapco.ae)
- Evap Egypt Engineering Industries Co.**  
*A licensed manufacturer of EVAPCO, Inc.*  
Nasr City, Cairo, Egypt  
(20) 10.054.32.198  
[evapco@tiba-group.com](mailto:evapco@tiba-group.com)
- EVAPCO S.A. (Pty.) Ltd.**  
*A licensed manufacturer of EVAPCO, Inc.*  
Isando, South Africa  
(27) 11.392.6630  
[evapco@evapco.co.za](mailto:evapco@evapco.co.za)

### South America

- EVAPCO Brasil**  
*Equipamentos Industriais Ltda.*  
Indaiatuba, São Paulo, Brazil  
(55) 11.5681.2000  
[vendas@evapco.com.br](mailto:vendas@evapco.com.br)
- FanTR Technology Resources**  
Itu, São Paulo, Brazil  
(55) 11.4025.1670  
[fantr@fantr.com](mailto:fantr@fantr.com)