

Rigging & Assembly Instructions

ESW4

CLOSED CIRCUIT
COOLERS



Mr. GoodTower®

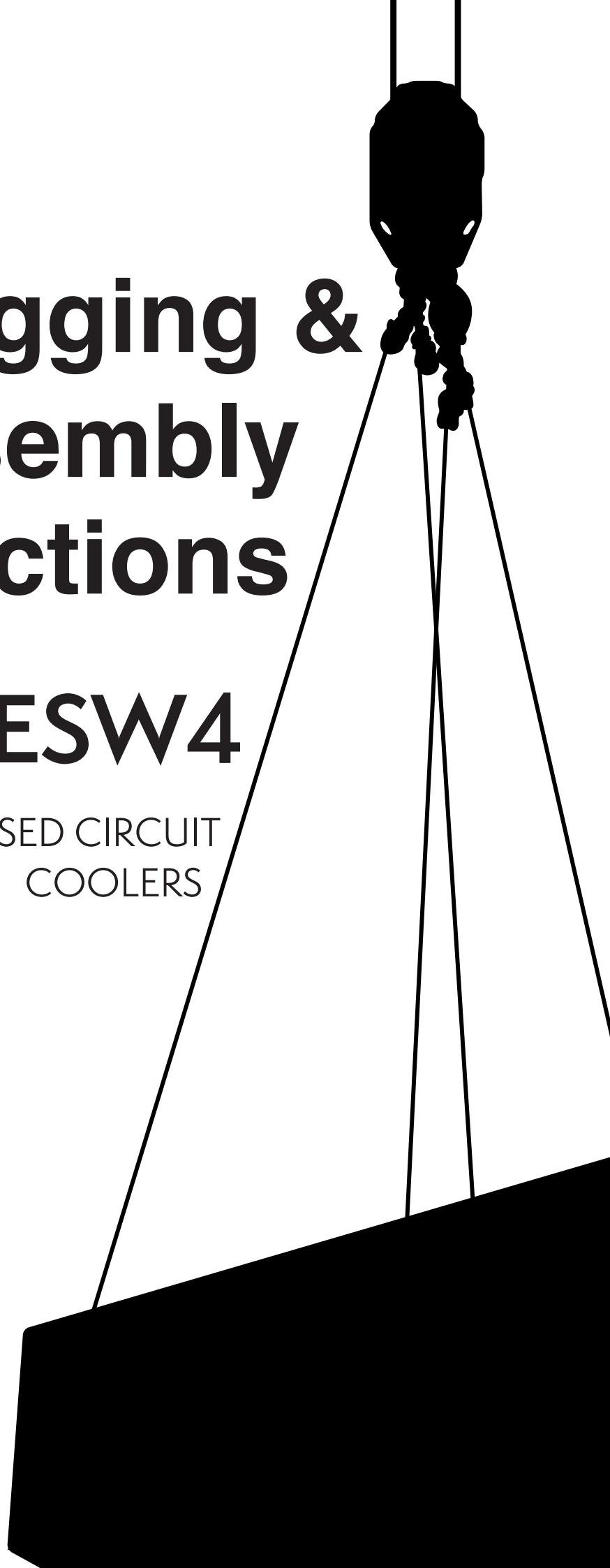



Method of Shipment

ESW4 models are shipped with the top section(s) separate from the bottom section(s). These sections have mating flanges and will join together in a waterproof joint when sealed and bolted together as described in the following instructions. Miscellaneous items, such as sealer tape, hardware and any other required materials, are packaged and placed inside the pan for shipment.

NOTE

All stainless steel rigging bolts should be coated with anti-seize spray on the threads to prevent nut galling.

Storage

Do not place tarps or other coverings over the top of the units if the units are to be stored before installation. Excessive heat can build up if the units are covered, causing possible damage to the PVC eliminators, louvers or fill. For extended storage beyond six months rotate the fan and fan motor shaft(s) monthly. Also, the fan shaft bearings should be purged and regreased prior to start-up.

International Building Code Provisions

The International Building Code (IBC) is a comprehensive set of regulations addressing the structural design and installation requirements for building systems – including HVAC and industrial refrigeration equipment. As of June 2008, all 50 states plus Washington D.C have adopted the International Building Code. The code provisions require that evaporative cooling equipment and all other components permanently installed on a structure must meet the same seismic design criteria as the building.

All items attached to the Evapco ESW4 Closed Circuit Cooler must be independently reviewed and isolated to meet applicable wind and seismic loads. This includes piping, ductwork, conduit, and electrical connections. These items must be flexibly attached to the Evapco unit so as not to transmit additional loads to the equipment as a result of seismic or wind forces.

Structural Steel Support

Evapco recommends supporting the unit with two structural “I” beams that span the entire length of the unit*. These beams should be located underneath the outer flanges of the unit. (See Figure 1). Mounting holes, 3/4” (19 mm) in diameter, are located in the bottom flange for bolting to the structural steel (see certified print for exact bolt hole location). Bolt the bottom section to the steel support before rigging the top section.

Beams should be sized in accordance with accepted structural practices. Maximum deflection of the beam under the unit not to exceed 1/2” (13 mm). Deflection may be calculated by using 55% of the operating weight as a uniform load on each beam (see certified print for operating weight).

The supporting “I” beams should be level before setting the unit. Do not level the unit by shimming between the bottom flange and the beams as this will not provide proper longitudinal support.

Support beams and anchor bolts are to be furnished by others. Always refer to certified print for unit weights, dimensions and technical data.

Note: Consult IBC for required steel support layout and structural design.

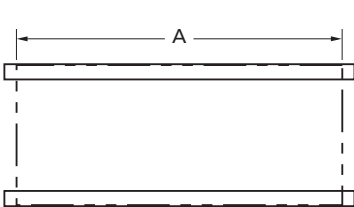

Figure 1A
Plan Views

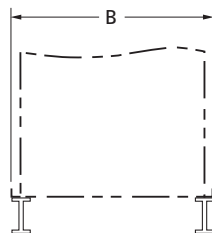

Figure 1B
End Elevations

Unit Footprint	A	B
8.5' x 6' (2,6 x 1,8 m)	8' 5-1/2" (2578 mm)	5' 11-7/8" (1826 mm)
8.5' x 9' (2,6 x 2,7 m)	8' 11-1/2" (2731 mm)	8' 5-1/2" (2578 mm)
8.5' x 12' (2,6 x 3,6 m)	11' 11-3/4" (3651 mm)	8' 5-1/2" (2578 mm)
8.5' x 18' (2,6 x 5,5 m)	18' 0" (5486 mm)	8' 5-1/2" (2578 mm)
12' x 12' (3,6 x 3,6 m)	11' 11-3/4" (3651 mm)	11' 10" (3607 mm)
12' x 18' (3,6 x 5,5 m)	18' 0" (5486 mm)	11' 10" (3607 mm)
14' x 22' (4,3 x 6,7 m)	21' 11-3/4" (6700 mm)	13' 11-1/4" (4250 mm)

Table 1 – ESW4 Supporting Steel Dimensions

* The Engineer of Record is ultimately responsible for the steel support design and may require additional cross beams based on loads.

Rigging the Bottom Section: Standard Lift

Lifting devices are located in the lower corners of the unit as shown in Figure 2 and 3. The hook of the crane must be a minimum dimension of “H” above the lift point to prevent undue strain on the lifting devices.

See Table 2 for the minimum “H” dimension. Bolt the bottom section to the steel support before rigging the top section of the unit.

The unit lifting devices should not be used for extended lifts or where any hazard exists unless safety slings are employed under the section.

Basin Section Length	Min. “H” Dim. (above lift point)
8.5’ (2,6 m)	7’ (2,1 m)
9’ (2,7 m)	7’ (2,1 m)
12’ (3,6 m)	10’ (3 m)
18’ (5,5 m)	12’ (3,6 m)
22’ (6,7 m)	21’ (6,4 m)

Table 2 – Minimum “H” Dimension for Basin Sections

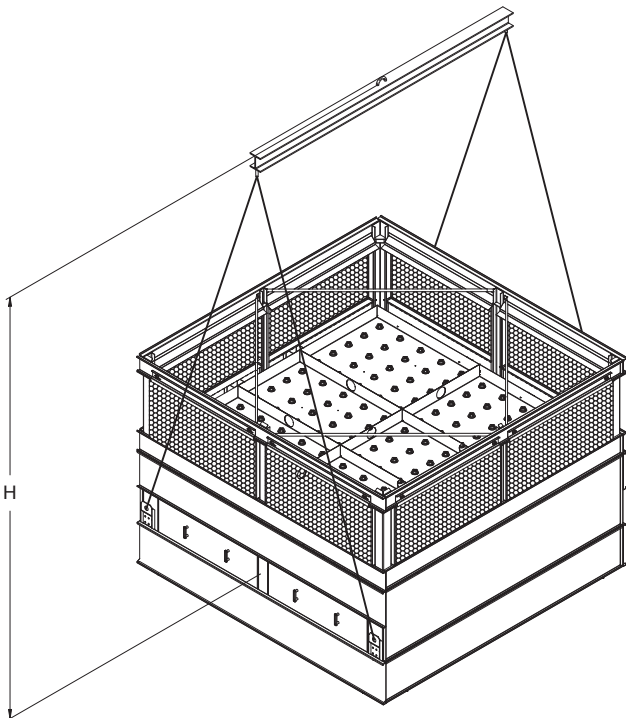

Figure 2 – ESW4 Bottom Section 4 point rig.

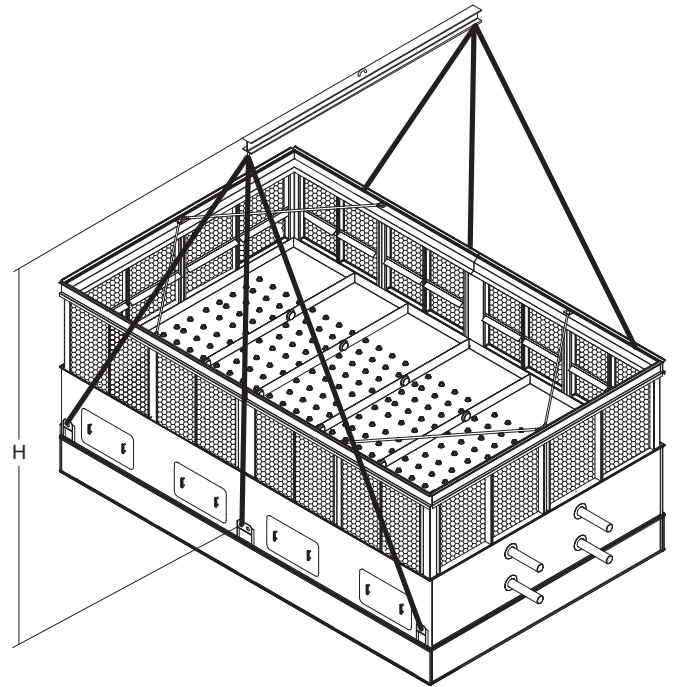

Figure 3 – ESW4 Bottom Section 18’ (5,5 m) and 22’ (6,7 m) 6 point rig

Important: The lifting devices should be used only for lifting where no danger exists and for final positioning of the section. For extended lifts, safety slings should be provided under the section as described on page 4.

Rigging the Bottom Section: Extended Lifts

The preferred method for extended lifts is to use slings under the unit as shown in Figure 4 and 5. Spreader bars should always be used between the cables at the top of the section to prevent damage to the upper portion of the basin. Safety slings and skids should be removed before final positioning of the unit. See Table 2 on page 3 for minimum “H” dimensions.

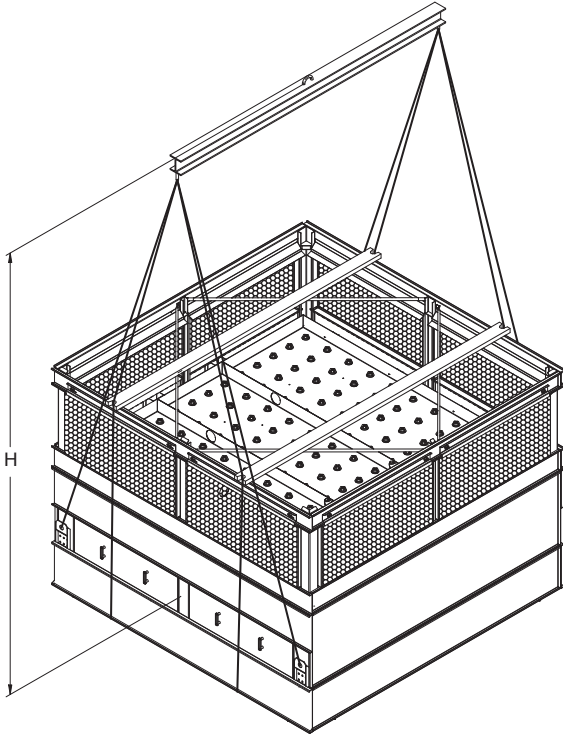

Figure 4 – Proper Rigging Method for Extended Lifts

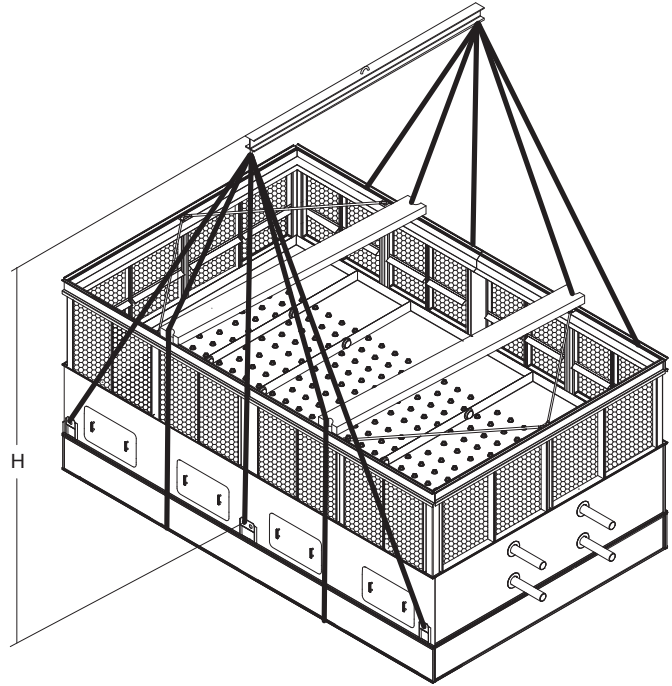

Figure 5 – Proper Rigging Method for Extended Lifts
18' (5,5 m) and 22' (6,7 m) long

Application of Sealer Tape

Once the bottom section has been set on the supporting steel and bolted in place, the top flanges should be wiped down to remove any dirt or moisture. Sealer tape should be placed over the mounting hole centerline on the side flanges along the entire length of all sides. Apply two strips of sealer tape, one partially overlapping the other, on the entire length of the end flanges.

The sealer tape should overlap on the corners as shown in Figure 6. Do not splice the sealer tape along the end flanges and preferably not on the side flanges if it can be avoided.

Always remove the paper backing from the sealer tape.

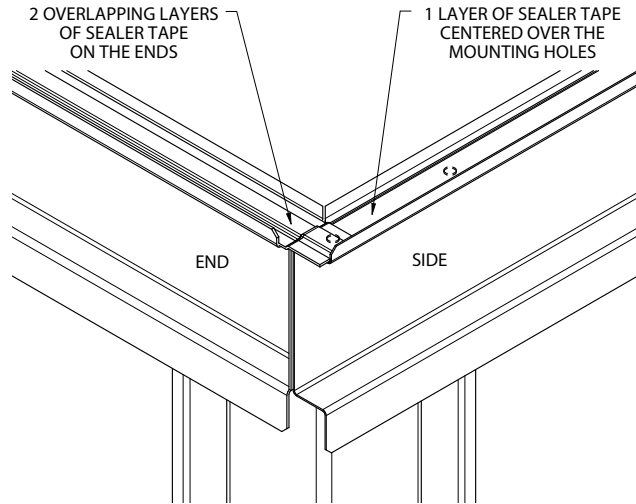

Figure 6 – Sealer Tape on Flange of Bottom Section

Rigging the Top Section: Standard Lift (2-Piece Shipment)

“U” bolts are provided in the four corners of the top section for lifting and final positioning (See Figure7). The hook of the crane must be a minimum dimension “H” above the top of the section being lifted to prevent undue strain on the “U” bolts. See Table 3 for the minimum “H” dimension.

Box Size	Minimum distance “H” from the fan (m)	
	Standard Fan	Super Low Sound Fan
8.5' x 6' (2.6 x 1,8 m)	7' (2,1 m)	8' (2,4 m)
8.5' x 9' (2.6 x 2,7 m)	9' (2,7 m)	12' (3,6 m)
8.5' x 12' (2.6 x 3,6 m)	12' (3,6 m)	12' (3,6 m)
8.5' x 18' (2.6 x 5,5 m)	17' (5,2 m)	20' (6 m)
12' x 12' (3.6 x 3,6 m)	12' (3,6 m)	15' (4,6 m)
12' x 18' (3.6 x 5,5 m)	17' (5,2 m)	19' (5,8 m)
14' x 22' (4,3 x 6,7 m)	18' (5,5 m)	18' (5,5 m)

Table 3 – Minimum “H” Dimension for Top Sections

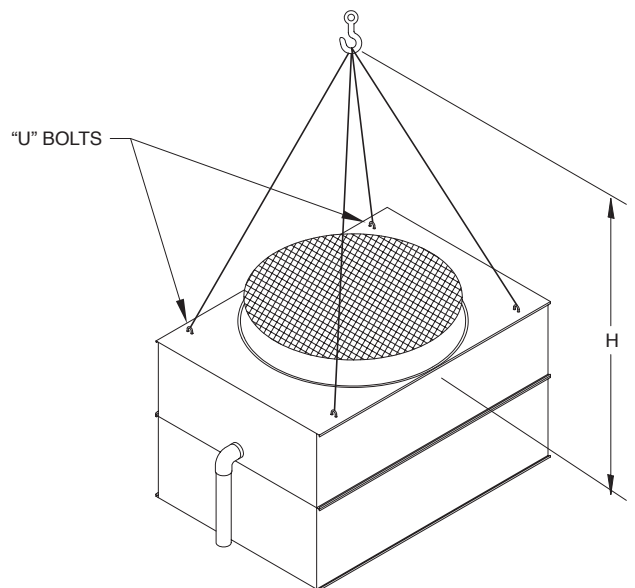

Figure 7 – ESW4 Top Section

Important: The “U” Bolts should be used only for lifting where no danger exists and for final positioning of the section. For extended lifts, safety slings should be provided under the section as described on page 6.

Rigging the Top Section: Extended Lifts

The preferred method for extended lifts is to use slings under the unit as shown in Figure 8. Spreader bars should always be used between the cables at the top of the section to prevent damage to the upper flanges or fan cylinder. Safety slings and skids should be removed before final positioning of the unit. See Table 3 on page 5 for minimum "H" dimensions.

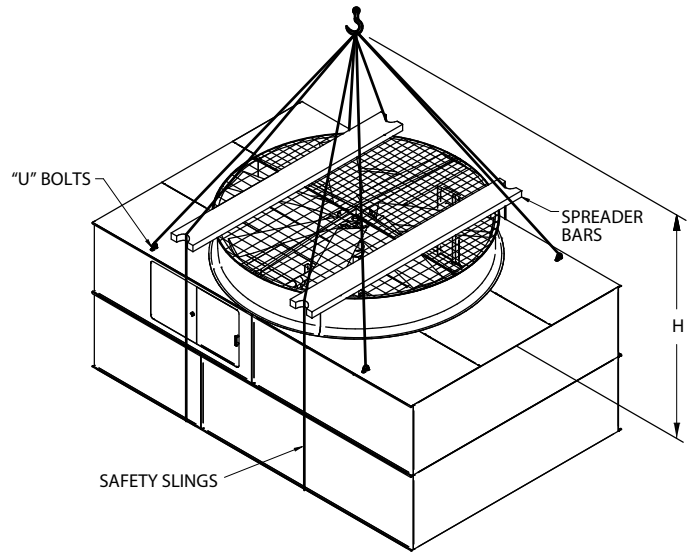

Figure 8 – Proper Rigging Method for Extended Lifts

Assembly of the Top Section to the Bottom Section

Before assembling the top section to the bottom section, remove any loose parts shipped in the pan. Apply sealer tape as shown in Figure 6 on page 5.

Wipe the flanges on the bottom of the top section. Check to see that the water distribution connection on the top section is in the correct position relative to the bottom section (see certified unit drawing). Units are also provided with match markings on each section (i.e. A1 of bottom section should match up with A1 of top section).

Lower the top section to within several inches of the bottom section making sure the two sections do not touch and the sealer tape is not disturbed. Using suitably sized drift pins to assure proper alignment, lower the top section down onto the bottom section.

Place nuts and bolts in all four corner bolt holes. Then continue to install the rest of the nuts and bolts working from the corners toward the center. Nuts and bolts must be installed in every hole on the side flanges and end flanges. Cut off extra sealer tape once the section is bolted into place.

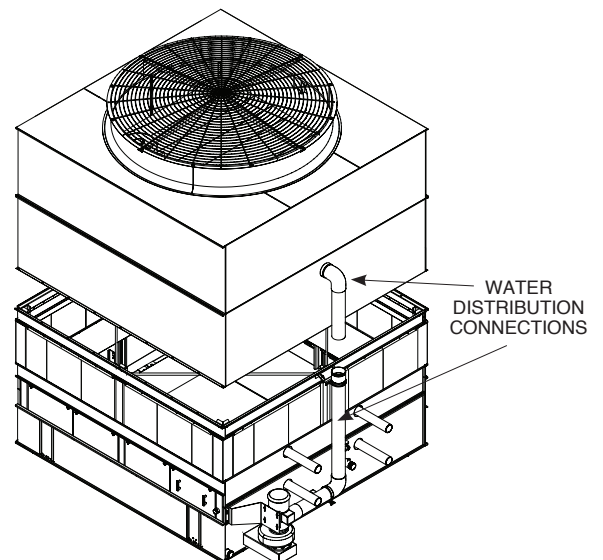

Figure 9 – Mating Upper Section to Bottom Section.

3-Section Shipments

In some cases, a unit is shipped in 3 sections (Fan, Casing and Basin) in lieu of the standard 2 sections (Fan + Casing, and Basin). This is often done to reduce the shipping height of each individual section, which in turn may reduce the size of the crane required to rig the unit.

Casing Section Rigging

All casing sections will be rigged as a four-point lift as shown in **Figure 9a**.

Section Length	Minimum "H" Dimension
14' (4,2 m)	14' (4,2 m)

Table 4 – Minimum "H" Dimension for Four-Point Lift of Cooler Casing Sections

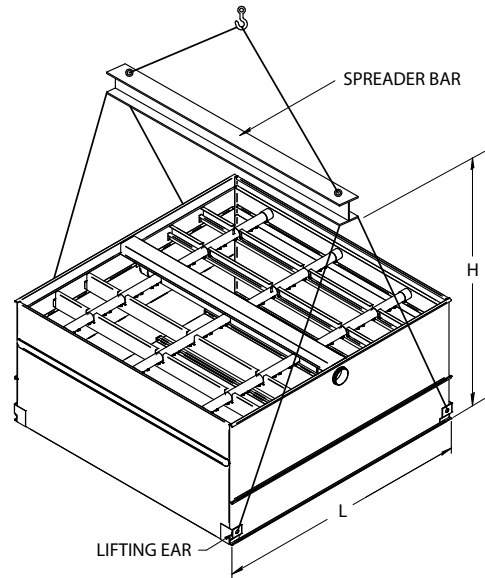

Figure 9a – Four-Point Rigging of Tower Casing Section with Added Lifting Ears

Fan Section Rigging

When lifting the fan section separate from the casing section, the center of gravity of the fan section is heavily biased towards the location of the fan motor and major drive components. In order to avoid lifting the fan section at a lopsided angle, a three-point lift is necessary.

In such a case, an additional lifting ear is provided by the factory on the mechanical bearing support assembly. The "U" bolts on the fan deck which are located close to the fan motor are removed.

Figure 10 shows the proper three-point lifting method for the fan section. The hook of the crane must be a minimum dimension "H" above the top of the section being lifted to prevent undue strain on the "U" bolts.

See Table 5 below for minimum "H" dimension to safely lift the fan section during a three-point lift.

Section Length	Minimum "H" Standard Fan	Minimum "H" Dimension SLSF
14' (4,2 m)	13' (4 m)	13' (4 m)

Table 5 – Minimum "H" Dimension for Three-Point Lifts

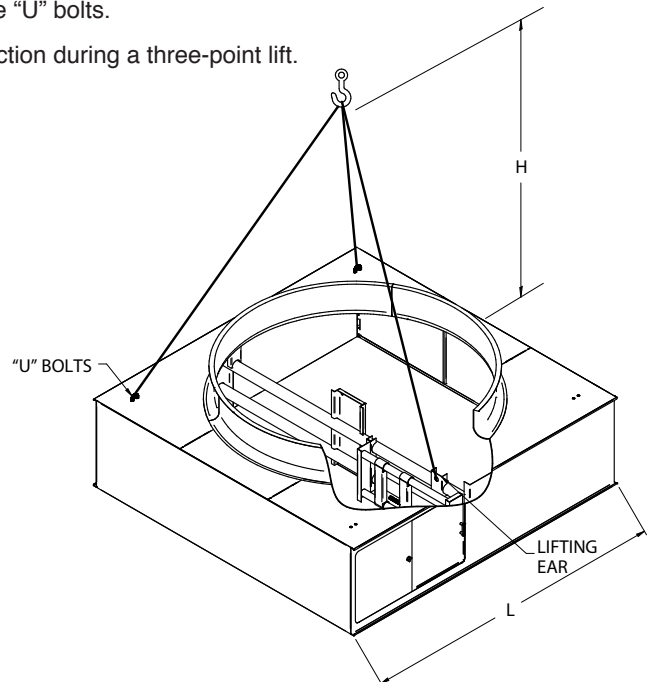

Figure 10 – Three-Point Lift



ESW4 Closed Circuit Coolers

Prior to lowering the fan section onto the casing section, the side flanges on the casing sections must be cleaned by the installer and have sealer tape applied to them. The ends will need to have 2 overlapping layers of sealer tape applied to them. Follow instructions from the "Application of Sealer Tape" section of this manual.

Drift pins should be used to align the fan section with the casing section. The installer will need to attach the fan section end panels to the casing section end panels and the fan section side panels to the casing section side panels with self-threading tappers (galvanized units) or bolts (stainless units).

Note: Fan screen and fan screen support will be shipped loose in the event of a 3-section shipment. Both these items need to be installed after rigging.

Assembly of the Top Section to the Bottom Section

Before securing the upper section to the bottom section, remove any loose parts shipped in the basin.

Wipe the flanges on the bottom of the upper section. Check to see that the water distribution connection on the top section is in the correct position relative to the bottom section (see unit certified drawing). Units are also provided with match markings on each section (i.e. A1 of bottom section should match up with A1 of top section).

Lower the upper section to within several inches of the bottom section making sure the two sections do not touch and the sealer tape is not disturbed. Fasten all four corners. Make use of drift pins to simplify the fastening process.

Install the remaining fasteners, working from the corners towards the center. Fasteners must be installed in every hole in the side flanges. No fasteners are required on the end flanges.

Use of Drift Pins for Final Positioning

Drift pins are tools used to align holes in the flanges of the upper and lower sections of the unit prior to final fastening. By the time drift pins are needed, the lower section of the unit has already been anchored to its support structure. The sealer tape has been laid down on the lower section's flanges, and the upper section is now hovering over the lower section.

A drift pin should be driven in to each of the corner bolt holes such that the upper and lower flanges are aligned as best as possible with sideways motion restricted.

On units which are longer than 12' (3,6 m) ("L" > 12' (3,6 m)), a drift pin should be used at an intermediate pair of bolt holes in the rigging seam to allow for proper alignment.

Notes:

Bolts can be driven upward through the mating flanges if access is restricted.

All rigging hardware is provided by EVAPCO. Drift pins are by others.

Mounting Fan Screens

12' (3,6 m) and 14' (4,2 m) wide units will be shipped with the fan screens in the basin. Under these circumstances use the following procedures to mount the fan screen on the discharge cylinder.

WARNING: DO NOT WALK ON THE FAN SCREENS AT ANY TIME!

1. Lay both halves of the fan screen on the ground. Join the two screen halves with wire clips (Figure 11). There should be 4 wire clips on each side of the fan screen for 12' (3,6 m) and 14' (4,2 m) wide units. Space the wire clips evenly across the radius of the fan screen as shown in Figure 12.
2. The fan screen is supported from underneath by an "X" shaped support frame. Set the support frame across the top of the discharge cylinder (See Figure 13), and fasten to cylinder with 3/8" (10 mm) bolts.
3. Place the fan screen on top of the support frame and discharge cylinder. Each half will be tagged to match markings on the cylinder. Align the eyelets of the fan screen with the holes on the perimeter of the discharge cylinder.
4. At each hole, attach the fan screen to the discharge cylinder as shown in Figure 14.

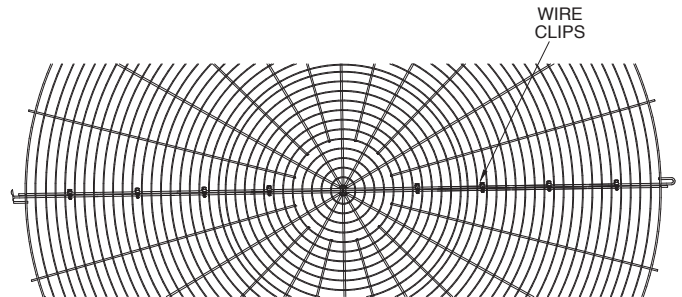

Figure 12 – Wire Clip Spacing

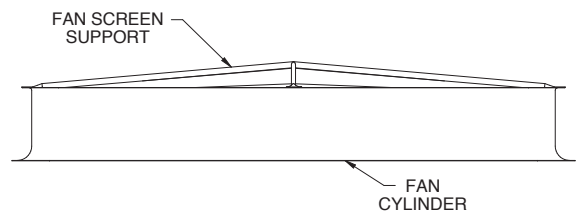

Figure 13 – Support Frame Installation

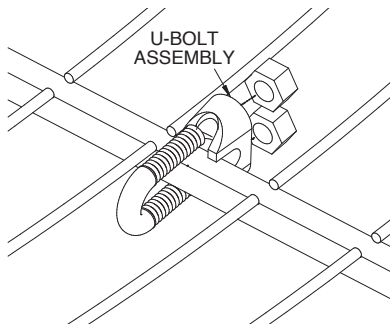

Figure 11 – Wire Clip Arrangement

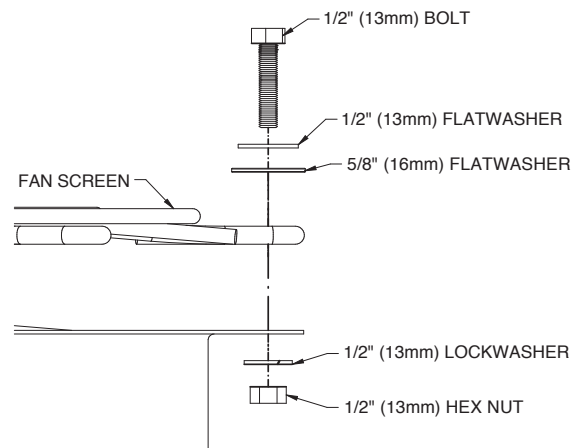

Figure 14 – Attaching Fan Screen to Cylinder

External Motor Installation (applicable to 8.5' (2,6m) wide models only)

8.5' (2,6m) Wide Models

1. Study Figure 15 before installing the motor base on the unit.
2. Insert the lifting device into "U" bolt **A** on motor base **B**.
3. Lift the motor base and insert the pivot pin **C** down into hole **E** and pivot pin **F** into hole **D**.
4. Install washer and nut (do not overtighten) on pivot pins. Install jam nut on pivot pin **C**.
5. Insert "J" bolts **G** into holes **H**. Install flat washers and cotter pins. Place nuts and washers on threaded portion of "J" bolts. These will be behind the motor base installed in the next step.
6. Insert "J" bolts into holes **J** in the motor base. Install flat washers, lock washer and nuts. Remove lifting device from the "U" bolt on the motor base. Position motor base toward casing of unit for belt installation.
7. Install Powerband belt **K** (Figure 16) around fan sheave and motor sheave. Tighten belt by adjusting nuts on "J" bolts. Do not over tighten the belts. The center of the belt should deflect approximately 3/4" (19 mm) with moderate hand pressure.
8. Measure to see that the top and bottom of the motor base are the same distance out from the casing of the unit. This should ensure that the sheaves are properly aligned as they have been pre-set at the factory.
9. As a final check, lay a straight edge from sheave to sheave. There should be four point contact (See Figure 17). Adjust the position of the motor sheave as necessary.
10. To install Motor Guard **L**, match up hinges and install hinge pins **M** (See Figure 16).
11. Close Motor Guard and install two (2) wing bolts **N**.

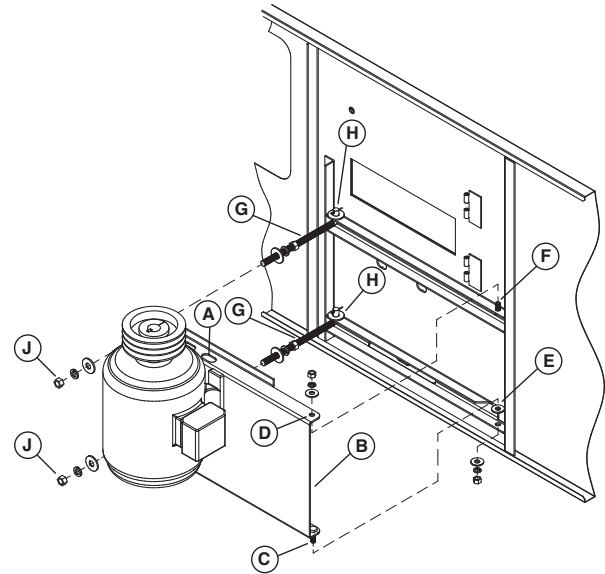

Figure 15 – External Motor Installation

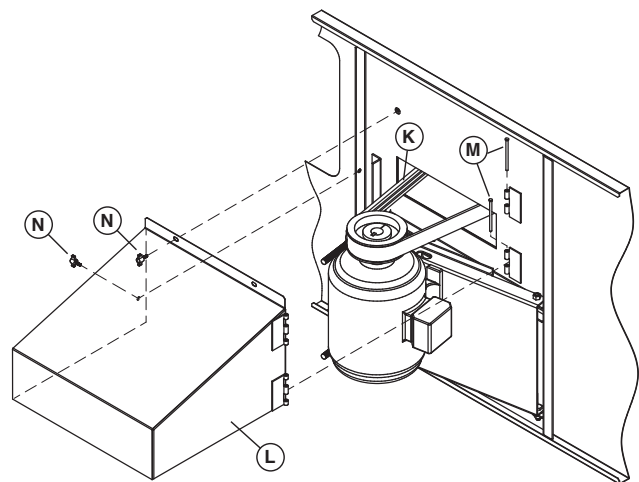

Figure 16 – Motor Guard and Powerband Belt Installation

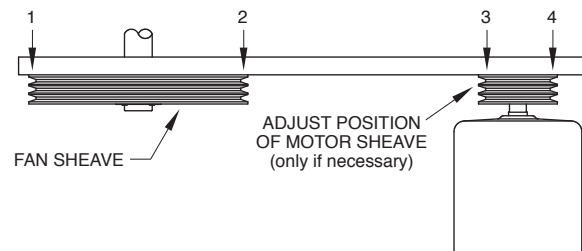

Figure 17 – Sheave Alignment Check

Optional Motor Davit

This accessory is available to aid in the removal of fan motors and gear boxes. The assembly consists of a davit and a mounting base/channel that is attached to the side of the unit next to the access door (Figure 18). Both of these items will ship loose in the unit's basin.

Use the following procedure to install the mounting channel:

1. Place the mounting channel on the factory-installed mounting brackets near the access door.
2. At each hole, attach the mounting channel to the bracket using 3/8" (10 mm) hardware as shown in Figure 19.

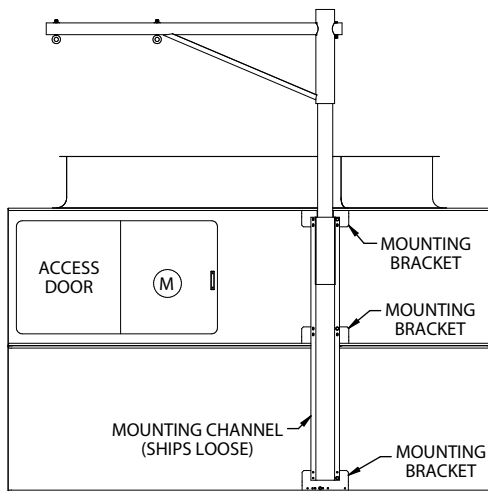

Figure 18 – Dual-Point Davit Arrangement

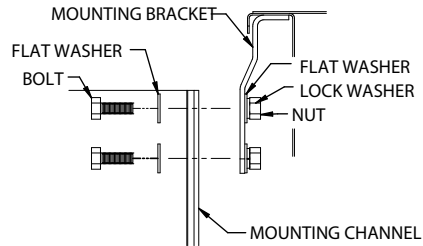

Figure 19 – Attaching Mounting Channel to Mounting Bracket

Optional Heater Package

This accessory is available to prevent the basin water from freezing during winter operation. The heater package consists of a heater, a low water cutout switch and a thermostat. The heater is installed at the factory. The low water cutout switch is shipped loose in the rigging box and will need to be screwed into the screw tight fitting installed in the unit. The thermostat is attached to the side of the unit at the factory. The bulbwell for the thermostat is shipped loose in the rigging box and will also need to be screwed into the screw tight fitting installed in the unit. See Figure 20 for heater package location diagrams.

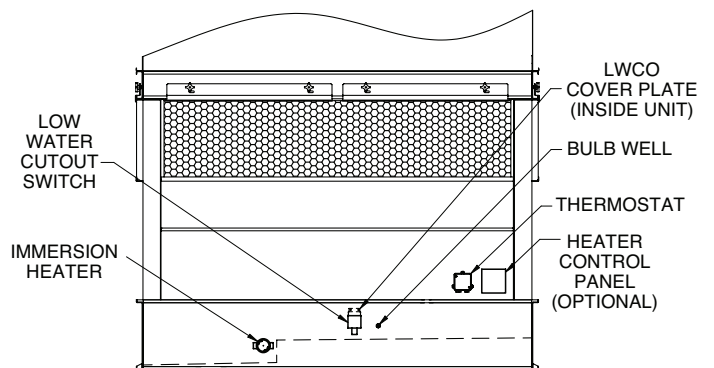

Figure 20 – Heater Component Location

Optional Sloped Ladders

When sloped ladders are supplied with a unit, they are shipped in the basin section, if there is room. One sloped ladder will be provided for each cell. Assembly is identical for each cell.

Sloped ladders are attached at a minimum of three points. Taller units will have four attachment points. At each point of attachment, the ladder will be fitted with a ladder bracket assembly. The ladder bracket assembly looks like a metal box and is shown in detail (component #4) in Figure 21 below. The upper two assembly brackets are factory mounted to the ladder and are not adjustable. These two brackets define the slope of the ladder. The lower brackets are adjustable. See Figures 22 and 23 for drawing of the final ladder assembly.

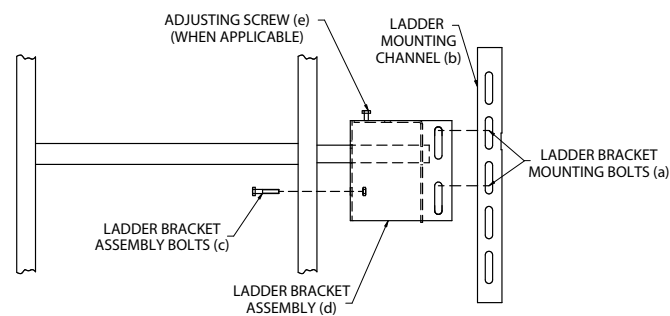

Figure 21 – Detail of Ladder, Ladder Bracket Assembly and Mounting Channel

To install the ladder assembly, follow the steps outlined below which refer to Figure 21:

1. Remove the ladder bracket mounting bolts (a) from the ladder mounting channels (b) on pan and casing sections.
2. Loosen, but do not remove, the ladder bracket and assembly bolts (c).
3. Slide the ladder bracket assembly (d) over the ladder mounting channel (b) located on the unit panels. Do not remove the ladder bracket assembly (d) from the ladder.
4. Align the bolt holes and reinstall the ladder bracket mounting bolts (a) through the ladder bracket assembly and the ladder mounting channels (b).
5. Tighten all bolts.
6. Tighten the adjusting screw (e) in the adjustable mounting bracket where applicable.

NOTE: Upper Section of Unit Must Be Properly Oriented with Respect to Lower Section. All Mounting Brackets Must be on Same Side of Unit. Refer to Certified Print For Proper Orientation.

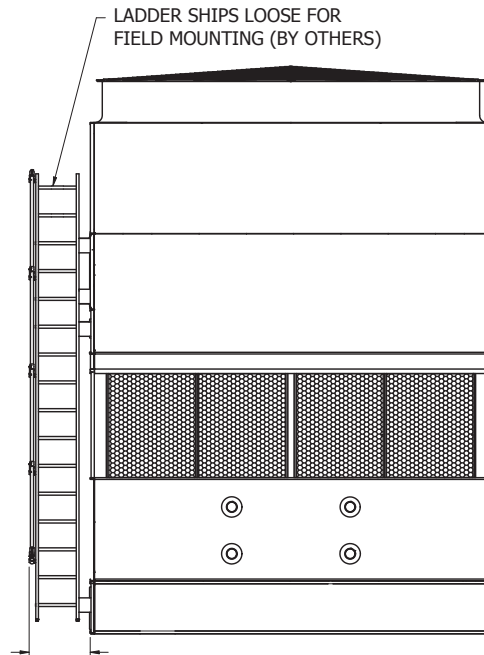

Figure 22 – End View of Ladder Assembly

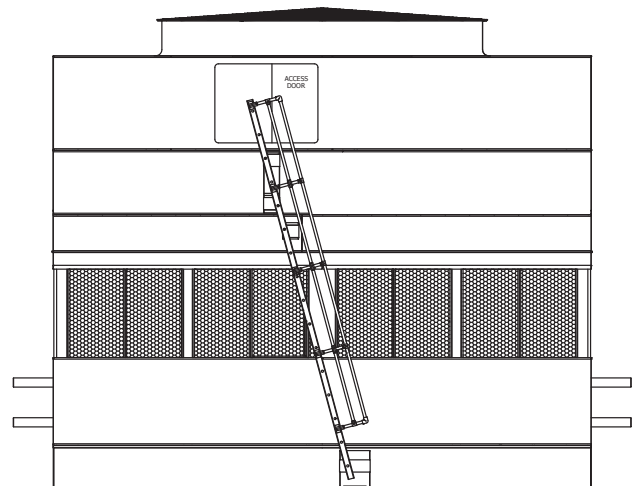

Figure 23 – Side View of Ladder Assembly

Optional Working Platform and Ladder

The working platform and ladder will either be shipped in the basin or shipped separately due to basin accessories that interfere with storage. The platform is partially assembled prior to shipment for minimal field assembly.

The platform and ladder assembly should be attached after the unit is fully rigged. Follow the instructions below.

CONFIDENTIAL
This document is the property of Evapco, Inc. It should not be copied or disclosed without prior written authorization.

PART NO. **058-00023GA** REV. NO. **1**

DETAIL A

DIAGONAL SUPPORT

DECK SUPPORT

DETAIL B

DECK SUPPORT

DIAGONAL SUPPORT

SECURE DECK SUPPORT TO CONNECTION PLATES USING 5/8" GRADE 5 HARDWARE

SECURE RAILING FITTING TO FRONT TOEPLATE USING 3/8" GRADE 5 HARDWARE

SECURE RAILING FITTING TO CONNECTION PLATES USING 5/8" GRADE 5 HARDWARE

SECURE DECK SUPPORT TO CONNECTION PLATES USING 5/8" GRADE 5 HARDWARE

SECURE LADDER CHANNELS TO LOWER CHANNEL ASSEMBLY ON UNIT USING 3/8" GRADE 5 HARDWARE

LOWER CHANNEL ASSY

LADDER CHANNEL

FRONT TOEPLATE

RAILING FITTING

CONNECTION PLATE

CONNECTION PLATE

DIAGONAL SUPPORT

DETAIL C

DETAIL D

DETAIL E

NOTES:

1. PLATFORM GRATING NOT SHOWN FOR CLARITY.

SEND THIS DRAWING TO THE SHIPPING DEPARTMENT TO BE PLACED IN THE RIGGING PACKAGE

EVAPCO, INC.	
TITLE	FIELD ASSY PLATFORM GEN ARR
GA	CUT SIZE
DATE	N.C. INFO.
4/29/15	N.T.S.
DRAWN BY	CHKD BY
NLN	
NEXT ASSEMBLY:	PART NO.
	058-00023GA
	REV. NO. 1

REVISIONS	REPLACED SAFETY CHAINS W/ SWING GATE. 07/24/18 AMG
STAINLESS STEEL OPTION	NOTE: 1. ALL 1/4" HOLES SHOULD BE 11/32" 2. USE STAINLESS STEEL N.C. SET-UP SHEET

General Information - Start-up & Maintenance Start-up Details

Shipping Chocks and Debris

Remove any chocks that have been placed inside the unit for shipping purposes. Be sure to remove the chocks from between the fan and fan guard if applicable. Clean all debris from the basin prior to start-up. Clean and secure all access doors.

Pump Discharge Line

Connect the riser pipe from the pump discharge on the basin section to the riser pipe on the coil/fan section using the flexible connection and hose clamps provided.

Bleed-off Line

A bleed-off line and valve are installed on the unit when shipped with a pump. On units shipped without a pump (remote sump applications) make sure a bleed-off line and valve are properly sized and installed on the discharge side of the pump and connected to a convenient drain. In either case, the bleed-off valve should be fully open.

Strainer

Check the strainers, if applicable, in the basin section to make certain they are in the proper location over the pump suction, along side of the anti-vortex hood. (See Figure 24)

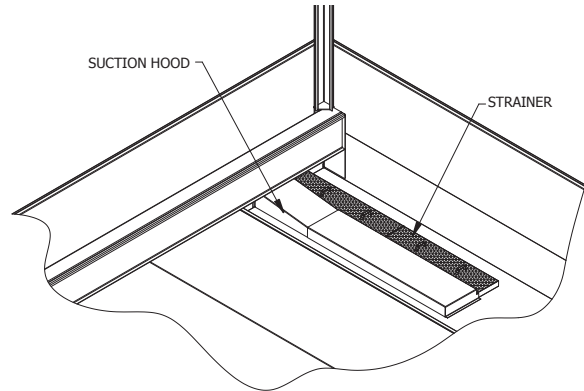

Figure 24 – Strainer Location

Screens

Protective fan screens are provided across the top of the fan cylinders of all models. Check and tighten all bolts.

Float Valve Adjustment

The float valve is pre-set at the factory; however, adjustment should be checked after rigging. The float valve should be adjusted so that the centerline of the float is at the measurement shown in Table 6 from the basin bottom. Raise or lower the float by using the wing nuts on the vertical threaded rod only. Do not adjust the horizontal rod.

Unit Width	Level
8.5' (2,6 m)	9" (23 cm)
12' (3,6 m)	10" (30 cm)
14' (4,2 m)	9" (23 cm)

Table 6 – Recommended Water Level

Starting Sequence

Before starting the unit, check that all access openings, safety screens and covers are in place. Start the unit as outlined below:

1. Fill the pan to the overflow level.
2. Bump start and check the spray water pump(s) for proper rotation. Directional arrows are found on the pump impeller housing.
3. Bump start and check the fan(s) for proper rotation. Directional arrows are placed on the side of the fan cylinder.

Maintenance

Once the installation is complete and the unit is turned on, it is important that it be properly maintained. Maintenance is not difficult or time-consuming but must be done regularly to assure full performance of the unit. Refer to the operation maintenance instructions enclosed with the unit for proper maintenance procedures.

Freeze Protection

Proper freeze protection must be provided if the unit is located in a cold climate. Refer to the operation maintenance instructions as well as product bulletins for further information.

Accessories

Accessories can ship in a variety of locations depending on the type of accessory, the size of the unit and the other accessories purchased with the unit. See Table 7 for a guide to accessory location.

Unit Accessories	Shipping Location
Aluminum Ladder	Shipping Location is Unit and Accessory Dependent - If Space is Available: Strapped Inside Unit Basin - If No Space is Available: Shipped Separately on Truck Bed
Drip Channels for Multi Cell Units	Strapped Inside Unit Basin
Discharge Attenuation	Mounted Loosely Bolted on Basin Section
Electric Basin Heater	Shipping Location is Unit Dependent - End Mounted Heater: Installed in Unit Basin - Side Mounted Heater: Strapped Inside Basin Section
Electric Basin Heater Control Panel	Shipping Location is Dependent on Control Panel Size - If Space is Available: Mounted on Unit Basin - If No Space is Available: Boxed, Wrapped and Wire Tied Inside Basin Section
Electric Basin Heater Low Water Cutout	Shipped in Rigging Box
Electric Basin Heater Thermostat	Shipping Location is Unit Dependent - End Mounted Thermostat: Mounted on Basin Section - Side Mounted Thermostat: Shipped in Rigging Box
Electronic Water Level Control Probes	Mounted in PVC standpipe
Electronic Water Level Control PVC Standpipe	Strapped Inside Unit Basin
External Service Platform with Ladder	Shipping Location is Unit and Accessory Dependent - If Space is Available: Strapped Inside Basin Section - If No Space is Available: Crated and Shipped Separately on Truck Bed
Factory Mounted Crossover Piping	Welded to Coil Connections
Fan Motor	Shipped Loose on 8,5' (2,6 m) Wide Units
Fan Screens (If not mounted)	Shipping Location is Unit and Accessory Dependent - If Space is Available: Strapped Inside Basin Sections - If No Space is Available: Crated and Shipped Separately on Truck Bed
Fan Screen Supports (If not mounted)	Shipping Location is Unit and Accessory Dependent - If Space is Available: Strapped Inside Basin Section - If No Space is Available: Crated and Shipped Separately on Truck Bed
Hot Water or Steam Coil	Installed in Unit Basin
Low Water Cutoff for Pump	Shipped in Rigging Box
Motor Davit and Base	Shipping Location is Unit and Accessory Dependent - If Space is Available: Strapped Inside Basin Section - If No Space is Available: Crated and Shipped Separately on Truck Bed
Remote Sump Trash Screen	Installed In Unit Basin
Rigging Hardware	Shipped in Rigging Box
Safety Cage	Attached to the Ladder
Sealer Tape	Shipped in Rigging Box
Sump Sweeper Piping with and without High Flow Eductors	Installed in Unit Basin
Vibration Switch	Mounted in Fan Section
Water Level Indicator	Strapped Inside Unit Basin

Table 7 – Unit Accessory Shipping Location

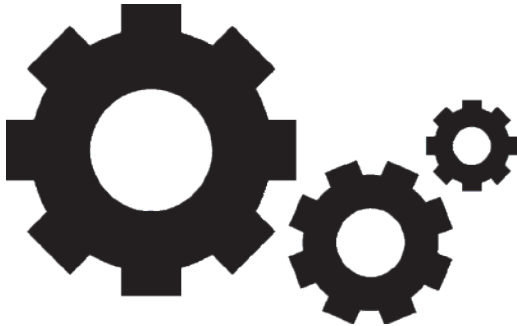

FOR EVAPCO AUTHORIZED PARTS AND SERVICE, CONTACT YOUR LOCAL EVAPCO REPRESENTATIVE OR THE LOCAL SERVICE CENTER



Mr. GoodTower®



EVAPCO, Inc. — World Headquarters & Research/Development Center

P.O. Box 1300 • Westminster, MD 21158 USA
410.756.2600 • marketing@evapco.com • evapco.com

North America

EVAPCO, Inc.
World Headquarters
Westminster, MD USA
410.756.2600
marketing@evapco.com

EVAPCO East
Taneytown, MD USA

EVAPCO East
Key Building
Taneytown, MD USA

EVAPCO Midwest
Greenup, IL USA
217.923.3431
evapcomw@evapcomw.com

Evapcold Manufacturing
Greenup, IL USA

EVAPCO Newton
Newton, IL USA
618.783.3433
evapcomw@evapcomw.com

EVAPCO West
Madera, CA USA
559.673.2207
contact@evapcowest.com

EVAPCO Alcoil, Inc.
York, PA USA
717.347.7500
info@evapco-alcoil.com

EVAPCO Iowa
Lake View, IA USA

EVAPCO Iowa
Sales & Engineering
Medford, MN USA
507.446.8005
evapcomn@evapcomn.com

EVAPCO LMP ULC
Laval, Quebec, Canada
450.629.9864
info@evapcolmp.ca

EVAPCO Select Technologies, Inc. Bel-
mont, MI USA
844.785.9506
emarketing@evapcoselect.com

**Refrigeration Vessels &
Systems Corporation**
Bryan, TX USA
979.778.0095
rvs@rvscorp.com

Tower Components, Inc.
Ramseur, NC USA
336.824.2102
mail@towercomponentsinc.com

EvapTech, Inc.
Edwardsville, KS USA
913.322.5165
marketing@evaptech.com

EVAPCO Dry Cooling, Inc.
Bridgewater, NJ USA
908.379.2665
info@evapcodc.com

EVAPCO Dry Cooling, Inc.
Littleton, CO USA
908.895.3236
info@evapcodc.com

EVAPCO Power México S. de R.L. de C.V.
Mexico City, Mexico
(52) 55.8421.9260
info@evapcodc.com

Asia / Pacific

**EVAPCO Asia Pacific
Headquarters**
Baoshan Industrial Zone Shanghai, P.R. China
(86) 21.6687.7786
marketing@evapcochina.com

**EVAPCO (Shanghai)
Refrigeration Equipment Co., Ltd.**
Baoshan Industrial Zone, Shanghai, P.R. China

**EVAPCO (Beijing)
Refrigeration Equipment Co., Ltd.**
Huairou District, Beijing, P.R. China
(86) 10.6166.7238
marketing@evapcochina.com

**EVAPCO Air Cooling Systems
(Jiaxing) Company, Ltd.**
Jiaxing, Zhejiang, P.R. China
(86) 573.8311.9379
info@evapcochina.com

EVAPCO Australia (Pty.) Ltd.
Riverstone, NSW, Australia
(61) 02.9627.3322
sales@evapco.com.au

**EvapTech (Shanghai)
Cooling Tower Co., Ltd.**
Baoshan District, Shanghai, P.R. China.
Tel: (86) 21.6478.0265

EvapTech Asia Pacific Sdn. Bhd.
Puchong, Selangor, Malaysia
(60) 3.8070.7255
marketing-ap@evaptech.com

Europe | Middle East | Africa

**EVAPCO Europe
EMENA Headquarters**
Tongeren-Borgloon, Belgium
(32) 12.39.50.29
info@evapco.be

EVAPCO Europe BV
Tongeren-Borgloon, Belgium

EVAPCO Europe, S.r.l.
Milano, Italy
(39) 02.939.9041
evapcoeuropa@evapco.it

EVAPCO Europe, S.r.l.
Sondrio, Italy

EVAPCO Europe A/S
Aabybro, Denmark
(45) 9824.4999
info@evapco.dk

EVAPCO Europe GmbH
Meerbusch, Germany
(49) 2159.69560
info@evapco.de

EVAPCO Middle East DMCC
Dubai, United Arab Emirates
(971) 56.991.6584
info@evapco.ae

Evap Egypt Engineering Industries Co.
A licensed manufacturer of EVAPCO, Inc.
Nasr City, Cairo, Egypt
(202) 10 054 32 198
evapco@tiba-group.com

EVAPCO S.A. (Pty.) Ltd.
A licensed manufacturer of EVAPCO, Inc.
Isando, South Africa
(27) 11.392.6630
evapco@evapco.co.za

South America

EVAPCO Brasil
Equipamentos Industriais Ltda.
Indaiatuba, São Paulo, Brazil
(55) 11.5681.2000
vendas@evapco.com.br

FanTR Technology Resources
Itu, São Paulo, Brazil
(55) 11.4025.1670
fantr@fantr.com

TECHNOLOGY FOR THE FUTURE, AVAILABLE TODAY

Visit EVAPCO's websites: www.evapco.eu / www.mrgoodtower.eu