

Rigging & Assembly Instructions

C-ATC / C-ATW

CONTAINERIZED
EVAPORATIVE CONDENSERS
AND
CLOSED CIRCUIT COOLERS



Mr. GoodTower®

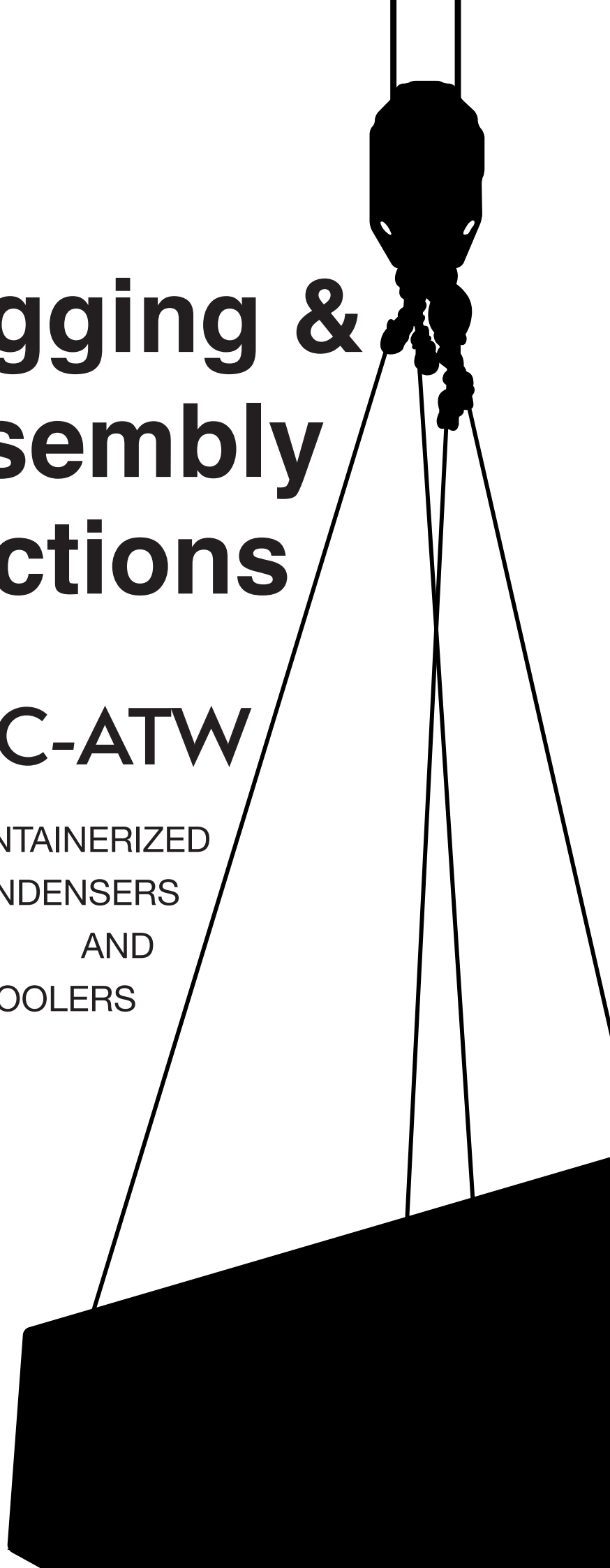

Method of Shipment

The C-ATC / C-ATW product line has been designed to fit in a standard shipping container. C-ATC condensers and C-ATW coolers are shipped with the top (fan) and bottom (basin) sections (less vertical supports) mounted together for shipment, as shown in Figure 1. The middle (coil) section is shipped separately, as shown in Figure 2. These sections have mating flanges and will join together in a waterproof joint when sealed and bolted together as described in the following instructions. The vertical supports, all ancillary

equipment, and parts ship disassembled and packaged in the basin section. Miscellaneous items, such as sealer tape, selftapping screws and any other required materials, are packaged and placed inside the rigging box and shipped in the basin section as well, as shown in Figure 3.

NOTE

All stainless steel rigging bolts should be coated with anti-seize spray on the threads to prevent nut galling.

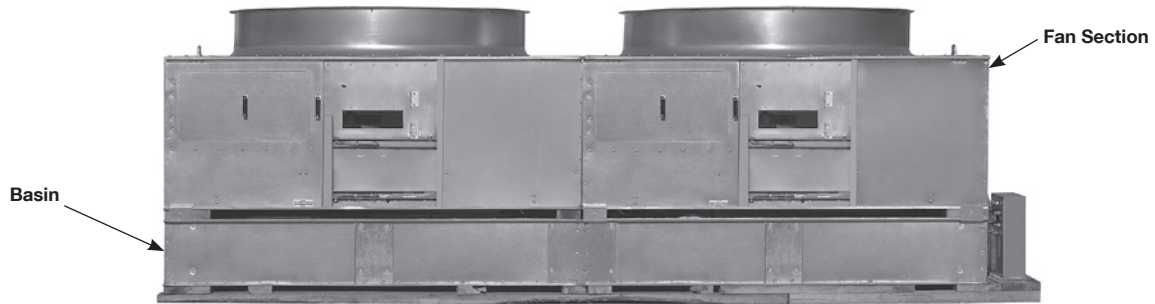

Figure 1 – Skidded fan and basin sections

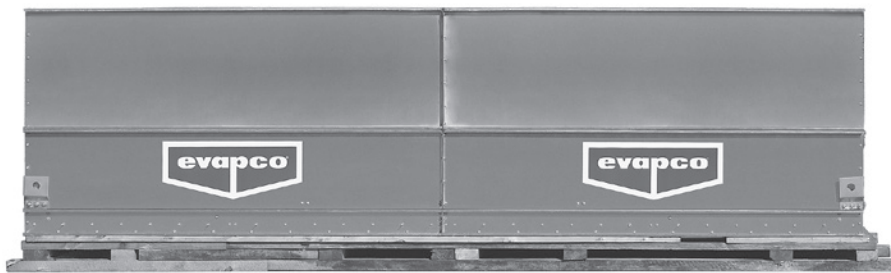

Figure 2 – Skidded coil section

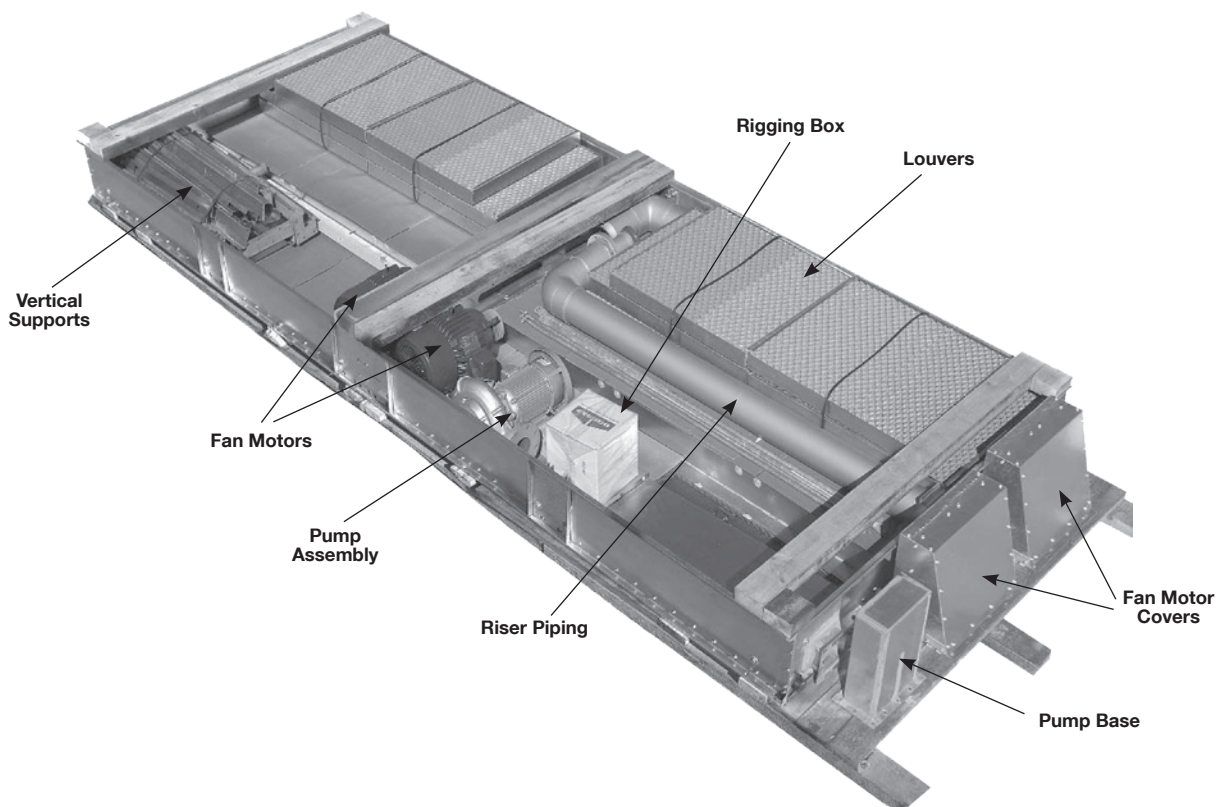

Figure 3 – Basin shipping arrangement

Storage & Excessive Heat Precautions

The temperature inside shipping containers can be significantly higher than ambient outdoor temperatures. Since excessive heat build-up can cause damage to the PVC components such as drift eliminators or air inlet louvers, units shipped to or through particularly hot climates should utilize 'open top' shipping containers or otherwise make arrangements to have the PVC components shipped separately. Do not place tarps or other coverings over the top of the units. Tarps could have a similar heat trapping effect resulting in damage to PVC components. For extended storage beyond six months, rotate the fan and fan motor shaft(s) monthly. The fan shaft bearings should be purged and re-greased prior to start-up.

Unloading

WARNING! Caution must be exercised when handling the loaded shipping container. The C-ATC / C-ATW sections are of unequal weight and may cause excessive shifting or tilting of the container during handling.

C-ATC condensers and C-ATW coolers are loaded into shipping containers with the coil section closest to the door. This minimizes the handling of this (heaviest) section and facilitates unloading of all components. Evapco recommends that C-ATCs and C-ATWs be unloaded from their shipping containers at the receiving port and transported to the final destination using a flatbed truck. Unloading of both sections can be achieved by the use of straps or chains looped through the skid of each section and connected to a forklift.

If a loading dock is available at the jobsite, the container may be transported to its final destination and similarly unloaded. However, if a loading dock is not available the container can be off-loaded to ground level and unloaded using a small ramp to adjust for the height difference between the ground and the inside of the container.

Structural Steel Support

Two structural "I" beams running the length of the unit are required for supporting the unit. These beams should be located underneath the outer flanges of the unit as shown in Figure 4.

Mounting holes, 3/4" (19 mm) in diameter, are located in the bottom flange for bolting to the structural steel (see certified print for exact bolt hole location). Bolt the bottom section to the steel support before rigging the top section. Follow the rigging instructions to ensure proper sequence of section installation.

Beams should be sized in accordance with accepted structural practices. Maximum deflection of the beam under the unit is recommended to be 1/360 of the unit length, not to exceed 1/2" (13 mm). Deflection may be calculated by using 55% of the operating weight as a uniform load on each beam (see certified print for operating weight).

The supporting "I" beams should be level before setting the unit. Do not level the unit by shimming between the bottom flange and the beams as this will not provide proper longitudinal support.

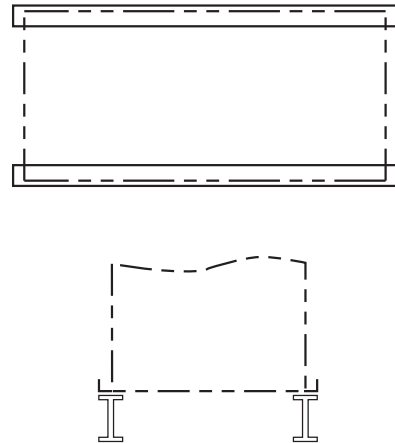

Figure 4 – Steel Support

C-ATC / C-ATW RIGGING AND ASSEMBLY

There are (7) basic steps required to assemble a C-ATC / C-ATW:

- Step #1:** Rig Basin Section
- Step #2:** Remove Fan Section from Basin Section & Rig onto Coil Section
- Step #3:** Install Vertical Supports in Basin Section
- Step #4:** Rig Fan/Coil Section onto Basin section
- Step #5:** Install Pump and Piping
- Step #6:** Install WST Air Inlet Louvers
- Step #7:** Install Motors and Covers

**Step #1
Rig Basin Section**

Lifting devices (U-bolts) are located on the top corners of the basin/fan section for lifting and final positioning as shown in Figure 5. The hook of the crane must be a minimum dimension of “H” above the top of the section being lifted to prevent undue strain on the lifting devices. See Table 1 for the minimum “H” dimension. Rigging beam should be approximately the same length as the unit. If a rigging beam is not used the length of the “H” dimension should remain the same and spreader bars should be used to prevent damage to the unit.



Figure 5 – Lifting arrangement for fan section

Condenser / Cooler Length	Min. “H” Dimension
9 Feet (2.7 meters)	9 Feet (2.7 meters)
12 Feet (3.6 meters)	12 Feet (3.6 meters)
14 Feet (4.3 meters)	14 Feet (4.3 meters)
18 Feet (5.5 meters)	17 Feet (5.2 meters)

Table 1 – Minimum “H” Dimensions for Fan Sections

Remove the fan section from the basin section. Position the basin section on the unit steel supports and bolt into place per Figure 4. Bolt the basin section to the steel support before rigging the fan/coil section. The lifting devices alone should **NOT** be used for extended lifts or where any hazard exists. For extended lifts, safety slings must be provided under the sections in combination with the lifting devices on the unit as shown in Figure 6.

EXTENDED LIFTS
The preferred method for extended lifts is to use slings under the unit (See Figure 6). Spreader bars must always be used between the cables at the top of the section to prevent damage to the upper flanges or fan cylinders.

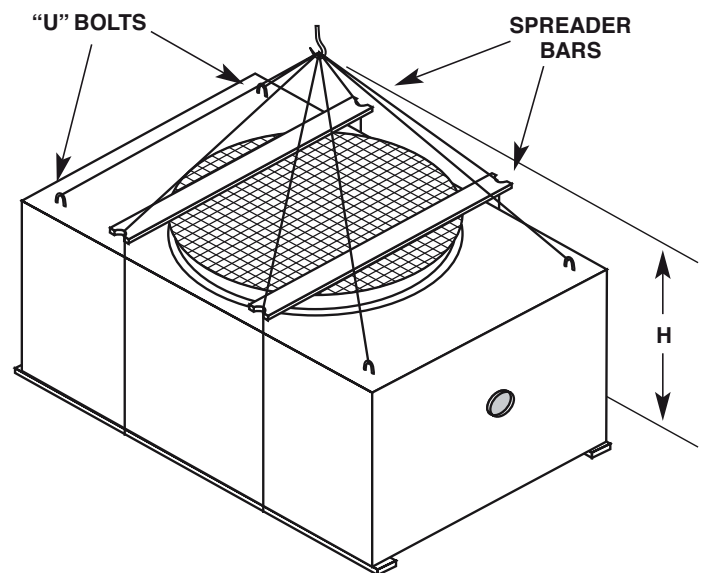

Figure 6 – Extended Lifts

Safety slings and skids should be removed before final positioning of the unit.

Step #2 Remove Fan Section from Basin Section & Rig onto Coil Section

Remove all shipping channels holding basin and fan together by removing the hardware securing the shipping channels to the wood beams and chocks as shown in Figure 7.



Figure 7 – Removal of shipping channels

It is recommended that the fan section be rigged onto the coil section at the time that it is removed from the basin section. This requires that the coil section be pre-positioned within reach of the crane. Alternatively, the fan section can be set aside on a flat and smooth surface and rigged onto the coil section at a later time.

Applying Sealer Tape

Prior to rigging the fan section onto the coil section, sealer tape must be applied. The top flanges on the coil section and bottom flanges on the fan section should be wiped down to remove any dirt or moisture. One layer of sealer tape should be placed over the mounting hole centerline on the side flanges.

Apply two strips of sealer tape, one partially overlapping the other, on the end flanges. The sealer tape should overlap on the corners as shown in Figure 8. Do not splice the sealer tape along the end flanges and preferably not on the side flanges if it can be avoided. **Always remove the paper backing from the sealer tape.**

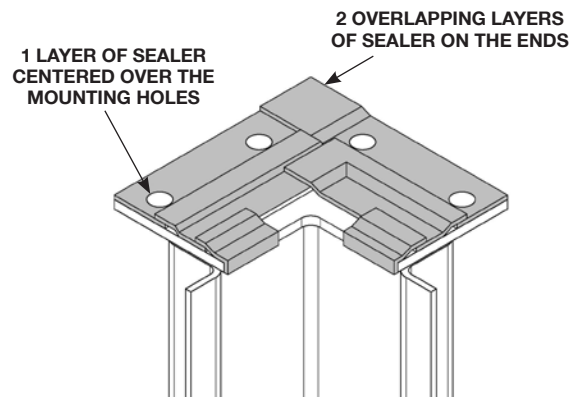

Figure 8 – Proper sealer tape application

The fan section should then be lifted using the U-bolts located at the top corners of the fan section as shown in Figure 9. Note that the unit is provided with match markings on each section (i.e. A1 of coil section should match up with A1 of fan section).



Figure 9 – Lifting of fan section

Lower the fan section to within several centimeters of the coil section, making sure the two sections do not touch and the sealer is not disturbed. Place drift pins (see Figure 10) in the (4) corner mounting holes and gradually lower the fan section into place using the drift pins to guide the section down accurately onto the mating flange. Place self-tapping screws (or stainless steel bolts and nuts in the case of stainless steel construction) in all four corner bolt holes.

Then continue to install the rest of the self-tapping screws working from the corners toward the center, using drift pins to align the holes. A self-tapper must be installed in every hole on the side flanges. No self-tappers are required on the end flanges. The assembled fan/coil section is shown in Figure 11.

NOTE: 5/16" (M8) stainless steel nuts, bolts and washers are used for stainless steel construction.

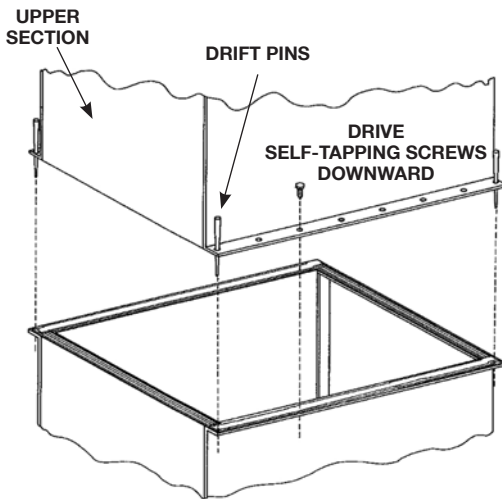

Figure 10 – Mating fan section to coil section



Figure 11 – Assembled fan/coil section

WARNING!
 Never use the fan deck “U” bolts for lifting assembled fan/casing section

Step #3 Install Vertical Supports in Basin Section

Unpack the components shipped in the basin and set them aside near the unit. Prepare the basin section for assembly by matching the marks on the vertical posts with those on the basin brackets and laying out the vertical posts in their proper location, as shown in Figure 12.

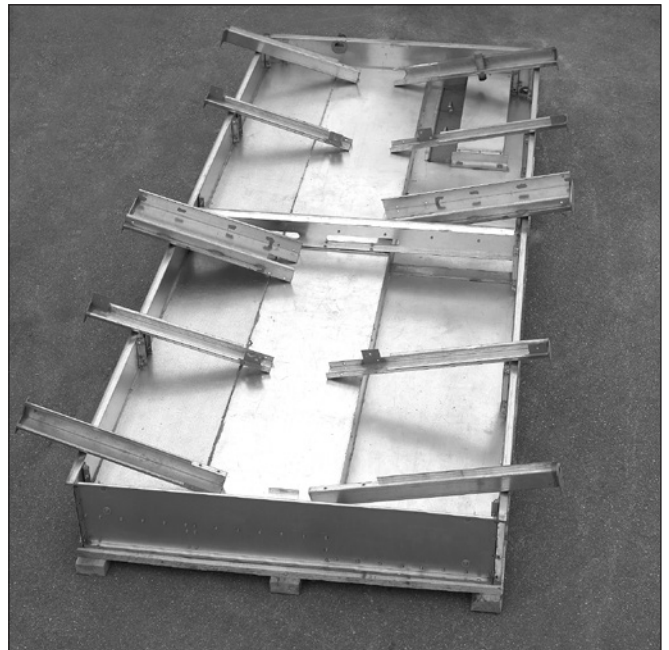
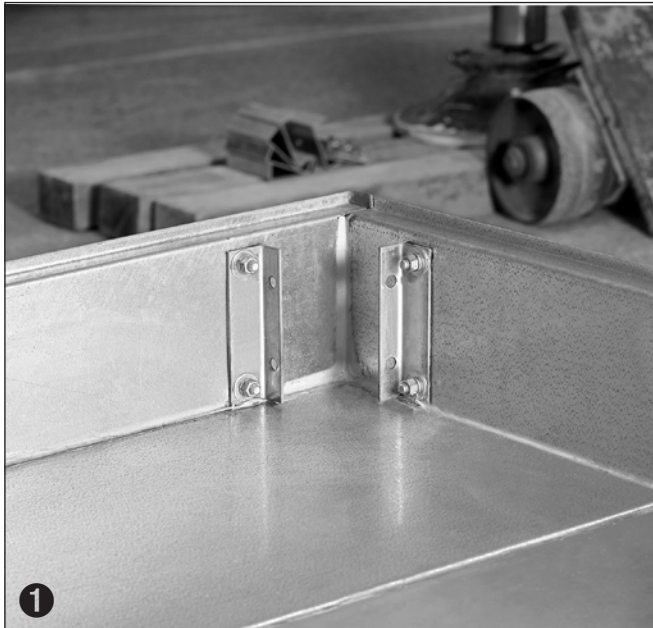

Figure 12 – Vertical posts layout

Install each vertical post using the hardware installed from the factory on each bracket. Ensure that a lock-washer is in place on both sides of the vertical post next to the bolt head

and nut. Installation sequence for each type of vertical post is shown in Figures 13 through 15.



Step #1: Clean corner brackets and locate hardware

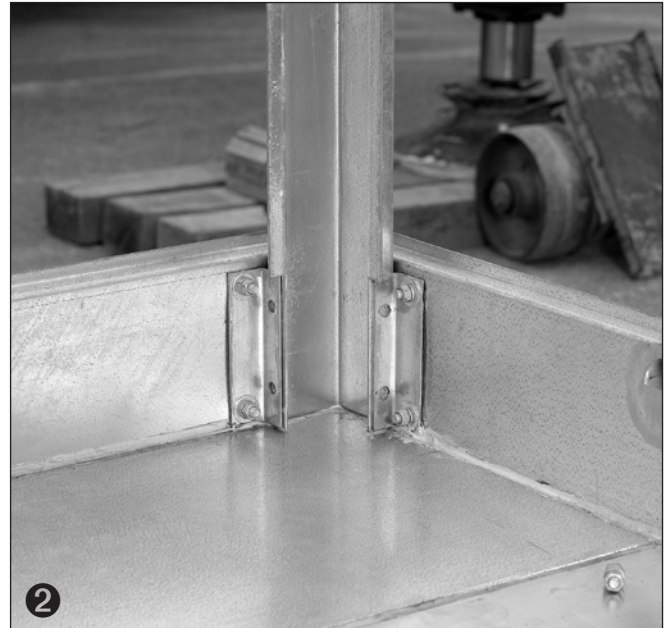

Step #2: Install corner vertical between brackets

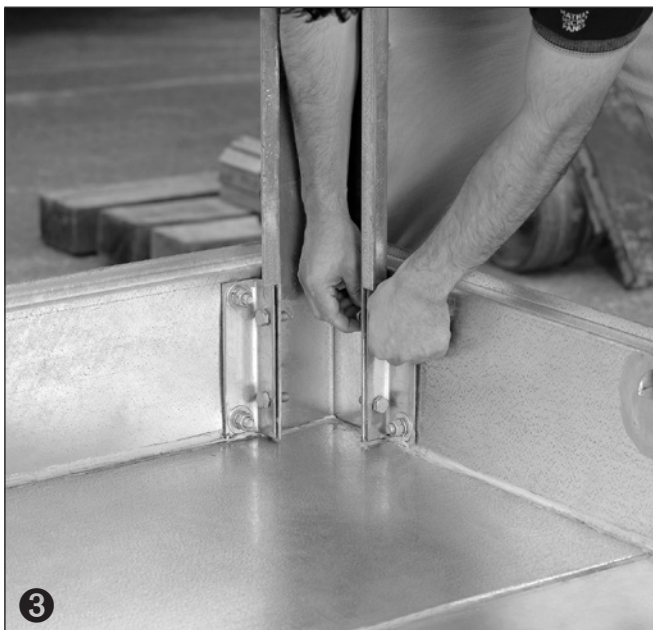

Step #3: Loosely install hardware

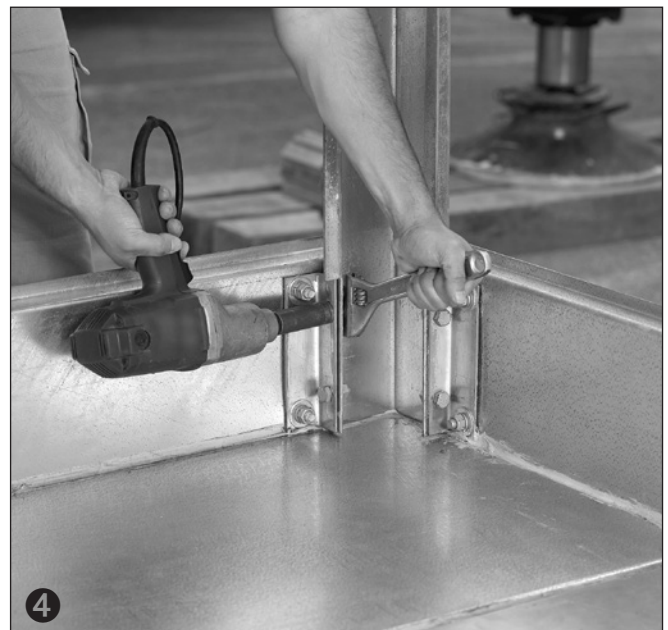

Step #4: Tighten all hardware

Figure 13 – Corner vertical post installation

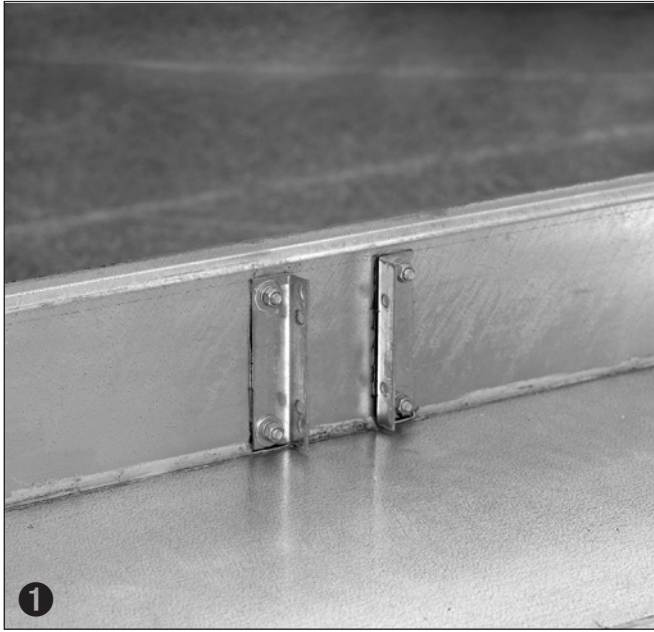

Step #1: Clean brackets and locate hardware in rigging box



Step #2: Install louver vertical support and tighten hardware

Figure 14 – Louver vertical post installation



Step #1: Clean brackets and locate hardware in rigging box



Step #2: Install vertical support and tighten hardware

Figure 15 – Coil support installation (18' [5.5 m] long models only)

The final step in assembling the basin is installing the cross-braces as shown in Figure 16 (use 1/2" x 1-1/4" [M12 x 30] bolts and 1/2" [M12] lock-washer and nut).

Some drilling (9/16 Ø) on vertical support tabs is required.

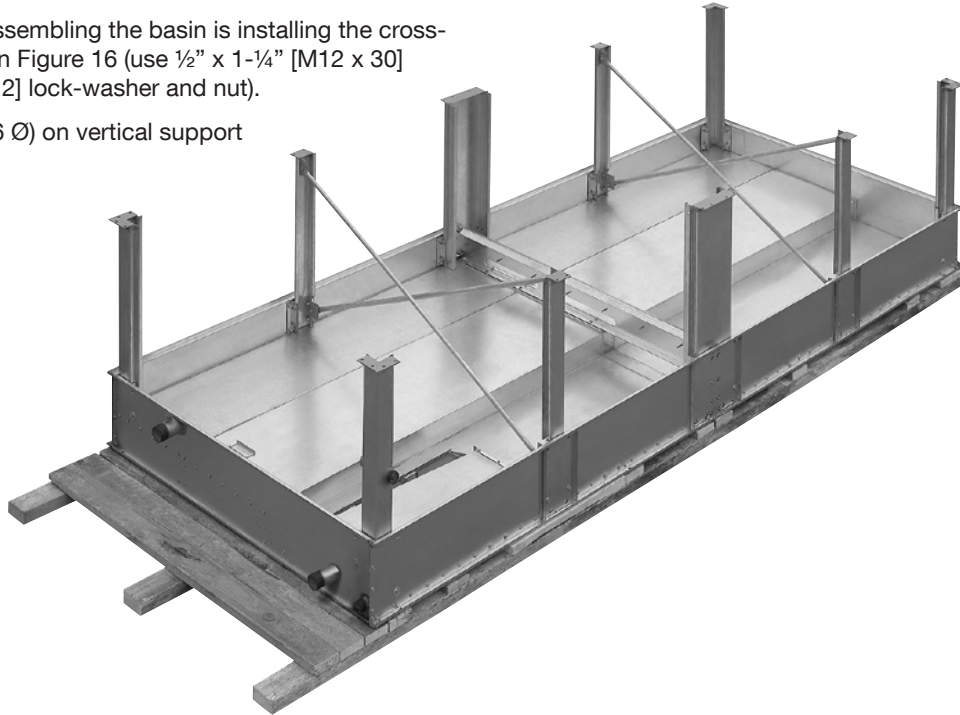

Figure 16 – Assembled basin section

Step #4 Rig Fan/Coil Section onto Basin section

Four lifting ears are provided in the lower corners of the coil section for lifting into final position. **A spreader beam must be used for lifting the top section(s) as shown in Figure 17.**

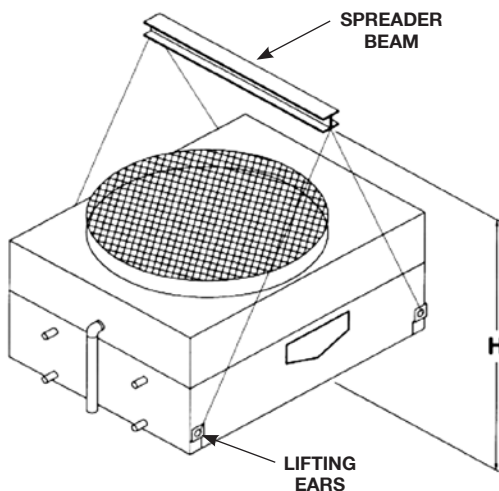

Figure 17 – Four point lift

WARNING!

Never use the fan deck “U” bolts for lifting assembled fan/casing section

The spreader beam must be a minimum dimension “H” above the top section being lifted to prevent undue strain on the lifting ears. See Table 2 for the minimum “H” dimension. These lifting devices should not be used for extended lifts or where any hazard exists unless safety slings are employed under the section. (See “Extended Lifts” in Step #1 for proper arrangement.)

Condenser / Cooler Length	Min. “H” Dimension
9 Feet (2.7 meters)	9 Feet (2.7 meters)
12 Feet (3.6 meters)	12 Feet (3.6 meters)
14 Feet (4.3 meters)	14 Feet (4.3 meters)
18 Feet (5.5 meters)	17 Feet (5.2 meters)

Table 2 – Minimum “H” Dimensions for Fan/coil Sections

Applying Sealer Tape

Prior to rigging the fan/coil sections onto the basin section, sealer tape must be applied. The top surfaces of the basin vertical posts and bottom flanges on the coil section should be wiped down to remove any dirt or moisture. Sealer tape should be placed over the mounting hole centerline on the vertical posts. Apply two strips of sealer tape, one partially overlapping the other. The sealer tape should overlap on the corners as shown in Figure 18. Do not splice the sealer tape along the end flanges and preferably not on the side flanges if it can be avoided.

Always remove the paper backing from the sealer tape.

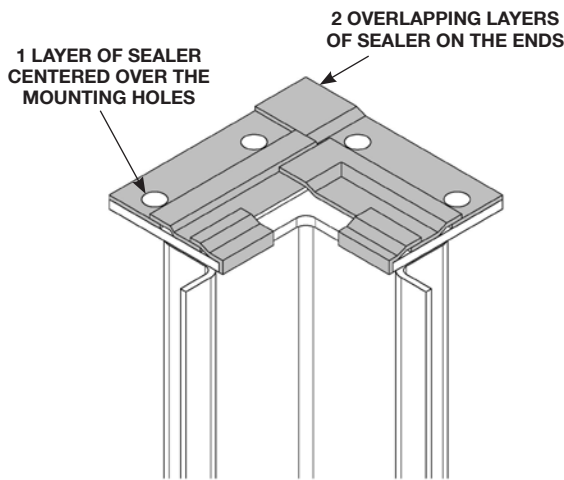

Figure 18 – Proper sealer tape application

Lower the fan/coil section to within several centimeters of the basin vertical posts, making sure the two sections do not touch and the sealer is not disturbed. Place drift pins (see Figure 19) in at least (3) of the corner mounting holes and gradually lower the fan/coil section into place using the drift pins to guide the section down accurately onto the mating vertical posts. Place washers, nuts and bolts in all four corner bolt holes. Then continue to install the rest of the washers, nuts and bolts on the remaining vertical posts.

NOTE: 5/16" (M8) stainless steel nuts, bolts and washers are used for stainless steel construction.

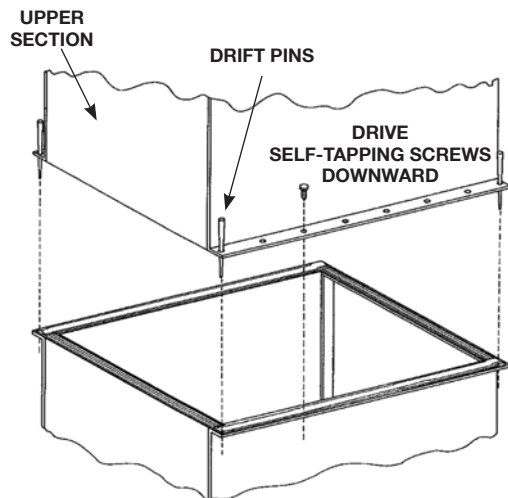

Figure 19 – Mating fan/coil section to basin section

Step #5 Install Pump and Piping

Some C-ATC condensers and C-ATW coolers may be provided with a “detachable” pump assembly to reduce transportation costs. The pump base on these units must be installed as shown in Figure 20 and detailed in Figure 21, ensuring that the gasket is properly placed between the mating flanges. The pump should be mounted to the pump base using the hardware and gasket provided.

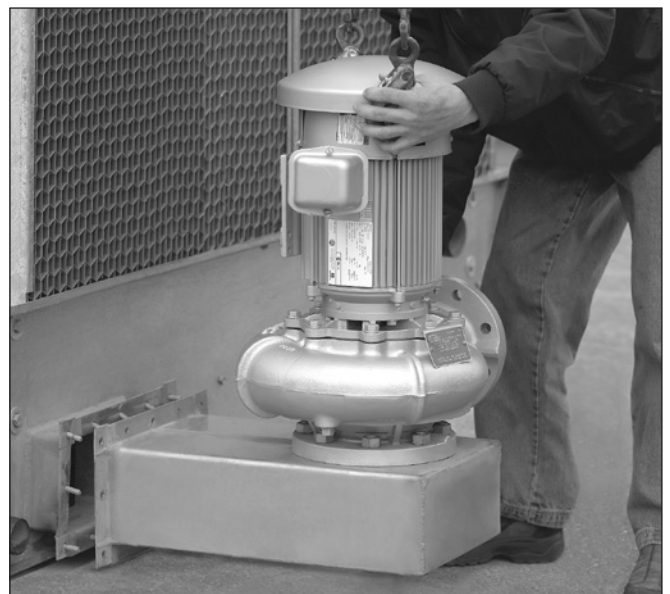

Figure 20 – Detachable pump base assembly

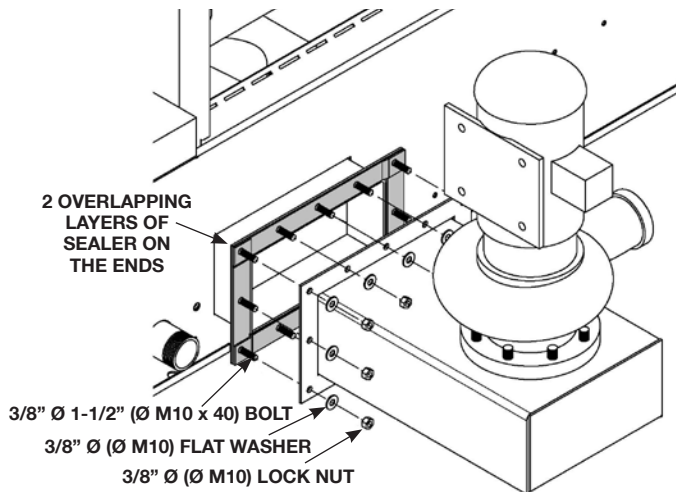

Figure 21 – Detachable pump drawing

Recirculation water piping is provided in large pre-assembled sections and should be installed as shown in Figure 22. Connect the lower riser pipe to the pump discharge using the hardware and gasket provided. The upper elbow pipe should be screwed to the water connection located in the fan section. **Care should be taken when tightening the PVC threaded connections to avoid cracking the fittings.** Connect the riser pipe from the pump discharge on the basin section to the elbow on the fan section using the flexible coupling and hose clamps provided.

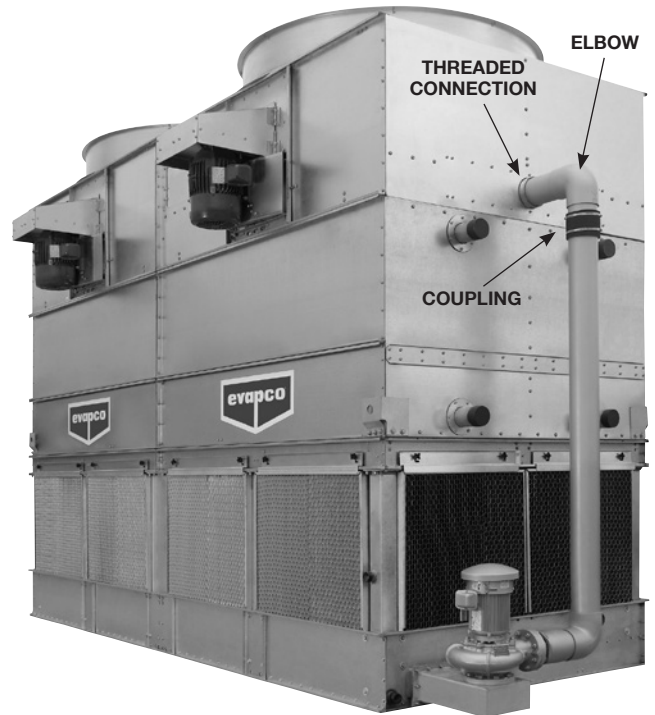

Figure 22 – Recirculation piping assembly

Step #6 Install WST Air Inlet Louvers

Air inlet louvers are shipped with an integral metal frame for ease of handling and maintenance. Install all louvers into place, ensuring that the drain holes are located on the **lower** frame, facing the **interior** of the basin. The louver retaining angles should then be installed and secured with plastic wing-nuts. Finally, install plastic cap on wing-nut bolts to prevent loss of the wing-nuts during maintenance.

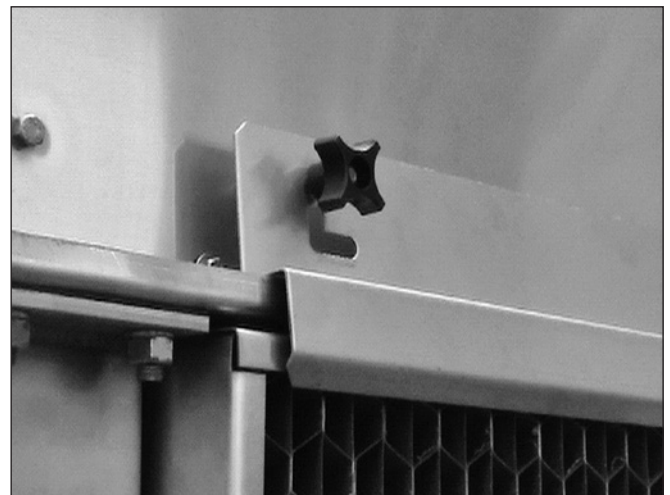

Figure 23 – Installed WST louver

Step #7 Install Motors and Covers

External Motor Installation

8.5' (2.4 m) Wide Models

1. Study Figure 24 before installing the motor base on the unit.
2. Insert the lifting device into "U" bolt **A** on motor base **B**.
3. Lift the motor base and insert the pivot pin **C** down into hole **E** and pivot pin **F** into hole **D**.
4. Install washer and nut (do not overtighten) on pivot pins. Install jam nut on pivot pin **C**.
5. Insert "J" bolts **G** into holes **H**. Install flat washers and cotter pins. Place nuts and washers on threaded portion of "J" bolts. These will be behind the motor base installed in the next step.
6. Insert "J" bolts into holes **J** in the motor base. Install flat washers, lock washer and nuts. Remove lifting device from the "U" bolt on the motor base. Position motor base toward casing of unit for belt installation.
7. Install Powerband belt **K** (Figure 25) around fan sheave and motor sheave. Tighten belt by adjusting nuts on "J" bolts. Do not over tighten the belts. The center of the belt should deflect approximately 3/4" (19 mm) with moderate hand pressure.
8. Measure to see that the top and bottom of the motor base are the same distance out from the casing of the unit. This should ensure that the sheaves are properly aligned as they have been pre-set at the factory.
9. As a final check, lay a straight edge from sheave to sheave. There should be four point contact. (See Figure 26.) Adjust the position of the motor sheave as necessary.
10. To install Motor Guard **L**, match up hinges and install hinge pins **M**. (See Figure 25.)
11. Close Motor Guard and install (2) wing bolts **N**.

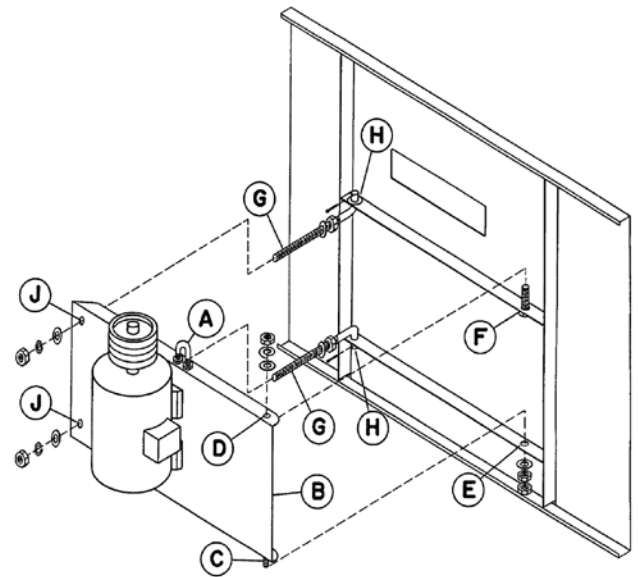

Figure 24 – External motor installation

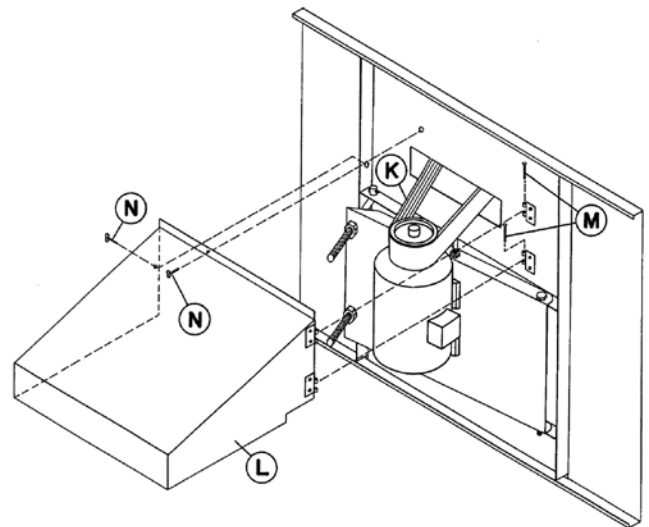

Figure 25 – Motor guard and powerband belt installation

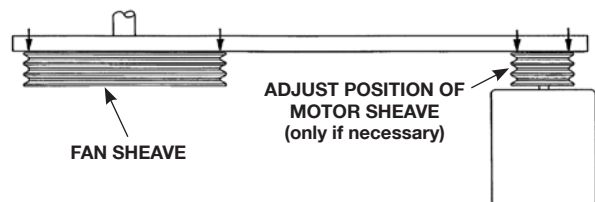

Figure 26 – Sheave alignment check

General Information - Start-up & Maintenance

Start-up Details

Shipping Chocks and Debris

Remove any chocks that have been placed inside the unit for shipping purposes. Be sure to remove the chocks from between the fan and fan guard if applicable. Clean all debris from the basin prior to start-up. Close and secure all access doors.

Bleed-off Line

A bleed-off line and valve are installed on the unit when shipped with a pump. On units shipped without a pump (remote sump applications) make sure a bleed-off line and valve are properly sized and installed on the discharge side of the pump and connected to a convenient drain. In either case, the bleedoff valve should be fully open.

Strainer

Check the strainers, if applicable, in the basin section to make certain they are in the proper location over the pump suction, along side of the anti-vortex hood (See Figure 24).

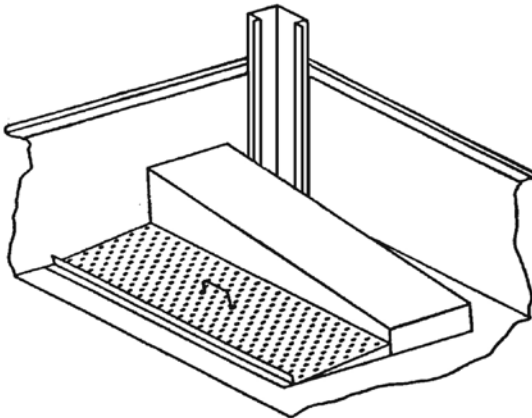

Figure 24 – Strainer Location

Screens

Protective fan screens are provided across the top of the fan cylinders of all models. Check and tighten all bolts.

WARNING!
DO NOT WALK ON THE FAN SCREENS AT ANY TIME!

Float Valve Adjustment

The float valve is pre-set at the factory; however, adjustment should be checked after rigging. The float valve should be adjusted so that the centerline of the float is 11 inches (28 cm) from the basin bottom. Raise or lower the float by using the wing nuts on the vertical threaded rod only. Do not adjust the horizontal rod.

Starting Sequence

Before starting the unit, check that all access openings, safety screens and covers are in place. Start the unit as outlined below:

1. Fill the pan to the overflow level.
2. Bump start and check the spray water pump(s) for proper rotation. Directional arrows are found on the pump impeller housing.
3. Bump start and check the fan(s) for proper rotation. Directional arrows are placed on the side of the fan cylinder.

Maintenance

Once the installation is complete and the unit is turned on, it is important that it be properly maintained. Maintenance is not difficult or time-consuming but must be done regularly to assure full performance of the unit. Refer to the maintenance instructions enclosed with the unit for proper maintenance procedures.

Freeze Protection

Proper freeze protection must be provided if the unit is located in a cold climate. Refer to maintenance instructions as well as product bulletins for further information.



Rigging Hardware Parts List

The following table lists those parts which are shipped together with the unit(s) for field assembly and/or spare parts.

C-ATC Model	C-ATW Model	C-ATWB Model	Box Size	Self Tappers ¹	Sealer Tape (Rolls)	Spare Nozzles	Assembly Hardware ²
181 to 251	67	7-*9	7'4" x 9' (2.24 x 2.7 m)	-	2	2	20
264 to 338	89	7-*12	7'4" x 12' (2.24 x 3.6 m)	-	2	2	20
329 to 373	103	7-*14	7'4" x 14' (2.24 x 4.3 m)	-	2	2	20
362 to 504	133	7-*18	7'4" x 18' (2.24 x 5.5 m)	-	2	2	32

NOTES:

1. 5/16" x 1" (M8 x 25) or 3/8 x 1" (M10 x 25) taper. Stainless units use 5/16" (M8) nuts and bolts.
2. 1/2" x 1-1/4" (M12 x 30) bolt, hex nut, lock-washer and (2) flat washers.

Table 3 – Rigging Hardware

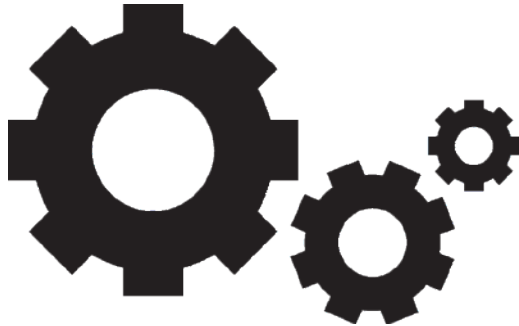

FOR EVAPCO AUTHORIZED PARTS AND SERVICE, CONTACT YOUR LOCAL EVAPCO REPRESENTATIVE OR THE LOCAL SERVICE CENTER



Mr. GoodTower®



EVAPCO, Inc. — World Headquarters & Research/Development Center

P.O. Box 1300 • Westminster, MD 21158 USA
410.756.2600 • marketing@evapco.com • evapco.com

North America

EVAPCO, Inc.
World Headquarters
Westminster, MD USA
410.756.2600
marketing@evapco.com

EVAPCO East
Taneytown, MD USA

EVAPCO East
Key Building
Taneytown, MD USA

EVAPCO Midwest
Greenup, IL USA
217.923.3431
evapcomw@evapcomw.com

Evapcold Manufacturing
Greenup, IL USA

EVAPCO Newton
Newton, IL USA
618.783.3433
evapcomw@evapcomw.com

EVAPCO West
Madera, CA USA
559.673.2207
contact@evapcowest.com

EVAPCO Alcoil, Inc.
York, PA USA
717.347.7500
info@evapco-alcoil.com

EVAPCO Iowa
Lake View, IA USA

EVAPCO Iowa
Sales & Engineering
Medford, MN USA
507.446.8005
evapcomn@evapcomn.com

EVAPCO LMP ULC
Laval, Quebec, Canada
450.629.9864
info@evapcolmp.ca

EVAPCO Select Technologies, Inc. Belmont, MI USA
844.785.9506
emarketing@evapcoselect.com

Refrigeration Vessels & Systems Corporation
Bryan, TX USA
979.778.0095
rvs@rvscorp.com

Tower Components, Inc.
Ramseur, NC USA
336.824.2102
mail@towercomponentsinc.com

EvapTech, Inc.
Edwardsville, KS USA
913.322.5165
marketing@evaptech.com

EVAPCO Dry Cooling, Inc.
Bridgewater, NJ USA
908.379.2665
info@evapcodc.com

EVAPCO Dry Cooling, Inc.
Littleton, CO USA
908.895.3236
info@evapcodc.com

EVAPCO Power México S. de R.L. de C.V.
Mexico City, Mexico
(52) 55.8421.9260
info@evapcodc.com

Asia / Pacific

EVAPCO Asia Pacific Headquarters
Baoshan Industrial Zone Shanghai, P.R. China
(86) 21.6687.7786
marketing@evapcochina.com

EVAPCO (Shanghai) Refrigeration Equipment Co., Ltd.
Baoshan Industrial Zone, Shanghai, P.R. China

EVAPCO (Beijing) Refrigeration Equipment Co., Ltd.
Huairou District, Beijing, P.R. China
(86) 10.6166.7238
marketing@evapcochina.com

EVAPCO Air Cooling Systems (Jiaxing) Company, Ltd.
Jiaxing, Zhejiang, P.R. China
(86) 573.8311.9379
info@evapcochina.com

EVAPCO Australia (Pty.) Ltd.
Riverstone, NSW, Australia
(61) 02.9627.3322
sales@evapco.com.au

EvapTech (Shanghai) Cooling Tower Co., Ltd.
Baoshan District, Shanghai, P.R. China.
Tel: (86) 21.6478.0265

EvapTech Asia Pacific Sdn. Bhd.
Puchong, Selangor, Malaysia
(60) 3.8070.7255
marketing-ap@evaptech.com

Europe | Middle East | Africa

EVAPCO Europe EMENA Headquarters
Tongerren-Borgloon, Belgium
(32) 12.39.50.29
info@evapco.be

EVAPCO Europe BV
Tongerren-Borgloon, Belgium

EVAPCO Europe, S.r.l.
Milano, Italy
(39) 02.939.9041
evapcoeuropa@evapco.it

EVAPCO Europe, S.r.l.
Sondrio, Italy

EVAPCO Europe A/S
Aabybro, Denmark
(45) 9824.4999
info@evapco.dk

EVAPCO Europe GmbH
Meerbusch, Germany
(49) 2159.69560
info@evapco.de

EVAPCO Middle East DMCC
Dubai, United Arab Emirates
(971) 56.991.6584
info@evapco.ae

Evap Egypt Engineering Industries Co.
A licensed manufacturer of EVAPCO, Inc.
Nasr City, Cairo, Egypt
(202) 10 054 32 198
evapco@tiba-group.com

EVAPCO S.A. (Pty.) Ltd.
A licensed manufacturer of EVAPCO, Inc.
Isando, South Africa
(27) 11.392.6630
evapco@evapco.co.za

South America

EVAPCO Brasil
Equipamentos Industriais Ltda.
Indaialuba, São Paulo, Brazil
(55) 11.5681.2000
vendas@evapco.com.br

FanTR Technology Resources
Itu, São Paulo, Brazil
(55) 11.4025.1670
fantr@fantr.com

TECHNOLOGY FOR THE FUTURE, AVAILABLE TODAY

Visit EVAPCO's websites: www.evapco.eu / www.mrgoodtower.eu