



# Rigging & Assembly Instructions

## PHC-E SERIES

INDUCED DRAFT  
EVAPORATIVE  
CONDENSERS



Mr. GoodTower





# Table of Contents

Method of Shipment .....	3
Storage .....	3
General .....	3
Structural Steel Support .....	3
Rigging the Basin Section .....	4
Extended Lifts .....	5
Applying Sealer Tape .....	6
Rigging Coil / Fan Section .....	6
Assembly of the Coil / Fan Section to the Basin Section .....	7
Final Assembly & Startup Details .....	8
Notes .....	10

The PHC-E SERIES INDUCED DRAFT EVAPORATIVE CONDENSERS  
 should be rigged and assembled using the instructions and  
 recommendations outlined in this bulletin.

All personnel should review these procedures, as well as the latest industry-approved installation practices, prior to rigging and assembly. The information in this bulletin is for informational purposes only. These instructions do not purport to cover all variations and possible contingencies in connection with installation. Additionally, the procedures described herein are subject to change without prior notice, due to EVAPCO, Inc.'s ongoing research and development.

EVAPCO, Inc. makes no representations or warranties with respect to these instructions or the products described herein. Nor shall EVAPCO, Inc. be responsible for any loss or damage (direct, indirect, consequential, or other) during installation or handling of equipment after shipment.

*For a full description of EVAPCO's liability policy, please visit [www.evapco.com](http://www.evapco.com) to access our Terms and Conditions.*



---

## Method of Shipment

---

PHC-E condensers are shipped with the top section(s) separate from the bottom section(s). These sections have mating flanges and will join together in a waterproof joint when sealed and bolted together as described in the following instructions. Miscellaneous items, such as sealer, fasteners and any other required materials, are packaged and placed inside the pan for shipment.

**NOTE:** All stainless steel rigging bolts should be coated with anti-seize spray on the threads to prevent nut galling.

---

## Storage

---

Do not place tarps or other coverings over the top of the units if the units are to be stored before installation. Excessive heat can build up if the units are covered causing possible damage to the PVC crossflow fill and eliminators. For extended storage, rotate the fan and fan motor shaft(s) monthly. Beyond six months, the fan shaft bearings should be purged and regreased prior to startup.

---

## General

---

**For extended lifts, or where hazards may exist, it is recommended that safety slings and spreaders be employed for safety. Refer to the "Extended Lifts" section in this bulletin.**

**NOTE:** All casing sections are factory inspected prior to shipment to verify proper fit for rigging. Please take extra care to handle and rig unit sections per the instructions of this manual to avoid possible distortion and cause poor casing alignment. It is advisable to check each section upon receipt and during each lift to ensure that the factory alignment has not been altered. Should the field inspection indicate the section alignment ("square") has been altered, please contact the factory or your local EVAPCO sales representative for additional instructions to obtain proper section fit.

---

## Structural Steel Support

---

### PHC-S-E

Two structural I-beams running the length of the unit are required for supporting the unit. These beams should be located underneath the outer flanges of the unit. (See **Figure 1**)

### PHC-D-E Models

Three structural I-beams running the width of the unit are required for supporting the unit. Locate two beams underneath the outer flanges of the unit and locate the third beam laterally along the center of the unit. (See **Figure 2**)

### All Models

Mounting holes, 3/4" (19 mm) in diameter, are located in the bottom flange for bolting to the structural steel. Refer to the recommended structural steel support drawing and certified print for exact bolt hole location. Bolt the bottom section to the steel support before rigging the top section.

Beams should be sized in accordance with accepted structural practices and the local building code regulations. Maximum deflection of the beam under the unit is recommended to be 1/360 of the unit length, not to exceed 1/2" (13 mm). Deflection may be calculated by using 55% of the operating weight as a uniform load on each beam (see certified print for operating weight).

The supporting I-beams should be level to within 1/8" (3 mm) in 6' (1.8 m) before setting the unit. Do not level the unit by shimming between the bottom unit flange and the beams as this will not provide proper longitudinal support.

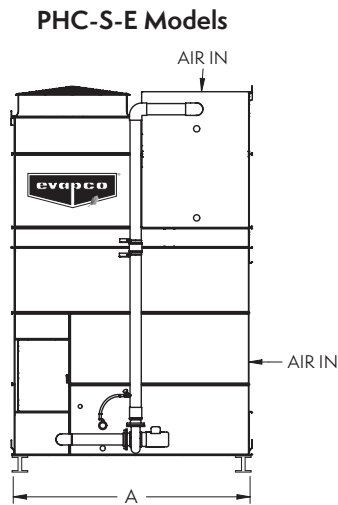

Figure 1 — Recommended Steel Support for S Models

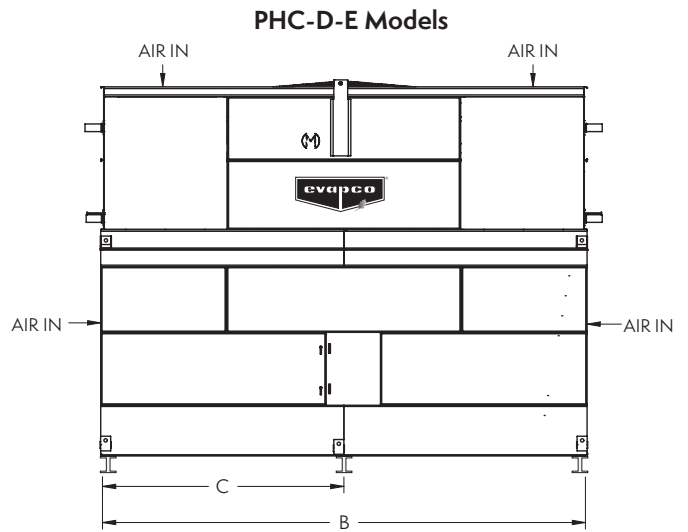

Figure 2 — Recommended Steel Support for D Models

Table 1 — Recommended Steel Support

	PHC-E Pan Footprint Dimensions			
	Box Size	A	B	C
S Models	7x9	86" (2184 mm)	-	-
	7x12	86" (2184 mm)	-	-
	7x18	86" (2184 mm)	-	-
	12x12	142" (3607 mm)	-	-
	12x18	142" (3607 mm)	-	-
	12x24	142" (3607 mm)	-	-
	12x36	142" (3607 mm)	-	-
D Models	12x24	-	288" (7315 mm)	144" (3658 mm)
	14x26	-	312" (7925 mm)	156" (3962 mm)
	24x24	-	288" (7315 mm)	144" (3658 mm)
	28x26	-	312" (7925 mm)	156" (3962 mm)

## Rigging Basin Section

Lifting devices are located in the lower corners of the basin section for lifting and final positioning purposes as shown in Figures 3 and 4. The bottom of spreader beam must be a minimum dimension of "H" above the lowest lifting ear to prevent undue strain on the lifting devices. See Table 2 for the minimum "H" dimension. These lifting devices should not be used for extended lifts or where any hazard exists unless safety slings are employed under the section. (See "Extended Lifts" section for proper arrangement.) Bolt the basin section to the steel support before rigging the coil / fan section.

Table 2 — Dimensions for Basin Sections

Section Size - Unit Type	H	W
7 x 9 - S	8' 10" (2692 mm)	7' 4" (2235 mm)
7 x 12 - S	11' 8" (3556 mm)	7' 4" (2235 mm)
7 x 18 - S	16' 11" (5156 mm)	7' 4" (2235 mm)
12 x 12 - S	11' 8" (3556 mm)	12' (3.6 m)
12 x 18 - S	16' 11" (5156 mm)	12' (3.6 m)
12 x 24 - D	10' 4" (3150 mm)	12' (3.6 m)
14 x 26 - D	11' 3" (3429 mm)	14' (4.2 m)

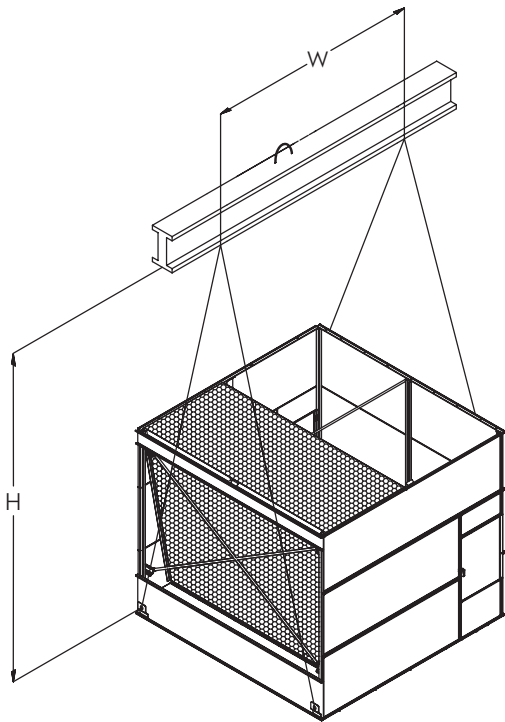

**Figure 3** — S Model Basin Section  
9' (2.7 m), 12' (3.6 m) and 18' (5.5m) Long

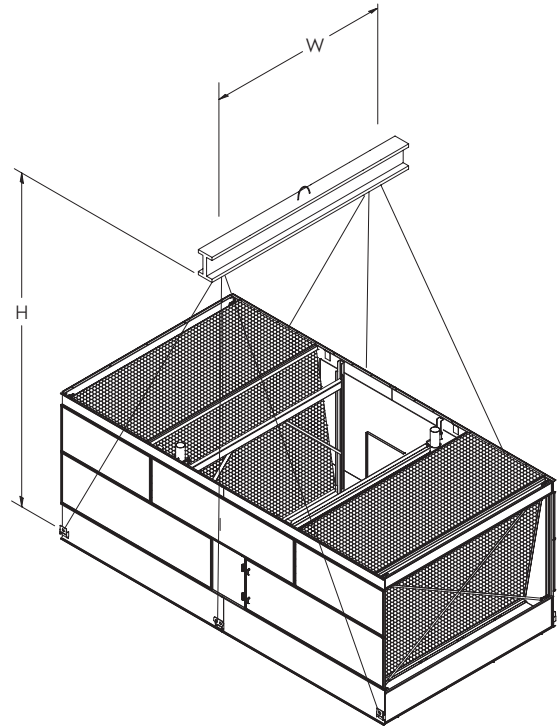

**Figure 4** — D Model Basin Section  
24' (7.3 m) and 26' (7.9 m) Long

## Extended Lifts

The recommended method for extended lifts is to use safety slings under the unit (see **Figure 5**). Spreader bars should always be used between the cables at the top of the section to prevent damage to the upper flanges.

**NOTE:** The lifting points should be used for final positioning only and for lifting where no danger exists. If they are used for extended lifts, safety slings and spreader bars should be provided under the sections as shown.

Safety slings, spreaders, and skids should be removed before final positioning of the unit.

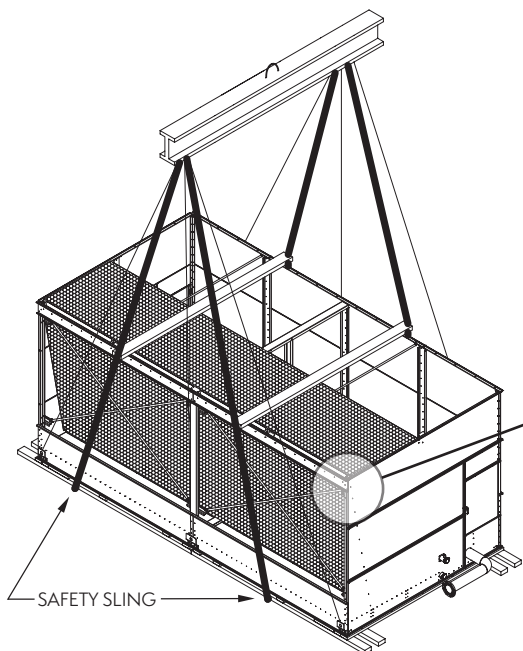

**Figure 5** — Proper Rigging Method for Extended Lifts

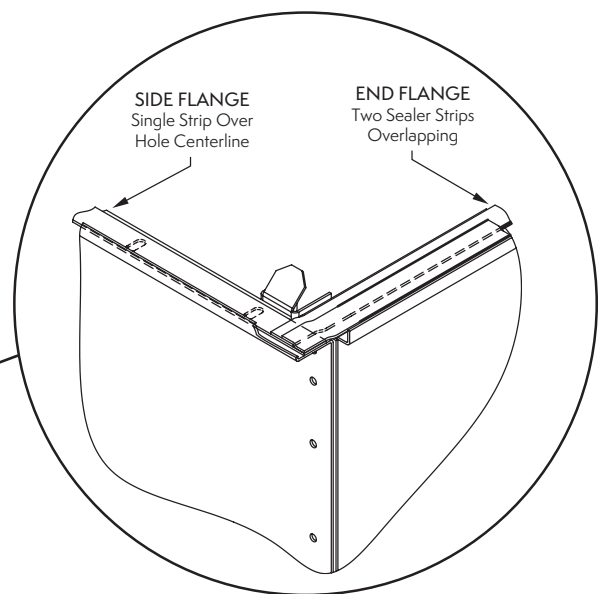

**Figure 6** — Proper Sealer Tape Application



## Applying Sealer Tape

Once the bottom section has been set on the supporting steel and bolted in place, wipe the top flanges to remove any dirt or moisture. Place sealer tape over the mounting holes centerline on the side flanges. Apply two strips of sealer tape, one partially overlapping the other, on the end flanges. The sealer tape should overlap on the corners as shown in **Figure 6**. Do not splice the sealer tape along the end flanges and preferably not on the side flanges if it can be avoided. Always remove the paper backing from the sealer tape.

## Rigging Coil / Fan Section

Four lifting ears are provided in the upper corners of the coil / fan sections for lifting. Sections 24' (7.3 m) or longer will have two additional lifting ears in the middle of the section (See **Figures 7 and 8**).



**CAUTION: USE ALL LIFTING EARS PROVIDED ON THE SECTION. A SPREADER BEAM MUST BE USED FOR LIFTING THE TOP SECTION(S) AS SHOWN IN FIGURES 7 and 8!**

The bottom of the spreader beam must be a minimum dimension "H" above the lowest lifting ear to prevent undue strain on the lifting ears and the section structure. The weight is not evenly distributed across the width of the coil/fan section. Therefore, the top connection of the spreader beam will need to be offset towards the coil side to balance the load. The location of this connection will vary based on the unit configuration. See **Table 3** for the "H" and "W" dimensions. These lifting devices should not be used for extended lifts or where any hazard exists unless safety slings are employed under the section. (See "Extended Lifts" for proper arrangement)

**Table 3** – Dimensions for Coil / Fan Sections

Section Size - Unit Type	H	W
7 x 9 - S	8' 10" (2692 mm)	7' 4" (2235 mm)
7 x 12 - S	11' 8" (3556 mm)	7' 4" (2235 mm)
7 x 18 - S	16' 11" (5156 mm)	7' 4" (2235 mm)
12 x 12 - S	11' 8" (3556 mm)	12' (3.6 m)
12 x 18 - S	16' 11" (5156 mm)	12' (3.6 m)
12 x 24 - D	10' 4" (3150 mm)	12' (3.6 m)
14 x 26 - D	11' 3" (3429 mm)	14' (4.2 m)

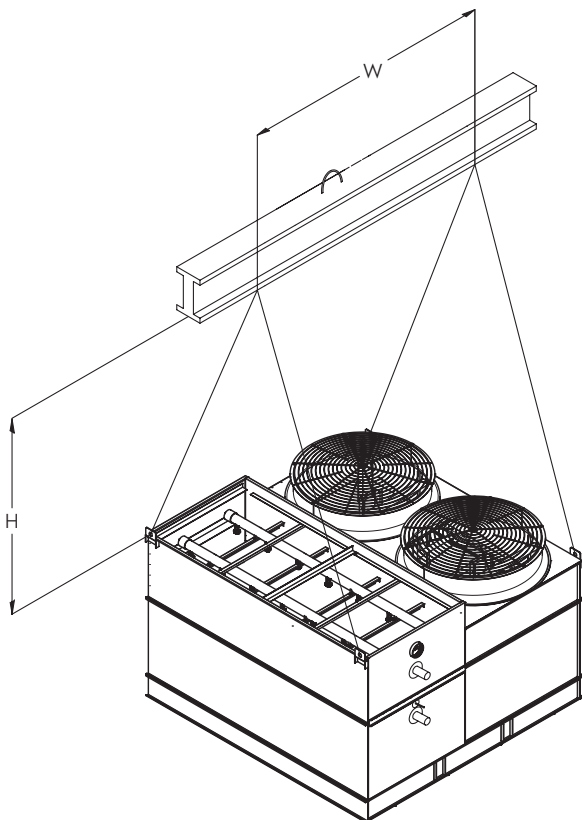

**Figure 7** – S Model Coil / Fan Section  
9' (2.7 m), 12' (3.6 m) and 18' (5.5 m) Long

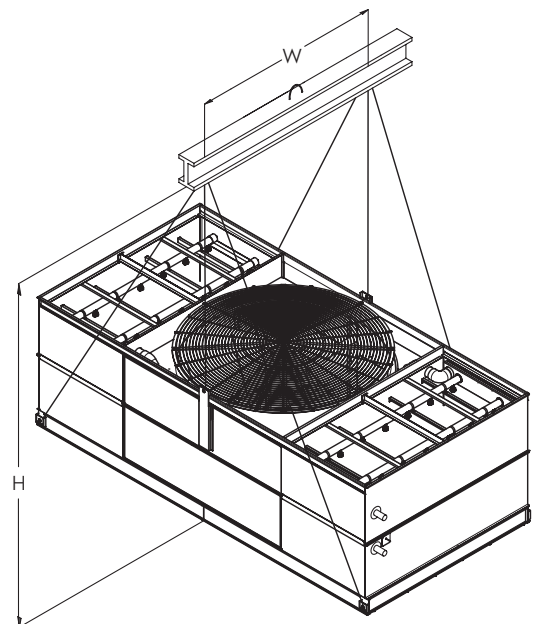

**Figure 8** – D Model Coil / Fan Section  
24' (7.3 m) and 26' (7.9 m) Long

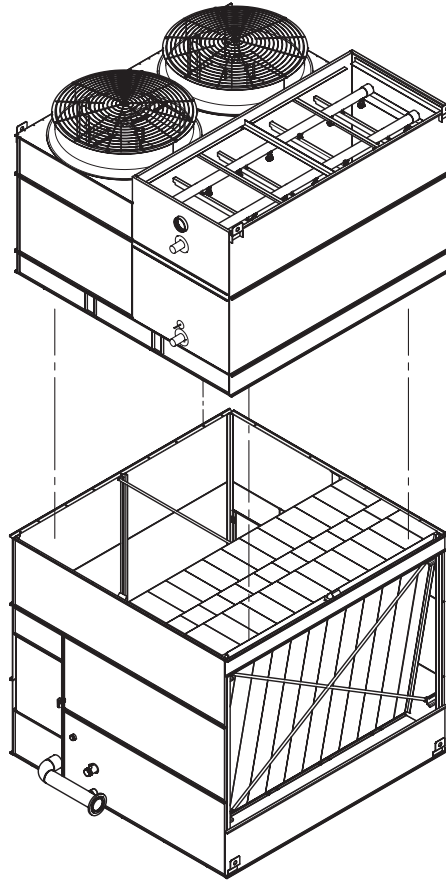

**Figure 9** – Mating Upper Coil / Fan Section to Basin Section

**NOTE:** A rigging box equipped with sealer tape and necessary fasteners is normally secured inside the pan basin for shipping. Remove the rigging box from the basin prior to assembly of sections.

## Assembly of the Coil / Fan Section to the Basin Section

Before assembling the coil / fan section to the basin section, follow instructions on “Applying Sealer Tape” on page 4 and remove any loose parts shipped in the pan.

Wipe the flanges on the bottom of the coil / fan section. Check to see that the water distribution connection on the coil / fan section is in the correct position relative to the basin section (see certified print).

Lower the coil / fan section to within several inches of the basin section making sure the two sections do not touch and the sealer tape is not disturbed. Place drift pins (see **Figure 9**) in at least three of the corner mounting holes and gradually lower the coil section into place using the drift pins to guide the section down accurately onto the mating flange. On long sections, 18’ (5.5 m) and longer, drift pins should be used midway along the sides as well.

Place fasteners in all four corner bolt holes. Then continue to install the rest of the fasteners working from the corners toward the center, using drift pins to align the holes. A fastener must be installed in every hole on the side and end flanges.

For units with two coil sections, mount the first as described, and then follow the same procedure for the second section.



### Final Assembly & Startup Details

---

#### Shipping Materials

Remove any wood chocks, spare parts, or miscellaneous items that have been placed inside the unit for shipping purposes. Clean all debris from the basin.

#### Pump Discharge Line

Connect the riser pipe from the pump discharge on the basin section to the riser pipe on the coil / fan section using the flexible connection and hose clamps provided.

#### Makeup Water Line

Connect (plumb) the makeup water source to the makeup water connection on the unit. The makeup water supply pressure to the unit should be maintained between 20 and 50 psig (140 kPa and 340 kPa). Water supply pressure in excess of 50 psig (340 kPa) may damage the mechanical float valve.

#### Bleed or Blowdown

EVAPCO recommends an automated conductivity controller to maximize the water efficiency of your system. Based on recommendations from the selected water treatment company, the conductivity controller should open and close a motorized ball or solenoid valve to maintain the conductivity of the recirculating water. If the manual valve provided in the bleed-off line on a unit with factory supplied pump(s) is used to control the rate of bleed, it should be set to maintain the conductivity of the recirculating water during periods of peak load at the maximum level recommended by the selected water treatment company. If no direction is provided, the valve should be fully open. On units shipped without a pump (remote sump applications), the bleed-off arrangement and valve must be provided by the customer.

#### Float Valve Adjustment

The float valve is preset at the factory however adjustment should be checked after rigging. The float valve should be adjusted so that the center of the float is 1" below the center of the overflow connection when the valve is in the fully closed position. Raise or lower the float by using the wing nuts on the vertical threaded rod. Do not adjust the horizontal rod.

During normal operation, the water level will drop 3" (76 mm) to 4" (102 mm) below the overflow.

#### Strainer

Check the strainer in the basin to ensure that it is in its proper location over the pump suction.

#### Screens

Protective screens are provided across the top of the fan cylinders on all models. Inspect the screens to ensure there are no gaps that may present a safety hazard. Check all screen fasteners to ensure they are tight and secure.

#### Fan Rotation

Bump start and check the fans for proper rotation. Directional arrows are placed on the inside of the axial fan cylinders.

#### Pump Rotation

After filling the basin to the overflow with fresh water, bump start and check the pump for proper rotation. Directional arrows are found on the pump impeller housing. **Do not start pumps prior to filling the basin with water. Dry pump operation will damage the pump seals.**

#### Maintenance

Once installation is complete and the unit is turned on, it is important that it be properly maintained. Maintenance is not difficult or time consuming but must be done regularly to assure maximum trouble free performance of the unit. Refer to the "Operation and Maintenance Instructions" bulletin enclosed with the unit for proper maintenance procedures.

Also, proper freeze protection must be provided if the unit is located in a cold climate. Refer to the "Operation and Maintenance Instructions" bulletin supplied as well as factory product bulletins for further information.



### Water Treatment and Passivation

Proper water treatment is an essential part of the maintenance required for evaporative cooling equipment. A well designed and consistently implemented water treatment program will help to ensure efficient system operation while maximizing the equipment's service life. A qualified water treatment company should design a site-specific water treatment protocol based on the equipment (including all metallurgies in the cooling system), location, makeup water quality, and usage.

"White rust" is a premature failure of the protective zinc layer on hot dip or mill galvanized steel which can occur as a result of improper water treatment control during the startup of new equipment. The initial commissioning and passivation period is critical for maximizing the service life of galvanized equipment. EVAPCO recommends that site-specific water treatment protocols include a passivation procedure which details water chemistry, any necessary chemical addition, and visual inspections during the first six (6) to twelve (12) weeks of operation. During this passivation period, recirculating water pH should be maintained above 7.0 and below 8.0 at all times. Since elevated temperatures have a harmful effect on the passivation process, the new galvanized equipment should be run without load for as much of the passivation period as is practical.

For more information on water treatment and water chemistry guidelines, refer to the "Operation and Maintenance Instructions" bulletin supplied.





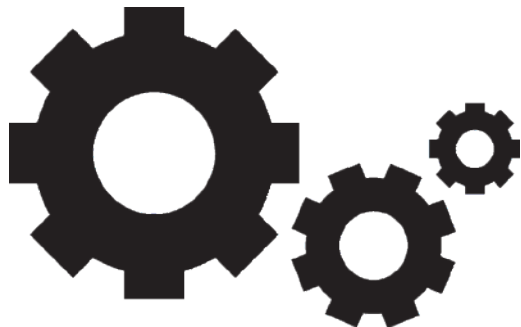

FOR EVAPCO AUTHORIZED PARTS AND SERVICE, CONTACT YOUR LOCAL EVAPCO REPRESENTATIVE OR THE LOCAL SERVICE CENTER



Mr. GoodTower®



EVAPCO, Inc. — World Headquarters & Research/Development Center

P.O. Box 1300 • Westminster, MD 21158 USA  
410.756.2600 • marketing@evapco.com • evapco.com

North America

**EVAPCO, Inc.**  
World Headquarters  
Westminster, MD USA  
410.756.2600  
marketing@evapco.com

**EVAPCO East**  
Taneytown, MD USA

**EVAPCO East**  
Key Building  
Taneytown, MD USA

**EVAPCO Midwest**  
Greenup, IL USA  
217.923.3431  
evapcomw@evapcomw.com

**Evapcold Manufacturing**  
Greenup, IL USA

**EVAPCO Newton**  
Newton, IL USA  
618.783.3433  
evapcomw@evapcomw.com

**EVAPCO West**  
Madera, CA USA  
559.673.2207  
contact@evapcowest.com

**EVAPCO Alcoil, Inc.**  
York, PA USA  
717.347.7500  
info@evapco-alcoil.com

**EVAPCO Iowa**  
Lake View, IA USA

**EVAPCO Iowa**  
Sales & Engineering  
Medford, MN USA  
507.446.8005  
evapcomn@evapcomn.com

**EVAPCO LMP ULC**  
Laval, Quebec, Canada  
450.629.9864  
info@evapcolmp.ca

**EVAPCO Select Technologies, Inc.** Bel-  
mont, MI USA  
844.785.9506  
emarketing@evapcoselect.com

**Refrigeration Vessels &  
Systems Corporation**  
Bryan, TX USA  
979.778.0095  
rvs@rvscorp.com

**Tower Components, Inc.**  
Ramseur, NC USA  
336.824.2102  
mail@towercomponentsinc.com

**EvapTech, Inc.**  
Edwardsville, KS USA  
913.322.5165  
marketing@evaptech.com

**EVAPCO Dry Cooling, Inc.**  
Bridgewater, NJ USA  
908.379.2665  
info@evapcodc.com

**EVAPCO Dry Cooling, Inc.**  
Littleton, CO USA  
908.895.3236  
info@evapcodc.com

**EVAPCO Power México S. de R.L. de C.V.**  
Mexico City, Mexico  
(52) 55.8421.9260  
info@evapcodc.com

Asia / Pacific

**EVAPCO Asia Pacific  
Headquarters**  
Baoshan Industrial Zone Shanghai, P.R. China  
(86) 21.6687.7786  
marketing@evapcochina.com

**EVAPCO (Shanghai)  
Refrigeration Equipment Co., Ltd.**  
Baoshan Industrial Zone, Shanghai, P.R. China

**EVAPCO (Beijing)  
Refrigeration Equipment Co., Ltd.**  
Huairou District, Beijing, P.R. China  
(86) 10.6166.7238  
marketing@evapcochina.com

**EVAPCO Air Cooling Systems  
(Jiaxing) Company, Ltd.**  
Jiaxing, Zhejiang, P.R. China  
(86) 573.831.9379  
info@evapcochina.com

**EVAPCO Australia (Pty.) Ltd.**  
Riverstone, NSW, Australia  
(61) 02.9627.3322  
sales@evapco.com.au

**EvapTech (Shanghai)  
Cooling Tower Co., Ltd.**  
Baoshan District, Shanghai, P.R. China.  
Tel: (86) 21.6478.0265

**EvapTech Asia Pacific Sdn. Bhd.**  
Puchong, Selangor, Malaysia  
(60) 3.8070.7255  
marketing-ap@evaptech.com

Europe | Middle East | Africa

**EVAPCO Europe  
EMENA Headquarters**  
Tongeren-Borgloon, Belgium  
(32) 12.39.50.29  
info@evapco.be

**EVAPCO Europe BV**  
Tongeren-Borgloon, Belgium

**EVAPCO Europe, S.r.l.**  
Milano, Italy  
(39) 02.939.9041  
evapcoeuropa@evapco.it

**EVAPCO Europe, S.r.l.**  
Sondrio, Italy

**EVAPCO Europe A/S**  
Aabybro, Denmark  
(45) 9824.4999  
info@evapco.dk

**EVAPCO Europe GmbH**  
Meerbusch, Germany  
(49) 2159.69560  
info@evapco.de

**EVAPCO Middle East DMCC**  
Dubai, United Arab Emirates  
(971) 56.991.6584  
info@evapco.ae

**Evap Egypt Engineering Industries Co.**  
A licensed manufacturer of EVAPCO, Inc.  
Nasr City, Cairo, Egypt  
(202) 10 054 32 198  
evapco@tiba-group.com

**EVAPCO S.A. (Pty.) Ltd.**  
A licensed manufacturer of EVAPCO, Inc.  
Isando, South Africa  
(27) 11.392.6630  
evapco@evapco.co.za

South America

**EVAPCO Brasil**  
Equipamentos Industriais Ltda.  
Indaiatuba, São Paulo, Brazil  
(55) 11.5681.2000  
vendas@evapco.com.br

**FanTR Technology Resources**  
Itu, São Paulo, Brazil  
(55) 11.4025.1670  
fantr@fantr.com

TECHNOLOGY FOR THE FUTURE, AVAILABLE TODAY

Visit us at: [www.evapco.eu](http://www.evapco.eu) / [www.mrgoodtower.eu](http://www.mrgoodtower.eu)