



Rigging & Assembly Instructions

**ATC-E, ATC-ES,
eco-ATC-A, ATWB,
eco-ATWB &
eco-ATWB-E**

EVAPORATIVE CONDENSERS
AND CLOSED CIRCUIT COOLERS



Mr. GoodTower

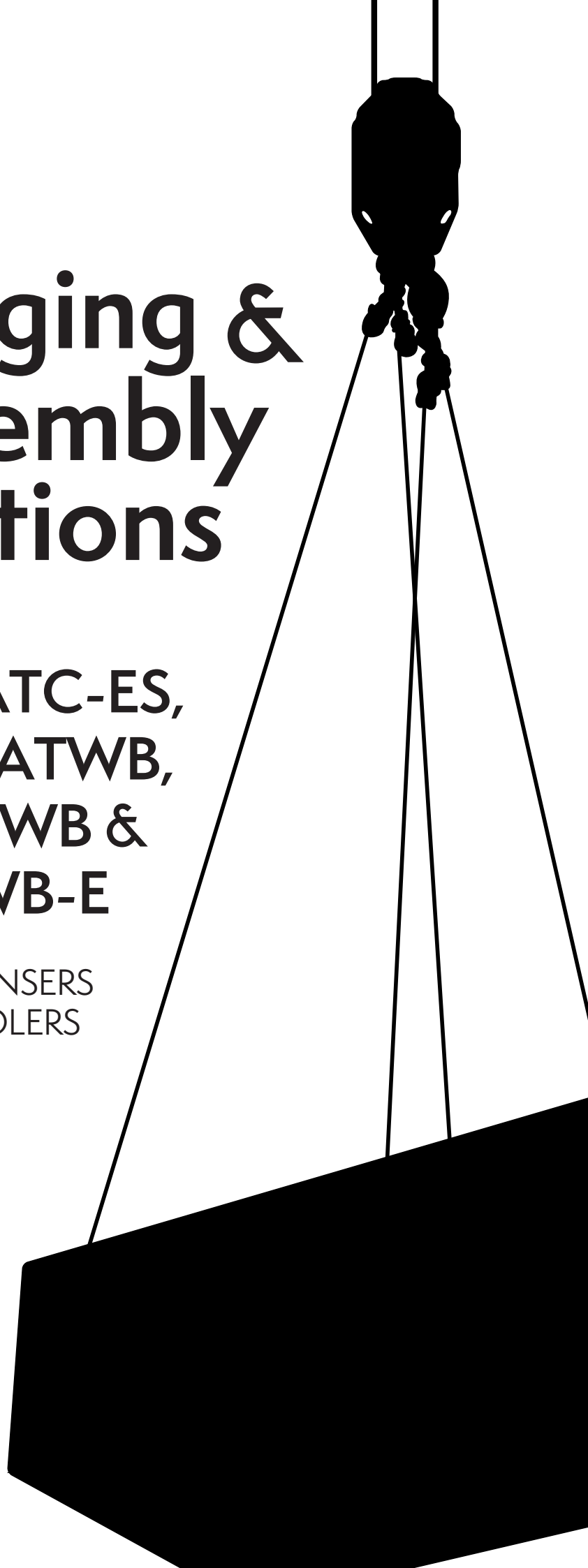



Table of Contents

Introduction	3
Method of Shipment.....	3
Structural Steel Support.....	3
Rigging Basin Sections	4
Joining Multi-Cell Units	4
Equalizer Blank-Off Plate: Multi-Cell Units.....	7
Application of Sealer Tape	7
Rigging Coil/Fan Section.....	8
Extended Lifts.....	9
Assembly of the Coil/Fan Section to the Basin	9
Containerized Unit Assembly.....	11
Assembly of the Fan Section to the Coil Section (Containerized).....	14
Assembly of the Coil Section to the Basin (Containerized).....	14
Installing Watertight Partitions & Firewalls	15
External Motor Installation — Belt Drive	16
Optional Motor & Gear Box Davit Installation.....	17
Mounting Fan Screens	17
Sloped Ladder Installation.....	18
External Platform and Vertical Ladder Installation	20
Optional Discharge Hood Damper Section Assembly - ATW Models	21
Notes	22

The ATC-E, ATC-ES, eco-ATC-A, ATWB, eco-ATWB, AND eco-ATWB-E EVAPORATIVE CONDENSERS AND CLOSED CIRCUIT COOLERS should be rigged and assembled using the instructions and recommendations outlined in this bulletin.

All personnel should review these procedures, as well as the latest industry-approved installation practices, prior to rigging and assembly. The information in this bulletin is for informational purposes only. These instructions do not purport to cover all variations and possible contingencies in connection with installation. Additionally, the procedures described herein are subject to change without prior notice, due to EVAPCO, Inc.'s ongoing research and development.

EVAPCO, Inc. makes no representations or warranties with respect to these instructions or the products described herein. Nor shall EVAPCO, Inc. be responsible for any loss or damage (direct, indirect, consequential, or other) during installation or handling of equipment after shipment.

For a full description of EVAPCO's liability policy, please visit www.evapco.com to access our Terms and Conditions.



Introduction

This manual provides instructions and recommendations to safely and correctly install all ATC-E, ATC-ES, eco-ATC-A, ATWB, eco-ATWB, and ecoATWB-E evaporative condensers and closed circuit coolers. It is recommended that all the instructions provided in this manual be reviewed in detail prior to rigging and assembly. If at any point, specific circumstances not covered by this manual arise, please contact your local EVAPCO representative for assistance.

Proper care must be taken by all parties involved in handling and assembling the equipment to ensure that safe and thorough installation practices are implemented to prevent damage or injury to the equipment, persons, and environment involved.

Method of Shipment

Induced draft coil products are shipped with the top section(s) separate from the bottom section(s). These sections have mating flanges and will join together in a waterproof joint when sealed and bolted together as described in the following instructions. Miscellaneous items, such as sealer, self-tapping screws and any other required materials, are packaged and placed inside the pan for shipment. For units consisting of multiple cells, drip channels and splash guards will ship loose in the basin for field installation.

For 7' and 8.5' (2.2 and 2.6 m) and 14' and 17' (4.3 and 5.2 m) wide units, the motors and drives are factory aligned and then shipped loose inside the basin section for mounting during installation. Refer to the "External Motor Installation" section in this bulletin.

NOTES:

All stainless steel rigging bolts should be coated with anti-seize spray on the threads to prevent nut galling.

All casing sections are factory inspected prior to shipment to verify proper fit for rigging. Please take extra care to handle and rig unit section per the instructions of this manual to avoid possible distortion and poor casing alignment. It is advisable to check each section upon receipt and during each lift to ensure that the factory alignment has not been altered. Should the field inspection indicate the section alignment ("square") has been altered, please contact the factory or your local EVAPCO representative for additional instructions to obtain proper section fit.

Structural Steel Support

Two structural I-beams running the length of the unit are required for support of each cell of the units. These beams should be located underneath the outer flanges of the unit (See Table 1). Mounting holes 3/4" (19 mm) in diameter are located in the bottom flanges of the unit for bolting to the structural steel (See steel support print in unit submittal for exact bolt hole location). Bolt the bottom section to the steel support before rigging the top section.

Beams should be sized in accordance with accepted structural practices. Maximum deflection of the beam under the unit to be 1/360th of the unit length, not to exceed 1/2" (13 mm). Deflection may be calculated by using 55% of the operating weight of the unit as a uniform load on each beam (See certified print in unit submittal for operating weight).

The supporting I-beams should be level before setting the unit. Do not level the unit by shimming between the bottom flanges and the beams as this will not provide proper and continuous longitudinal support. Support beams and anchor bolts are to be furnished by others. Always refer to the certified print in the unit submittal for unit weights, dimensions and technical data.

Please refer to the unit submittal for detailed, project specific steel support arrangement.

<p>3' (0.914 m), 4' (1.2 m), 7' (2.2 m), 8.5' (2.6 m), 10' (3 m), and 12' (3.6 m) wide single & multi-cell units</p>	
<p>14' (4.3 m), 16' (4.8 m), 17' (5.2 m), 20' (6 m) and 24' (7.3 m) wide multi-cell units</p>	

Table 1 — Standard Longitudinal Steel Support Arrangement

Rigging Basin Section

Lifting devices are located in the bottom corners of the basin (Figure 1a). Additional lifting points can be found in the middle for basins with a length of 24' (7.3 m) and over (Figure 1b). The hook of the crane must be a minimum dimension of "H" above the top of the section being lifted to prevent undue strain on the lifting devices. See Table 2 for the minimum "H" dimension. These lifting devices should not be used for extended lifts or where any hazard exists unless safety slings are employed under the section. (See "Extended Lifts" section for proper arrangement.) Bolt the basin section to the steel support before rigging the coil/fan section.

BASIN SECTION LENGTH		MINIMUM "H" DIMENSION	
FEET	METERS	FEET	METERS
3 - 6	0.9-1.8	8	2.4
8.5	2.6	10	3
9	2.7	10	3
10.5	3.2	11	3.4
12	3.6	15	4.6
14	4.3	17	5.2
18	5.5	19	5.8
20	6	21	6.4
21	6.4	22	6.7
24	7.3	15	4.6
28	8.5	16	4.9
36	11	19	5.8
40	12.2	21	6.4

Table 2 — Minimum "H" Dimensions for Basin Sections

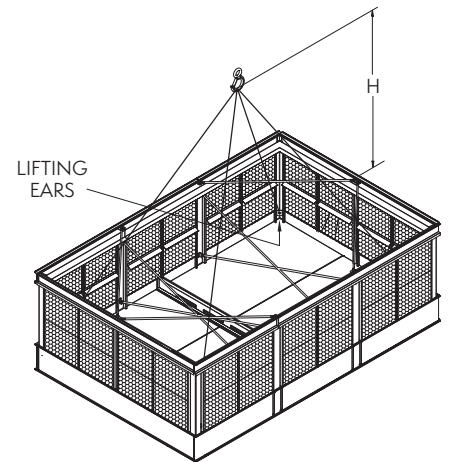

Figure 1a — Basin Section up to 21' (6.4 m) Long

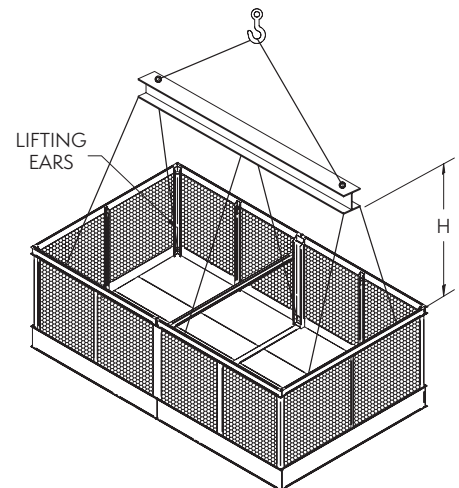

Figure 1b — Basin Section 24' (7.3 m) to 40' (12.2 m) Long

Joining Multi-Cell Units

On all two-cell models, the two bottom sections are shipped separately and are typically furnished with a connecting equalizer flume box between them.

In addition to the equalizer flumes, these units are provided with horizontal drip channels and vertical splash guards to keep water from splashing out from between the cells. All units have one or more horizontal drip channel and two vertical splash guards per flume box. Flume boxes are a standard offering on multi-cell units.

The equalizer flume box is factory installed on one section for field connection to the other. It is important to connect the equalizer flume to balance the water level in the pans for proper pump suction operation. The procedures that follow should be performed in sequence.

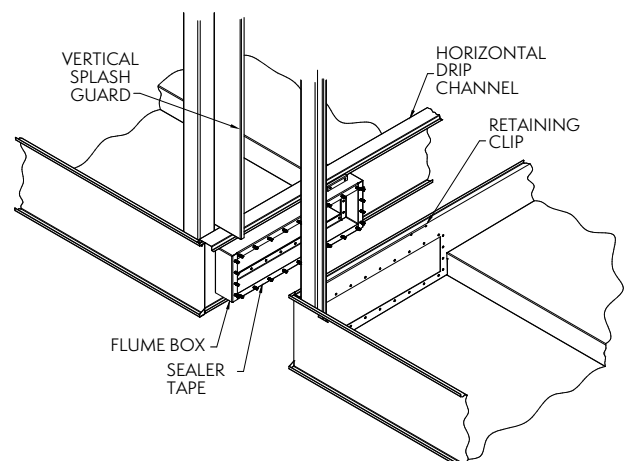

Figure 2 — Equalizer Flume Connection, 12' (3.6 m) Wide Models



For units on which the flume box ships loose:

1. Rig one of the bottom sections of the multi-cell unit. Bolt to steel support.
2. One face of the flume box is provided with 3/8" (10 mm) welded bolts. Clean the mating flume opening on the rigged bottom section and apply a layer of sealer tape on this surface, centered between the hole centers and the outside edge. Remove paper backing strip from sealer tape.
3. Align the bolt holes in the rigged bottom section with the welded 3/8" (10 mm) bolts on the flume box.
4. Install 3/8" (10 mm) nuts and washers on every bolt around the flume opening and tighten.
5. Follow steps 4 through 10 as shown below.

For units on which the flume box ships mounted to one cell:

1. Install the bottom section with the factory installed flume box on it as described above.
2. Clean the flanges on the flume box on the end to be field connected. Apply a layer of sealer tape on the flange, centered between the hole centers and the outside edge. Remove paper backing strip from the sealer tape.
3. Clean the mating surface of the flume opening of any dirt, grease or moisture.
4. Rig the second bottom section adjacent to the equalizer flume on the steel support as shown in the sequential figures that follow.
5. Align the bolt holes in the flume box and flume opening with drift pins (by others) while drawing the second bottom section against the flanged connection.
6. Install 3/8" (10 mm) bolts, nuts, and washers in every hole around the flume opening and tighten.
7. Bolt the second bottom section to the steel support.
8. Remove the 1/4" (6 mm) bolts which hold the drip channel retaining clips to the end panel. Place the drip channel over the adjoining pan section flanges. Turn around the retaining clips and install them using the same hardware.
9. If there are multiple drip channels, fasten them together end-to-end by driving a self-tapping 5/16" (8 mm) screw through the section end with the larger hole into the mating end with the smaller hole. Stainless steel units will use 5/16" (8 mm) stainless steel nuts and bolts.
10. Place the vertical splash guard in the bend of the vertical supports. On galvanized units, attach the vertical splash guard using 5/16" (8 mm) self-tapping screws. On stainless steel units, attach the vertical splash guards using 5/16" (8 mm) stainless steel nuts and bolts. (See figure 3a)
11. Once the bottom of the vertical splash guard has been attached to the drip channel, place the filler cap channel in the upper flanges of the bottom section as shown in Figure 3a. Attach to vertical splash guards using 5/16" (8 mm) tappers (for galvanized units) or stainless steel nuts and bolts (for stainless steel units)

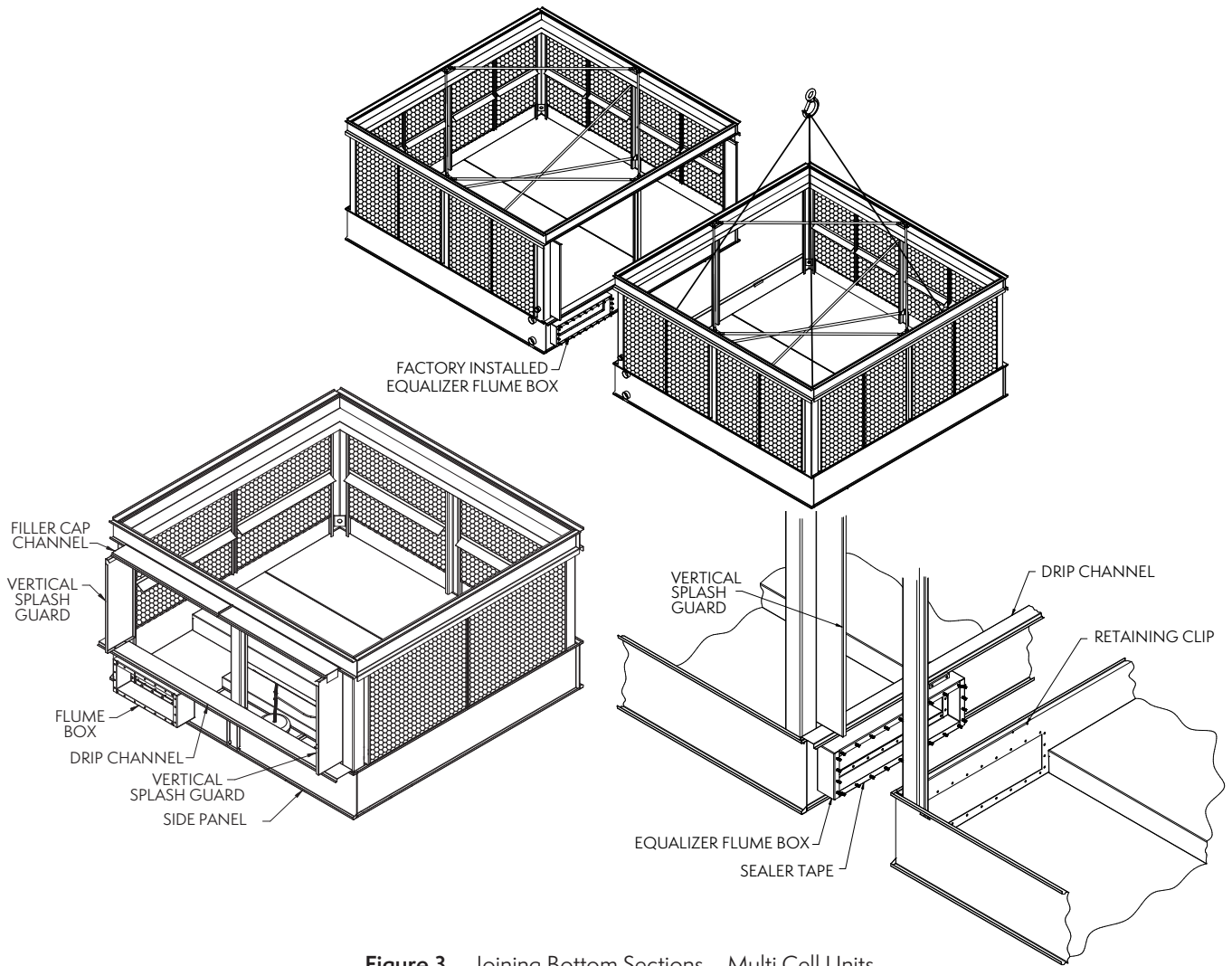

Figure 3 — Joining Bottom Sections – Multi Cell Units

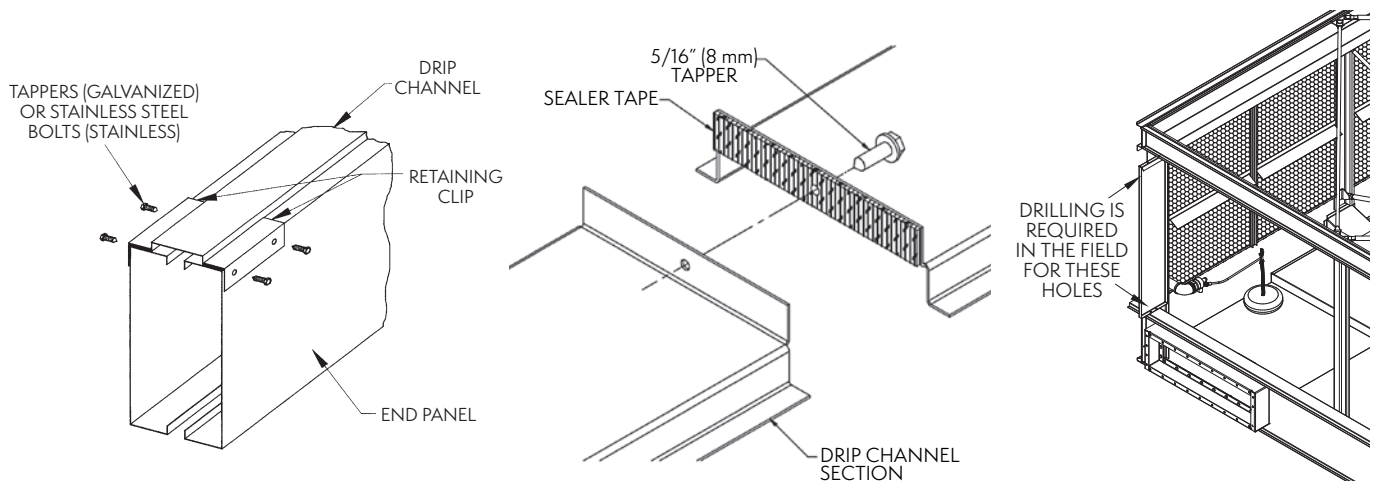

Figure 3a — Drip Channel and Vertical Splash Guard Installation

Equalizer Blank-Off Plate: Multi Cell Units

Equalizer blank-off plate(s) are available to isolate the bottom sections for individual cell operation, periodic cleaning, or maintenance. The optional equalizer blank-off plate is factory installed on the equalizer flume and secured by wing nuts. This plate is also known as a “flume plate” or “positive closure plate.”

For units not requiring the blank-off plate under normal operating conditions, remove the wing nuts, washers, plate and gasket. Reinstall washers and wing nuts for proper leak free operation of the equalizer flume box.

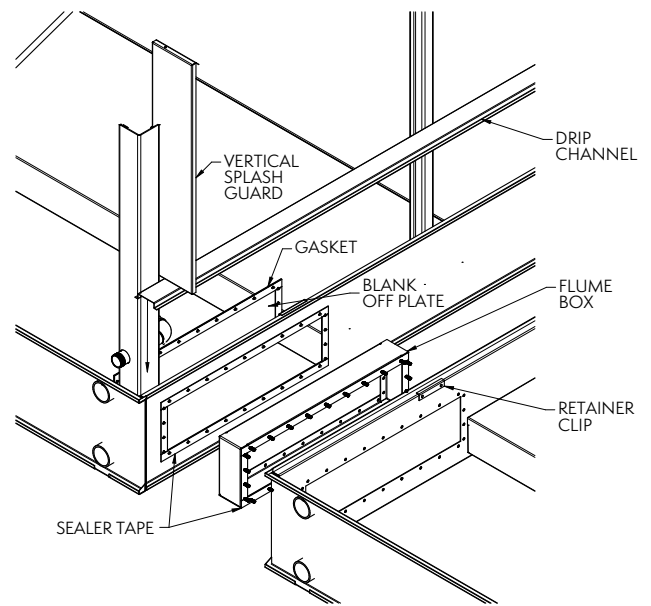

Figure 4 — Equalizer Blank-Off Plate Installation

Application of Sealer Tape

Once the bottom section has been set on the supporting steel and bolted in place, the top flanges should be wiped down to remove any dirt or moisture. Sealer tape should be placed over the mounting hole centerline on the side flanges along the entire length of all sides. Apply two strips of sealer tape, one partially overlapping the other, on the entire length of the end flanges (flanges with no bolt holes).

The sealer tape **should overlap on the corners** as shown in Figure 5a. Do not splice the sealer tape along the end flanges and preferably not on the side flanges if it can be avoided.

Always remove the paper backing from the sealer tape.

All models with two or more top sections must have sealer tape applied along the entire length of all internal flanges, as shown in Figure 5b.

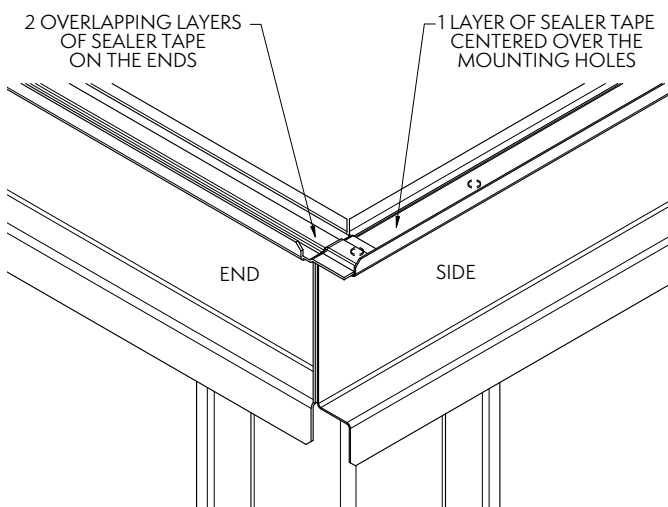

Figure 5a — Sealer Tape on Flange of Bottom Section

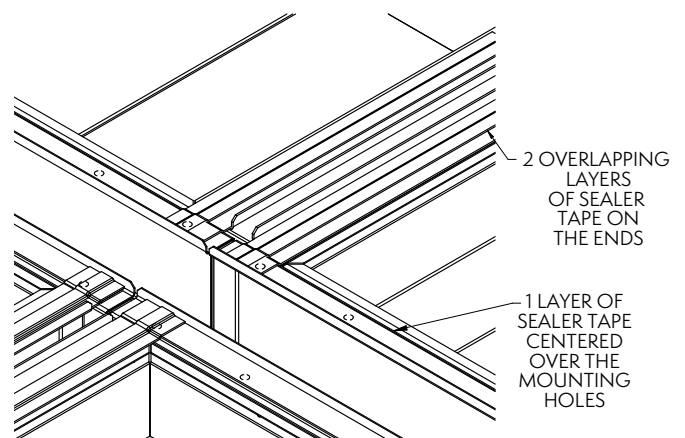

Figure 5b — Sealer Tape Detail for Center Joint of Units with Four Top Sections



Rigging Coil/Fan Section

Four lifting ears are provided in the lower corners of most coil/fan sections for lifting into final position. Some 18' (5.5 m) long sections and longer will have two additional lifting ears in the middle of the section. (See Figures 6a and 6b.)

Use all lifting ears. A spreader beam must be used for lifting the top section(s) as shown in Figures 6a and 6b.

The hook of the crane must be a minimum dimension "H" above the lifting ear to prevent undue strain on the lifting ears. See Table 3 for the minimum "H" dimension. These lifting devices should not be used for extended lifts or where any hazard exists unless safety slings are employed under the section. (See "Extended Lifts" for proper arrangement.)

NOTE:

For 7' (2.24 m) and 8.5' (2.6 m) wide models, mount the external motor prior to rigging as detailed in the "External Motor Installation" section.

Section Width		Section Length		Minimum "H" Dimension	
Feet	Meters	Feet	Meters	Feet	Meters
4	1.2	4	1.2	5	1.5
		6	1.8	6	1.8
		9	2.7	8	2.4
		12	3.6	11	3.4
6	1.8	8.5	2.6	9	2.7
7	2.24	9	2.7	9	2.7
		12	3.6	10	3
		18	5.5	14	4.3
8/8.5	2.4/2.6	6	1.8	7	2.1
		7.5	2.4	8	2.4
		9	2.7	9	2.7
		10.5	3.2	10	3
		12	3.6	10	3
		14	4.3	12	3.6
		18	5.5	14	4.3
10	3	21	6.4	17	5.2
		12	3.6	12	3.6
12	3.6	18	5.5	14	4.3
		12	3.6	12	3.6
		14	4.3	13	4
		18	5.5	14	4.3
14	4.3	20	6	15	4.6
		24	7.3	17	5.2
		26	7.8	22	6.7

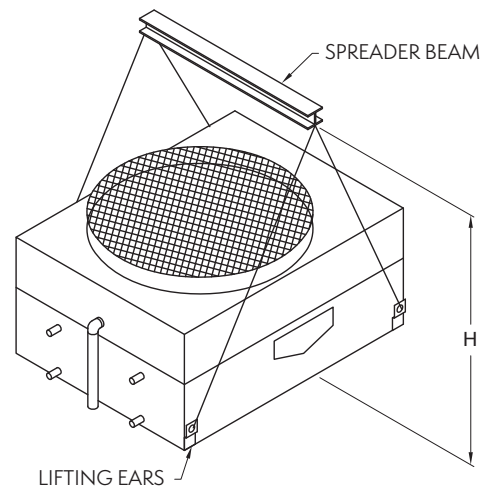

Figure 6a — Four Point Lift

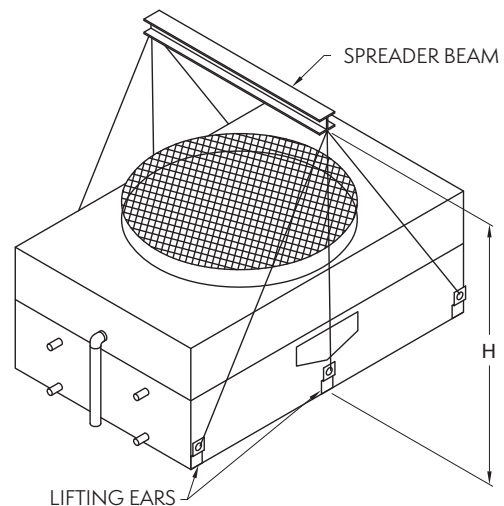

Figure 6b — Six Point Lift

Table 3 — Minimum "H" Dimension for Coil/Fan Sections

Extended Lifts

Important: The lifting devices and “U” bolts should be used for final positioning only and for lifting where no danger exists. If they are used for extended lifts, safety slings should be provided under the sections.

Safety slings and skids must be removed before final positioning of the unit.

The preferred method for extended lifts is to use slings under the unit, as shown in Figure 7 below. Spreader bars should always be used between the cables at the top of the section to prevent damage to the upper flanges or fan cylinders.

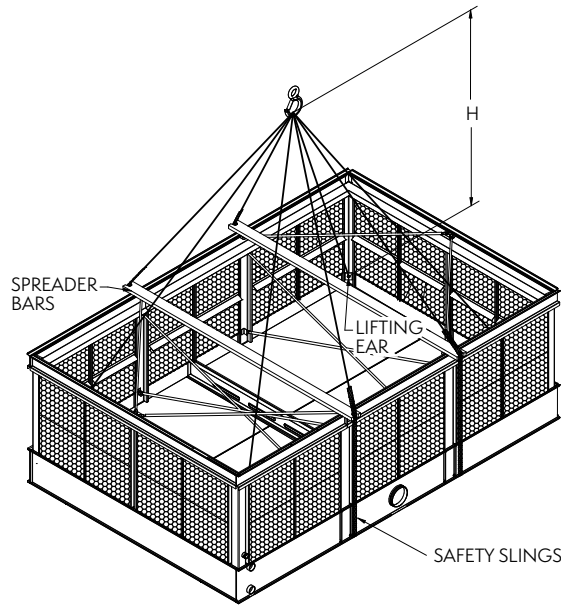

Figure 7 - Extended Lifts

Assembly of the Coil/Fan Section to the Basin

Before securing the upper section to the bottom section, remove any loose parts shipped in the basin.

Wipe the flanges on the bottom of the upper section. Check to see that the water distribution connection on the top section is in the correct position relative to the bottom section (see unit certified drawing). Units are also provided with match markings on each section (i.e. A1 of bottom section should match up with A1 of top section).

Lower the upper section to within several inches of the bottom section making sure the two sections do not touch and the sealer tape is not disturbed. Fasten all four corners. Make use of drift pins to simplify the fastening process, for further instructions on the use of drift pins, see page 10.

Install the remaining fasteners, working from the corners towards the center. Fasteners must be installed in every hole in the side flanges. No fasteners are required on the end flanges

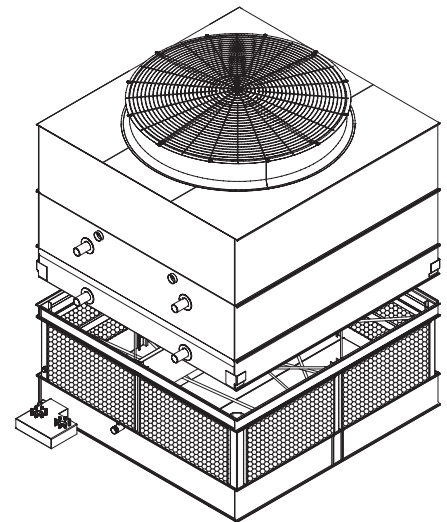

Figure 8 - Mating Upper Section to Basin Section

Assembly of the Coil/Fan Section to the Basin (Cont.)

Use of Drift Pins for Final Positioning

Drift pins are tools used to align holes in the flanges of the upper and lower sections of the unit prior to final fastening. By the time drift pins are needed, the lower section of the unit has already been anchored to its support structure. The sealer tape has been laid and the upper section is now hovering over the lower section.

A drift pin should be driven in to each of the corner bolt holes possible with sideways motion restricted.

On units which are longer than 12' ("L" > 12' [3.7 m]), a drift pin should be used at an intermediate pair of bolt holes in the rigging seam to allow for proper alignment.

NOTES:

For multi-cell units, the side flanges located in between cells can be accessed from inside the unit.

Bolts can be driven upward through the mating flanges if access is restricted.

All rigging hardware is provided by EVAPCO. Drift pins are provided by others.

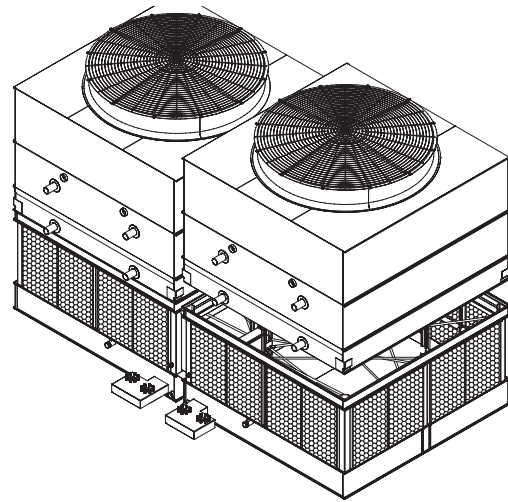

Figure 9 — Mating Upper Section to Basin Section

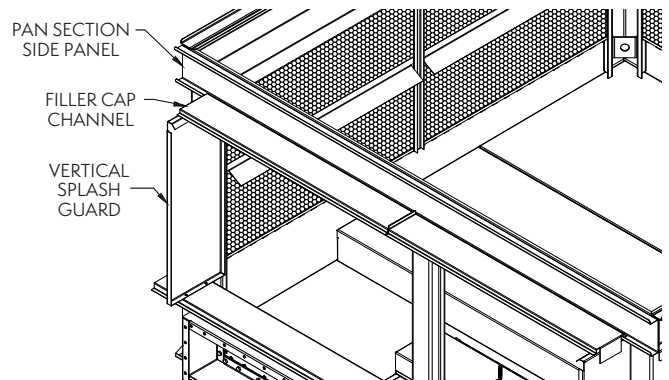

Figure 10 — Filler Cap Channel Assembly



Containerized Unit Assembly

7' and 14' (2.2 m and 4.4 m) wide ATWB units are optimized to be transported in export containers for overseas shipment. When these units are required to be shipped in containers, the fan section is loosely bolted to the basin section prior to placing in the container.

Depending on the size of the unit and accessory options, there are a few different shipping configurations as outlined below.

Unit Type	Box Size	# of Containers Required	
		Standard Fan	SLSF
Single Cell	7 x 9	(1) 20'	(1) 40'
	7 x 12	(1) 40' HC*	(1) 40'
	7 x 18	(1) 40' HC*	(1) 40' + (1) 20'
Multi-Cell	14 x 9	(1) 40' HC*	(2) 40'
	14 x 12	(1) 40' HC + (1) 20'	(2) 40'
	14 x 18	(2) 40' HC*	(3) 40'
Multi-Cell	7 x 24	(1) 40' HC + (1) 20'	(2) 40'
	7 x 36	(2) 40' HC*	(3) 40'

Table 4 – Number of Containers Required

NOTES:

* HC indicates "High Cube." High cube containers provide an additional foot of container height which allows for standard fan cylinders to ship mounted to the fan sections (See Figure 11 for an example of a high cube container).

Figure 11 below shows an example of a 7' x 18' unit shipping in a 40' high cube container. A high cube container is used so that the fan cylinders can ship mounted to the fan section. In such a case, the fan section is loosely bolted to the basin section.

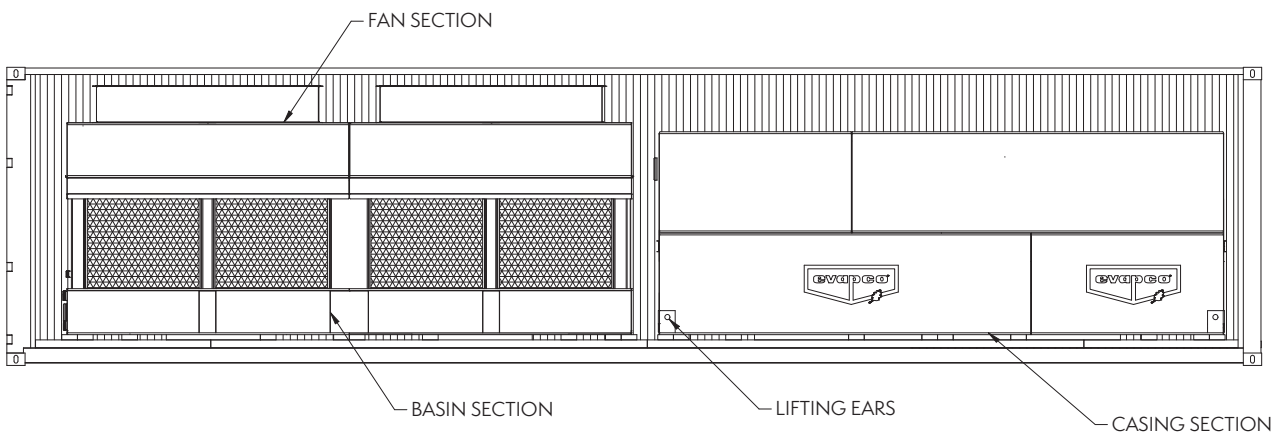

Figure 11 – 40' High Cube Container Shipment



Figure 12 shows a 7' x 9' unit shipping in a 20' standard height container. 20' containers are not available in high cube configuration, therefore fan cylinders are required to ship loose and be assembled in the field.

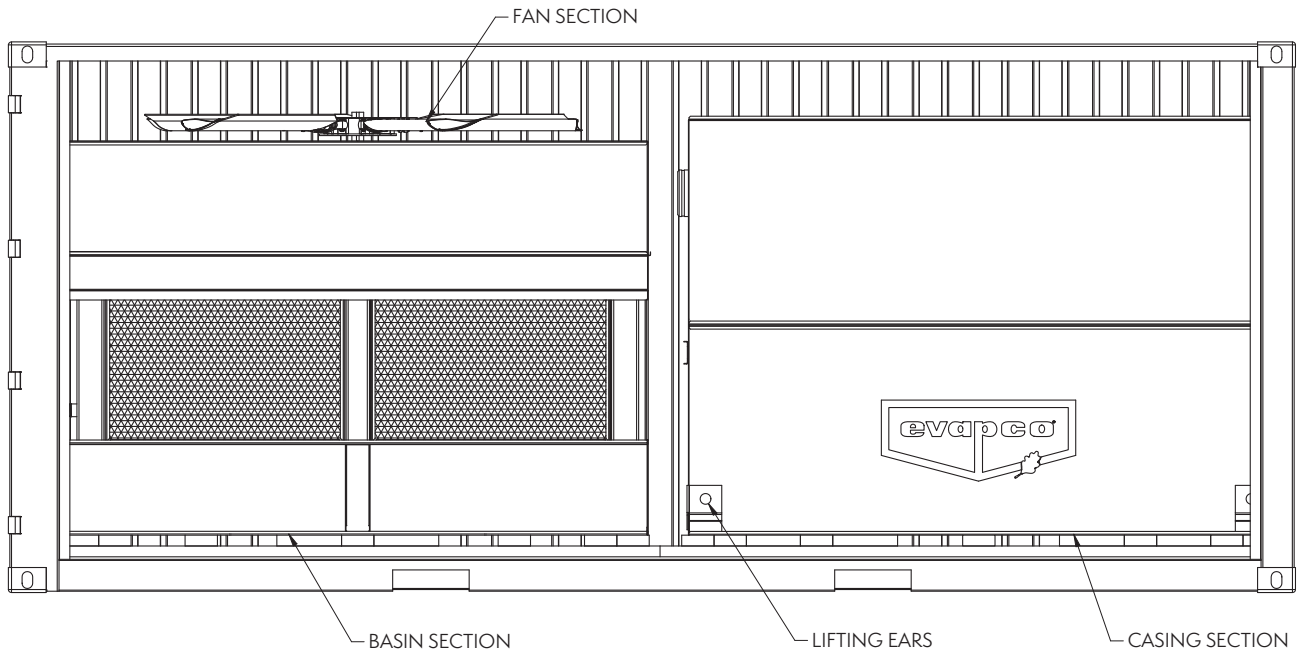

Figure 12 – 20' Standard Height Container Shipment

Instructions to put together fan cylinder:

1. Line up match-markings on the fan deck to ensure proper alignment.
2. Make sure fan assembly is centered within cylinder before attaching to fan section.

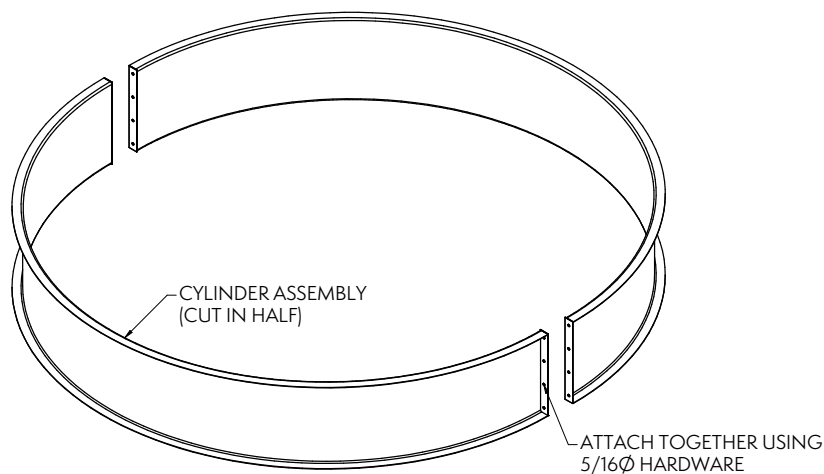

Figure 13 – Split Fan Cylinder for Standard Height Container Shipment



Figure 14 shows a 7' x 12' unit with super low sound fan shipping in a 40' standard height shipping container. Any containerized unit selected with Super Low Sound Fans will ship in 3 pieces as shown below.

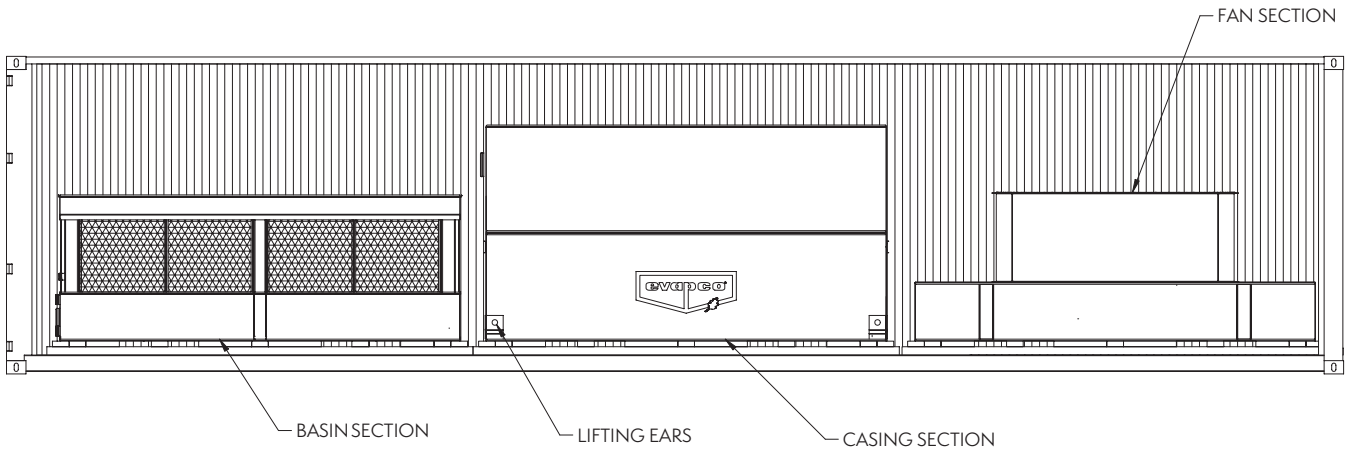
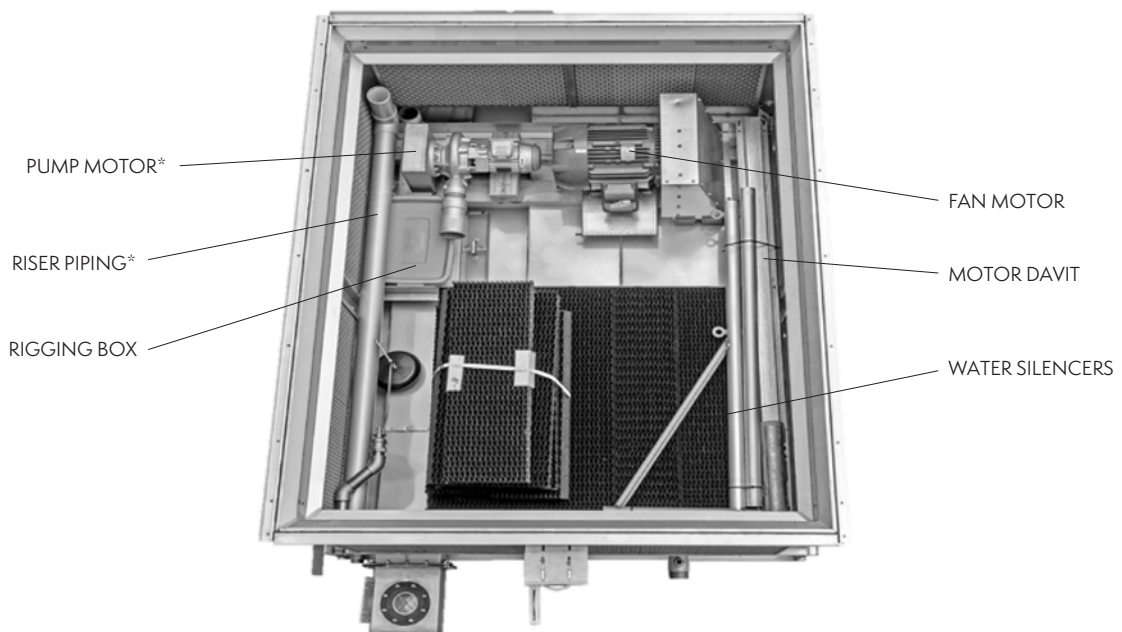

Figure 14 – 40' Standard Height Container, Unit with Super Low Sound Fan

Once the sections have been unloaded from the shipping container, follow the below steps to complete assembly. Please check table of contents for associated page numbers to get to the instructions referenced below.

1. Unbolt fan section from basin section.
2. Lift fan section and rig to casing section using instructions from "Assembly of the fan section to the coil section (Containerized)"
3. Rig basin section using instructions from "Rigging Basin Section".
4. Lift upper section (fan + casing) and rig to basin using instructions from "Assembly of the Coil Section to the Basin (Containerized)"

While the image below is not representative of all possible accessory options, but it provides an example of how containerized unit's basins are set up for shipment. Platforms and ladders are strapped to the top of the casing.



* On Coolers & Condensers only. Not applicable to towers.

Assembly of the Fan Section to the Coil Section (Containerized)

7' and 14' (2.2 m and 4.4 m) Wide Models – Fan Section Will Need To Be Mounted to the Coil Section First

Four lifting U-Bolts are provided in the top corners of most fan sections for lifting into final position. 18' (5.5m), long sections will have two additional U-Bolts in the middle of the fan section. Use all U-Bolts. The hook of the crane must be a minimum dimension "H" above the top section being lifted to prevent undue strain on the section being lifted. See Table 3 for the minimum "H" dimension. These lifting devices should not be used for extended lifts or where any hazard exists unless safety slings are employed under the section. (See Extended Lifts' for proper arrangement.)

Before assembling the fan section to the coil section, wipe the flanges on the bottom of the fan section and apply sealer tape. Check to see that the motor access doors are in the correct position relative to the coil section (see certified print). Units are also provided with match markings on each section (i.e. A1 of the coil section should match up with the A1 of the fan section). Place nuts and bolts in all four corner bolt holes. Then continue to install the rest of the nuts and bolts working from the corners towards the center. Nuts and bolts are required on the end flanges. Drift pins are provided in rigging box to assist with alignment.

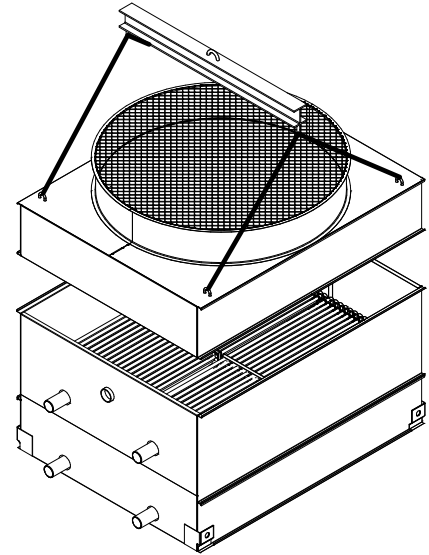

Figure 15 – Mating Fan Section to Coil Section

Assembly of the Coil Section to the Basin (Containerized)

7' and 14' (2.2 m and 4.4 m) Wide Models – Fan Section Will Need To Be Mounted to the Coil Section First

Before assembling the coil section to the basin section, remove any loose parts shipped in the pan. Four lifting ears are provided in the corners of coil sections for lifting into final position. 18' (5.5 m), long sections will have two additional lifting ears in the middle of the section. Use all lifting ears. When lifting assembled fan/coil sections, use the lifting ears at the bottom of the coil section and not the U-Bolts of the fan section. The hook of the crane must be a minimum dimension "H" above the lifting ear to prevent undue strain on the lifting ears. See Table 3 for the minimum "H" dimension. These lifting devices should not be used for extended lifts or where any hazard exists unless safety slings are employed under the section. (See Extended Lifts for proper arrangement.)

Before assembling the fan/coil section to the basin section, wipe the flanges on the bottom of the coil section and apply sealer tape to the basin section. Check to see that the access doors are in the correct position relative to the basin section (see certified print). Units are also provided with match markings on each section (i.e. A1 of the coil section should match up with the A1 of the fan section). Place nuts and bolts in all four corner bolt holes. Then continue to install the rest of the nuts and bolts working from the corners towards the center. Nuts and bolts are required on the end flanges. Drift pins are provided by others.

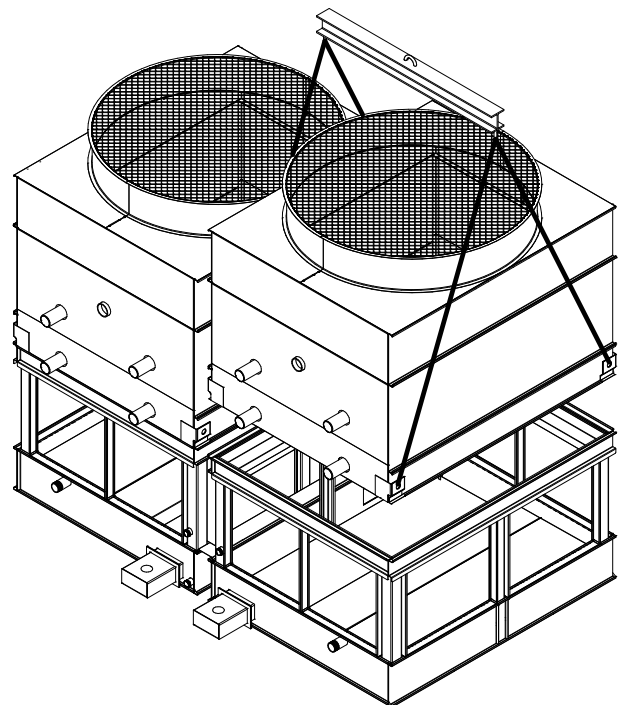

Figure 16 – Mating Fan/Coil Section to Basin Section

Installing Watertight Partitions & Firewalls

In some cases, a multi-cell unit is ordered with watertight partitions to allow for independent cell operation. To correctly assemble the upper sections to the bottom sections, access to the rigging seams in between cells is necessary. To facilitate with this access, the upper watertight partition is shipped loose for installation in the field. Figure 17 below provides instruction to install these in the field.

NOTE:

The below instruction and arrangement also applies for Factory Mutual (FM) Approved multi-cell units, in which case these partitions will be referred to as firewalls

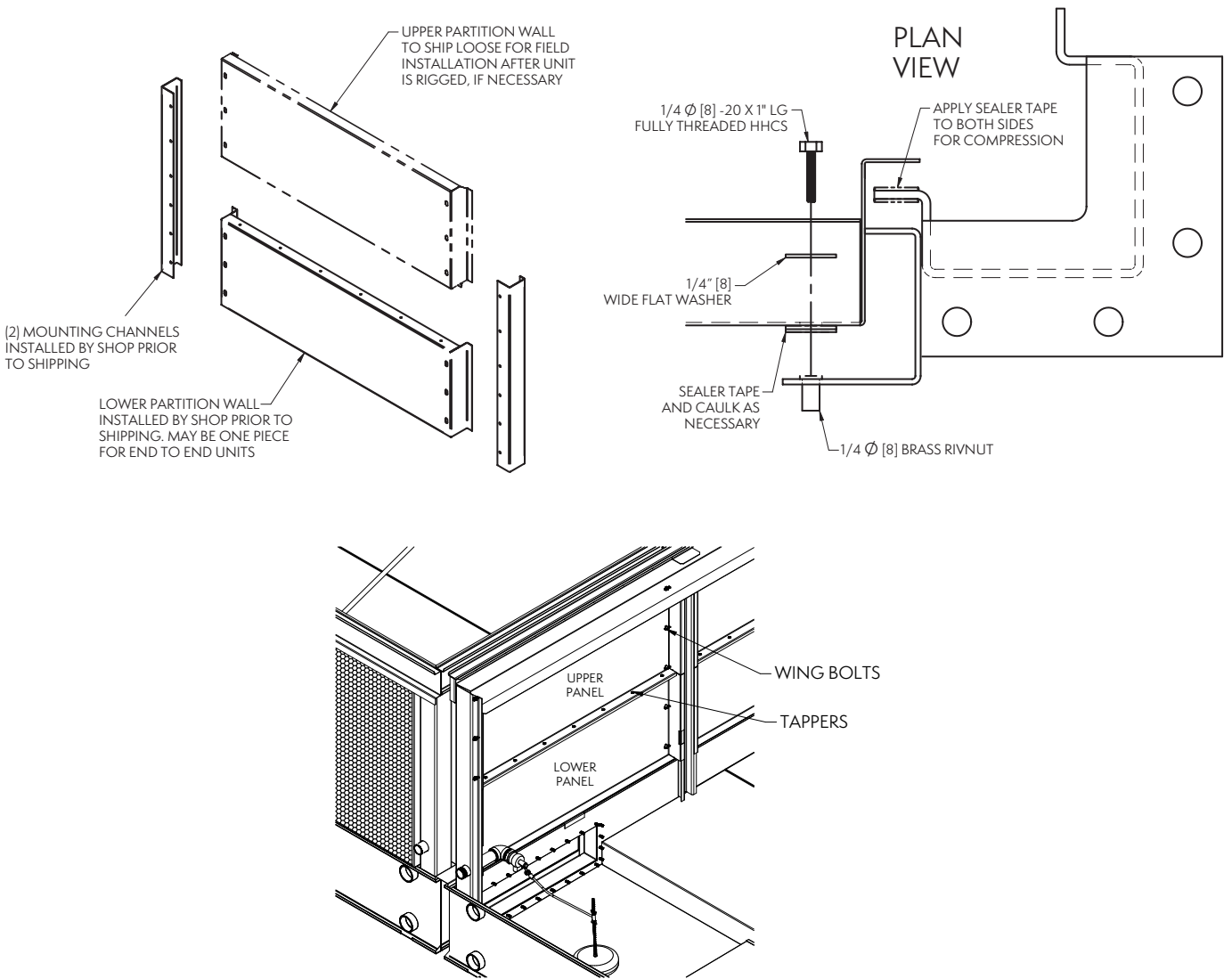

Figure 17 – Upper Partition/Firewall Installation in Field

External Motor Installation – Belt Drive

All units narrower than 10' (3 m) wide have their motors installed outside the unit in a shaft up configuration as shown in figures 18a and 18b below. Due to shipping width restrictions, these motors cannot ship mounted on the units since they would extend past the width of the truck. For this reason, the motor(s), motor base(s), motor guard(s), J-bolts, pivot pins and belt(s) are shipped in the cold-water basin of the cooling tower. Please follow the step-by-step instructions below to properly install these components.

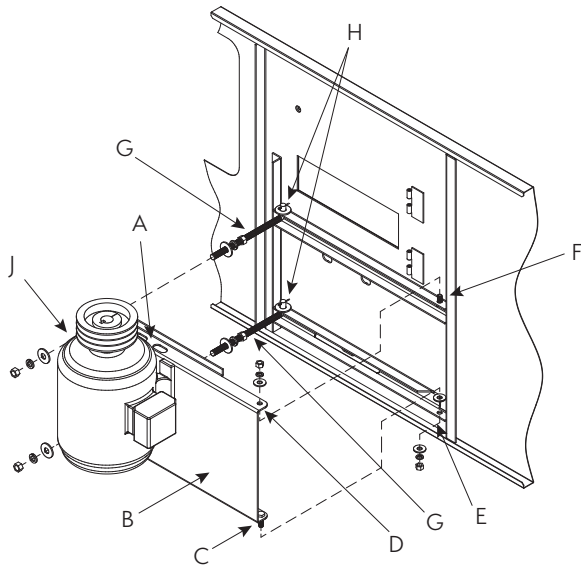

Figure 18a – External Motor Installation

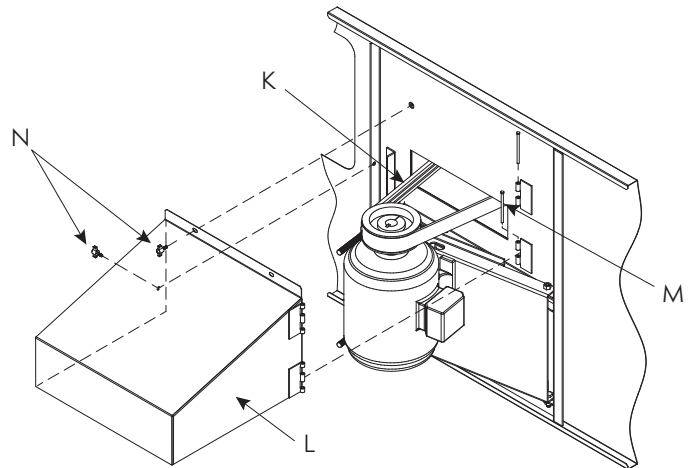

Figure 18b – Motor Guard and Power-Band Belt Installation

1. Study Figure 18a above before installing the motor base on the unit.
2. Insert the lifting device into the slots **A** located on the top of the motor base.
3. Lift the motor base **B** and insert the pivot pin **C** down into hole **E** and pivot pin **F** into hole **D**.
4. Install washer and nut (do not overtighten) on pivot pins. Install jam nut on pivot pin **C**.
5. Insert J-bolts **G** into holes **H**. Install flat washers and cotter pins. Place nuts and washers on threaded portion of J-bolts. These will be behind the motor base installed in the next step.
6. Install J-bolts **G** into holes **J** in the motor base. Install flat washers, lock washer and nuts. Remove lifting device from the motor base. Position motor base towards top section of unit for belt installation.
7. Install Power-Band belt **K** (Figure 18b) around fan sheave and motor sheave. Tighten belt by adjusting nuts on J-bolts. Do not overtighten the belts. The center of the belt should deflect approximately 3/4" (19 mm) in the horizontal plane with moderate hand pressure.
8. Measure to see that the top and bottom of the motor base are the same distance out from the casing of the unit. This will ensure that the sheaves are properly aligned since the driven sheave on the fan shaft comes preset from the factory.
9. As a final check, lay a straight edge from sheave to sheave as shown below in Figure 19. There should be four-point contact. Adjust the position of the motor sheave as necessary until four-point contact is achieved.
10. To install motor guard **L**, match up hinges and install hinge pins **M** as shown in Figure 18b.
11. Close motor guard **L** and install wing bolts **M**.

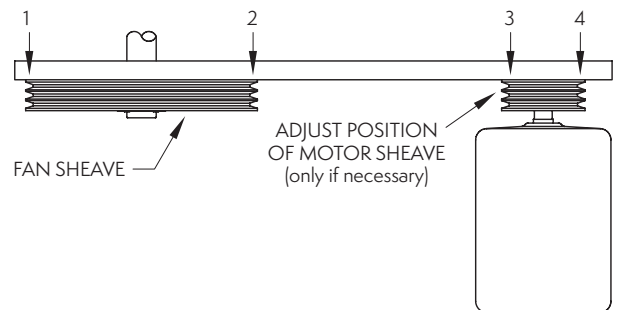

Figure 19 – Sheave Alignment Check

NOTE:

For European markets, additional belt cover plate needs to be installed.

Optional Motor & Gear Box Davit Installation

Motor davits, also known as jib-booms, are offered by EVAPCO as an optional accessory to facilitate removal of the motor, fan assembly or gear box. The assembly consists of a davit and a mounting base that is to be attached to the side of the unit next to the access door, as shown below in Figure 20. Both these items will ship loose in the unit's basin. On multi-cell units, there will be provisions to install a mounting channel on each cell. Use the following procedure to install the mounting channel:

1. Align the mounting channel with 3/8" (10 mm) bolts and flat washers to the factory installed mounting brackets.
2. Use 3/8" (10 mm) flat washers, lock washers and nuts to secure the mounting channel to the bracket, as shown in Figure 21.

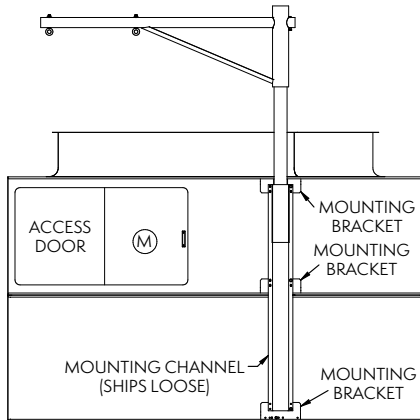

Figure 20 – Dual-Point Davit Arrangement

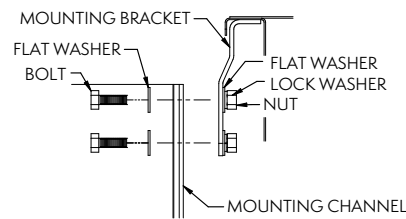

Figure 21 – Mounting Channel Installation

Mounting Fan Screens

On 10' (3 m) wide units and larger, a conical fan screen support is used in order to prevent the fan screen from sinking down into the fan cylinder. In some cases, shipping height restrictions may require the fan screen support(s) and fan screen(s) to ship loose for installation in the field. Please follow the below instructions to install these components on the fan cylinder(s).

1. Set the fan screen support across the top of the fan cylinder as shown in Figure 22.
2. Place both halves of the fan screen on top of the fan screen support. Each half will be tagged to match markings on the cylinder. Align the eyelets of the fan screen with the holes on the cylinder perimeter.
3. Join the two screen halves with "U" bolts, as shown in Figure 23.
4. At each hole, attach the fan screen to the fan cylinder as shown in Figure 22. At the four points where the fan screen support meets the cylinder, bolt the support to the cylinder together with the fan screen.

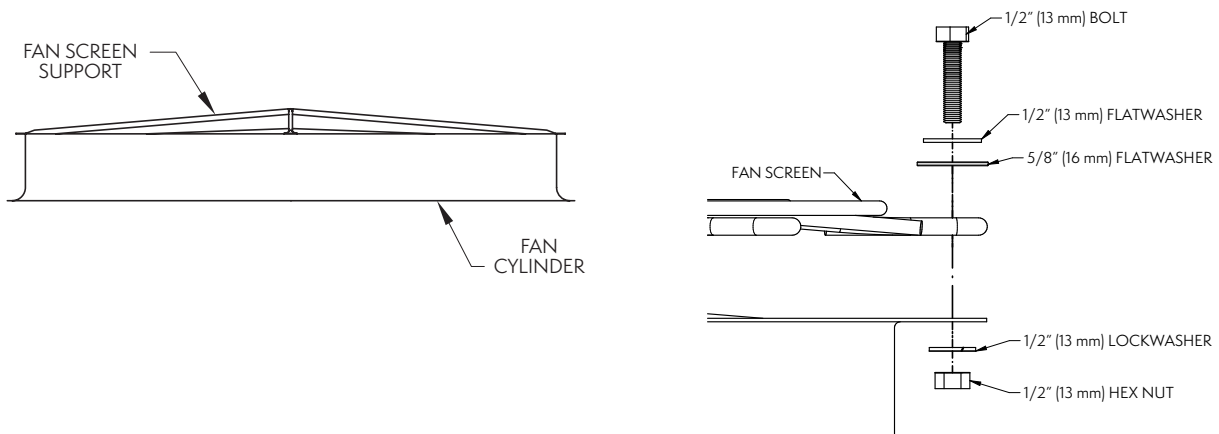

Figure 22 – Fan Screen Support & Fan Screen installation

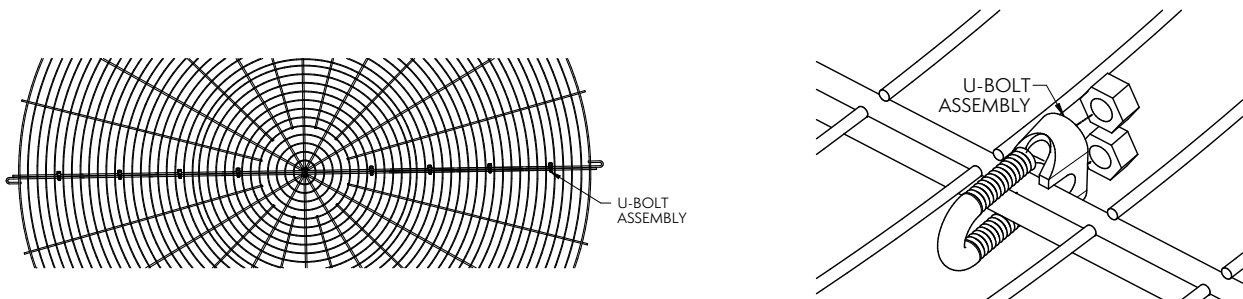

Figure 23 – U-Bolt Assembly Spacing & Arrangement

NOTE:

European market sometimes utilizes alternative CE compliant fan screen with 30 mm x 30 mm mesh. Screen has 120 mm clearance from trailing edge of fan blades.

Sloped Ladder Installation (Not available for European market)

When sloped ladders are supplied with a unit, they are shipped in the unit’s basin. One sloped ladder will be provided for each cell. Assembly is identical for each cell, unless otherwise noted in the submittal.

Sloped ladders are attached at a minimum of three points. At each point of attachment, the ladder will be fitted with a ladder bracket assembly. The ladder bracket assembly looks like a metal box and is shown as component (d) in Figure 24 below. The upper two assembly brackets will be rigidly mounted to the ladder and are not adjustable. These two brackets define the slope of the ladder. The lower bracket(s) are adjustable.

To install the ladder assembly, complete the steps that follow. Refer to Figure 24:

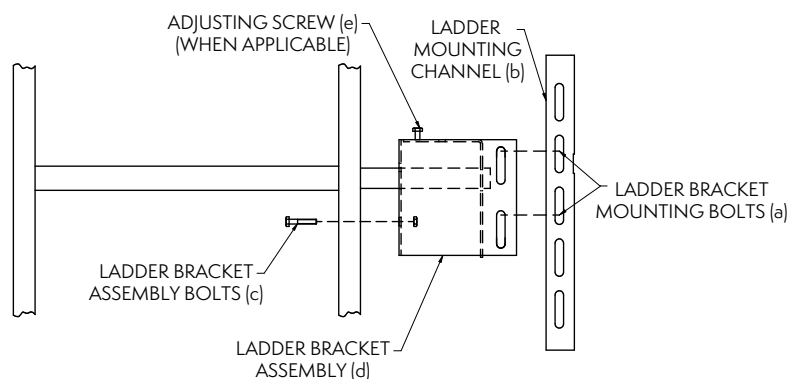

Figure 24 – Detail of Ladder, Ladder Bracket Assembly & Mounting Channel

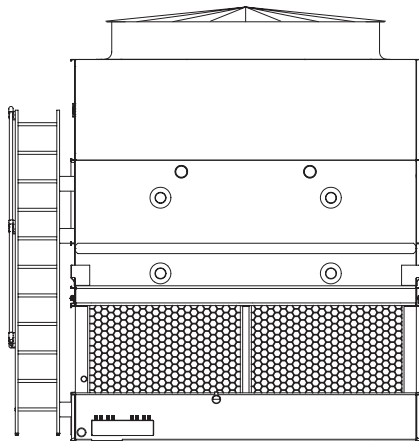

Figure 25a – End View of Ladder Assembly

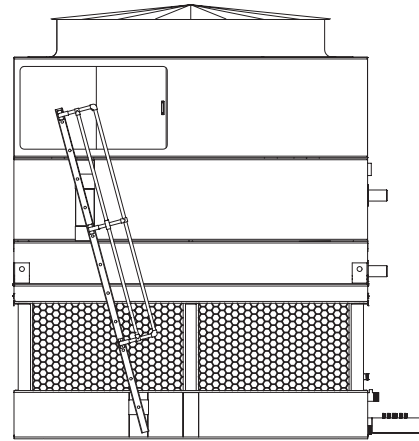

Figure 25b – Side View of Ladder Assembly

1. Remove the ladder bracket mounting bolts (a) from the ladder mounting channels (b) on basin and casing sections.
2. Loosen, but do not remove, the ladder bracket and assembly bolts (c).
3. Slide the bracket assembly (d) over the ladder mounting channels (b) located on the pan and casing sections. Do not remove the ladder bracket assembly (d) from the ladder.
4. Align the bolts and reinstall the ladder bracket assembly mounting bolts (a) through the ladder bracket assembly and the ladder mounting channels (b).
5. Tighten all bolts.
6. Tighten the adjusting screw (e) in the adjustable mounting bracket where applicable.

NOTES:

Upper section of unit must be properly oriented with respect to the lower section.

All mounting brackets must be on the same side of the unit. Refer to submittal for proper orientation.

Sloped ladders are not CE compliant & are not available for European market.



External Platform and Vertical Ladder Installation

If your unit is accessorized with an external service platform assembly with a vertical ladder, this equipment is shipped in the basin of your unit. In some cases, they are shipped separately due to other basin accessories that may interfere with storage. The platform is partially assembled prior to shipment to minimize field assembly.

Typically, there is one working platform and ladder assembly per fan section. Refer to your factory submittal for details.

The platform and ladder assembly should be attached after the unit is fully rigged, by following the instructions in the drawing below.

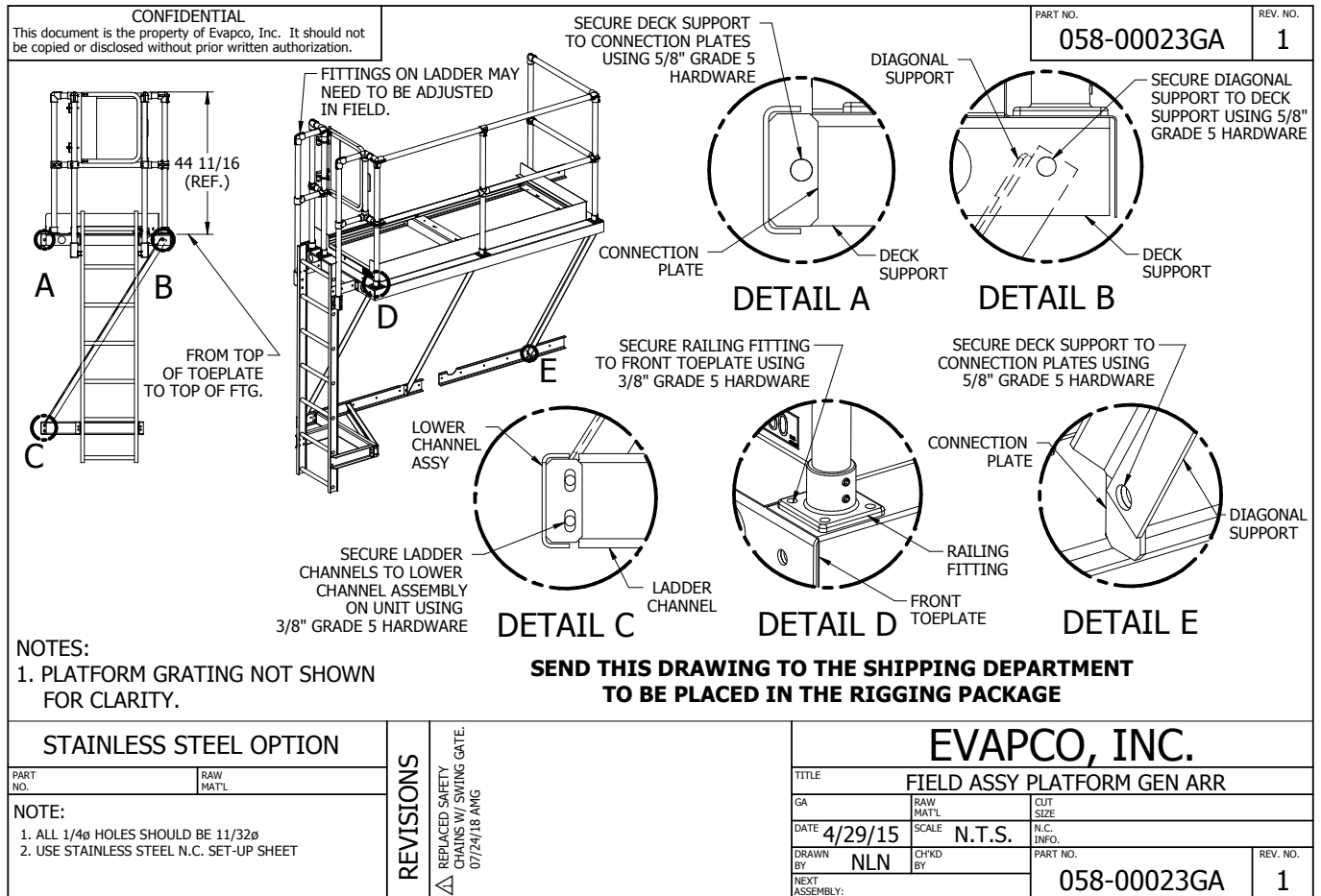

Figure 26 – Platform Mounting General Arrangement

Optional Discharge Hood Damper Section Assembly - ATW Models

Once the upper section (casing/fan section) has been secured to the bottom section, inspect the top of the upper section to ensure removal of any shipping blocks or other obstructions. Lower the discharge hood damper section onto the top of the upper section while aligning the holes located in each corner.

Place self-tapping bolts in all four corner bolt holes. Then continue to install the rest of the self-tapping bolts working from the corners toward the center using drift pins to align the holes. A self-tapper must be installed in every hole on the side flanges although none are required on the end flanges.

Note: Do not use U-bolts to lift the discharge hood damper section when attached to another part of the equipment. Always lift the hood separately and follow the rigging sequence shown.

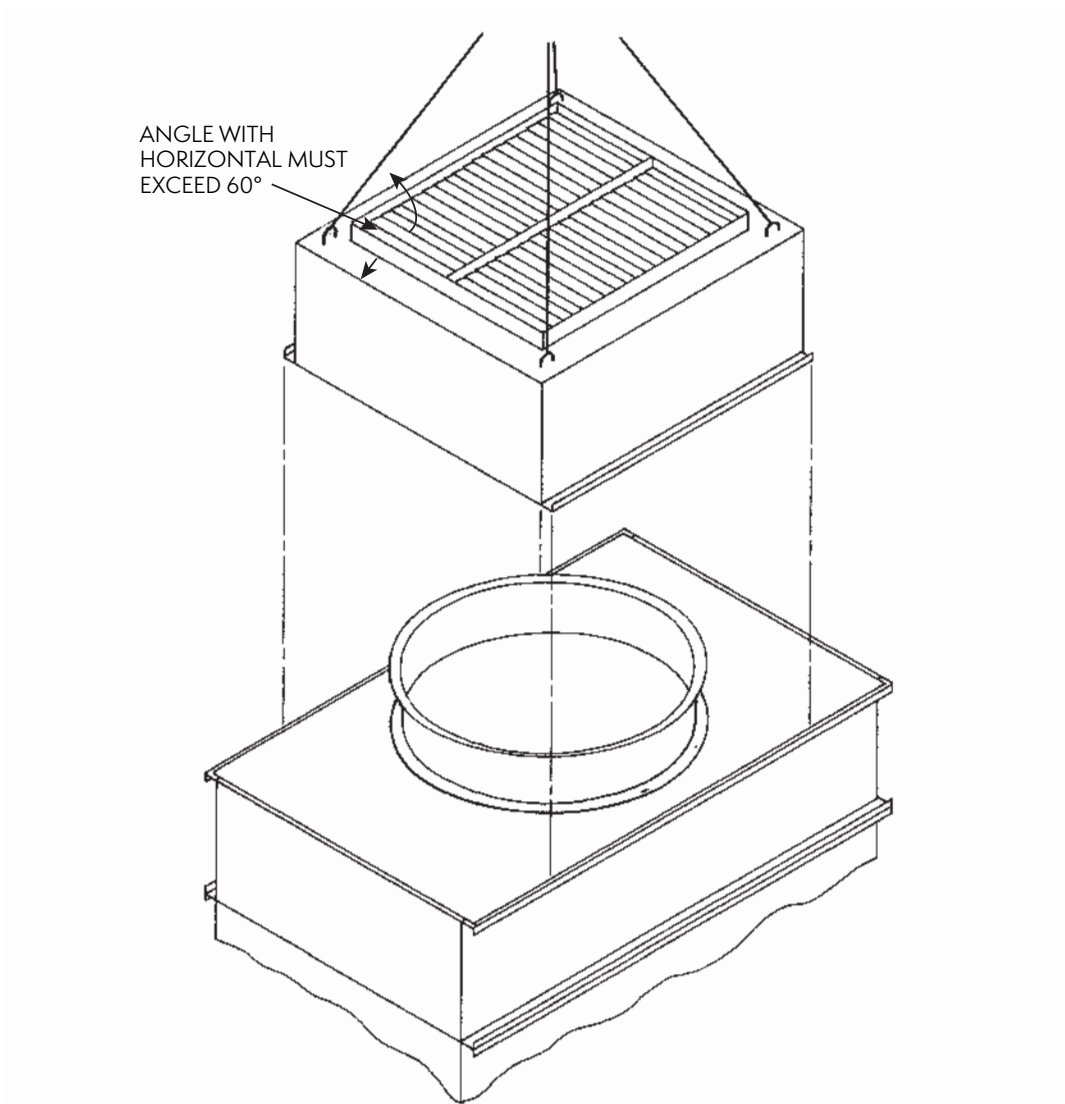
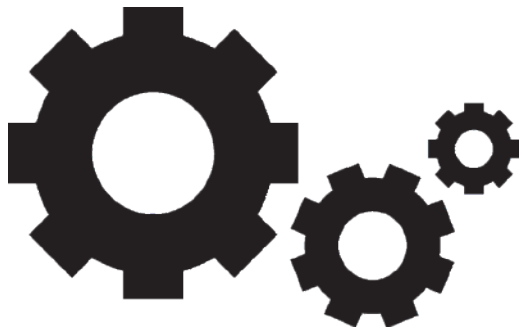

Figure 27 – Mating Discharge Hood Damper Section to Coil/Fan Section



**FOR EVAPCO AUTHORIZED
PARTS AND SERVICE,
CONTACT YOUR
LOCAL EVAPCO
REPRESENTATIVE
OR THE LOCAL
SERVICE CENTER**



Mr. GoodTower®



EVAPCO, Inc. — World Headquarters & Research/Development Center

P.O. Box 1300 • Westminster, MD 21158 USA
410.756.2600 • marketing@evapco.com • evapco.com

North America

EVAPCO, Inc.
World Headquarters
Westminster, MD USA
410.756.2600
marketing@evapco.com

EVAPCO East
Taneytown, MD USA

EVAPCO East
Key Building
Taneytown, MD USA

EVAPCO Midwest
Greenup, IL USA
217.923.3431
evapcomw@evapcomw.com

Evapcold Manufacturing
Greenup, IL USA

EVAPCO Newton
Newton, IL USA
618.783.3433
evapcomw@evapcomw.com

EVAPCO West
Madera, CA USA
559.673.2207
contact@evapcowest.com

EVAPCO Alcoil, Inc.
York, PA USA
717.347.7500
info@evapco-alcoil.com

EVAPCO Iowa
Lake View, IA USA

EVAPCO Iowa
Sales & Engineering
Medford, MN USA
507.446.8005
evapcomn@evapcomn.com

EVAPCO LMP ULC
Laval, Quebec, Canada
450.629.9864
info@evapcolmp.ca

EVAPCO Select Technologies, Inc. Bel-
mont, MI USA
844.785.9506
emarketing@evapcoselect.com

**Refrigeration Vessels &
Systems Corporation**
Bryan, TX USA
979.778.0095
rvs@rvscorp.com

Tower Components, Inc.
Ramseur, NC USA
336.824.2102
mail@towercomponentsinc.com

EvapTech, Inc.
Edwardsville, KS USA
913.322.5165
marketing@evaptech.com

EVAPCO Dry Cooling, Inc.
Bridgewater, NJ USA
908.379.2665
info@evapcodc.com

EVAPCO Dry Cooling, Inc.
Littleton, CO USA
908.895.3236
info@evapcodc.com

EVAPCO Power México S. de R.L. de C.V.
Mexico City, Mexico
(52) 55.8421.9260
info@evapcodc.com

Asia / Pacific

**EVAPCO Asia Pacific
Headquarters**
Baoshan Industrial Zone Shanghai, P.R. China
(86) 21.6687.7786
marketing@evapcochina.com

**EVAPCO (Shanghai)
Refrigeration Equipment Co., Ltd.**
Baoshan Industrial Zone, Shanghai, P.R. China

**EVAPCO (Beijing)
Refrigeration Equipment Co., Ltd.**
Huairou District, Beijing, P.R. China
(86) 10.6166.7238
marketing@evapcochina.com

**EVAPCO Air Cooling Systems
(Jiaxing) Company, Ltd.**
Jiaxing, Zhejiang, P.R. China
(86) 573.8311.9379
info@evapcochina.com

EVAPCO Australia (Pty.) Ltd.
Riverstone, NSW, Australia
(61) 02.9627.3322
sales@evapco.com.au

**EvapTech (Shanghai)
Cooling Tower Co., Ltd**
Baoshan District, Shanghai, P.R. China.
Tel: (86) 21.6478.0265

EvapTech Asia Pacific Sdn. Bhd.
Puchong, Selangor, Malaysia
(60) 3.8070.7255
marketing-ap@evaptech.com

Europe | Middle East | Africa

**EVAPCO Europe
EMENA Headquarters**
Tongeren-Borgloon, Belgium
(32) 12.39.50.29
info@evapco.be

EVAPCO Europe BV
Tongeren-Borgloon, Belgium

EVAPCO Europe, S.r.l.
Milano, Italy
(39) 02.939.9041
evapcoeuropa@evapco.it

EVAPCO Europe, S.r.l.
Sondrio, Italy

EVAPCO Europe A/S
Aabybro, Denmark
(45) 9824.4999
info@evapco.dk

EVAPCO Europe GmbH
Meerbusch, Germany
(49) 2159.69560
info@evapco.de

EVAPCO Middle East DMCC
Dubai, United Arab Emirates
(971) 56.991.6584
info@evapco.ae

Evap Egypt Engineering Industries Co.
A licensed manufacturer of EVAPCO, Inc.
Nasr City, Cairo, Egypt
(202) 10 054 32 198
evapco@riba-group.com

EVAPCO S.A. (Pty.) Ltd.
A licensed manufacturer of EVAPCO, Inc.
Isando, South Africa
(27) 11.392.6630
evapco@evapco.co.za

South America

EVAPCO Brasil
Equipamentos Industriais Ltda.
Indaiatuba, São Paulo, Brazil
(55) 11.5681.2000
vendas@evapco.com.br

FanTR Technology Resources
Itu, São Paulo, Brazil
(55) 11.4025.1670
fantr@fantr.com