

Rigging & Assembly Instructions

AXS

INDUCED DRAFT
CROSSFLOW
COOLING TOWERS



Mr. GoodTower®





Table of Contents

Introduction	3
Method of Shipment	3
Storage	5
Structural Steel Support	5
Rigging AXS Single Stack	5
Rigging AXS Double Stack	5
Joining Top and Bottom Section of AXS Double Stack	6
Joining Multi-Cell AXS Single and Double Stack	7
Optional Flume Box Blank-Off Plate for All Multi-Cell Units	8
Mounting Fan Screens and Fan Screen Supports	9
Super Low Sound Fan and Fan Cylinder Extension Installation	10
Inlet Piping	13
Outlet Piping	14
ASME Flange Pattern Sealing Instructions	15
Perimeter Handrail and Ladder Installation	16
Basin Level Platform and Vertical Ladder Installation	18
Firewall Installation	19
Louver Face Platform and Vertical Ladder Installation	20
Velocity Recovery (VR) Stack Assembly and Rigging	22
General Information – Startup & Maintenance	23
Belt Tensioning and Sheave Alignment	23
Bleed-Off Line	23
Adjustment of Float Valve	23
Strainer	24
Screens	24
Maintenance	24
Freeze Protection	24
External Motor Installation - Gear Drive	25
Internal Motor Mount – Gear Drive and Super Low Sound Fan	26
Floating Shaft Installation & Alignment	26
Appendix	29
Notes	30

The AXS INDUCED DRAFT CROSSFLOW COOLING TOWERS should be rigged and assembled using the instructions and recommendations outlined in this bulletin.

All personnel should review these procedures, as well as the latest industry-approved installation practices, prior to rigging and assembly. The information in this bulletin is for informational purposes only. These instructions do not purport to cover all variations and possible contingencies in connection with installation. Additionally, the procedures described herein are subject to change without prior notice, due to EVAPCO, Inc.'s ongoing research and development.

EVAPCO, Inc. makes no representations or warranties with respect to these instructions or the products described herein. Nor shall EVAPCO, Inc. be responsible for any loss or damage (direct, indirect, consequential, or other) during installation or handling of equipment after shipment.

For a full description of EVAPCO's liability policy, please visit www.evapco.com to access our Terms and Conditions.

Introduction

Thank you for purchasing your EVAPCO induced draft crossflow cooling tower. This manual will provide detailed instructions for rigging and installation of the cooling tower. If any questions arise during the installation, please contact your local EVAPCO representative.

Method of Shipment

EVAPCO's AXS cooling towers are available in single stack and double stack configurations. The single stack AXS towers will ship as a single section, and will require little to no assembly on site, except for external piping, electrical connections, and optional accessories as selected.

The double stack AXS cooling towers will ship in two sections, each of which will have mating flanges that will join together when sealed and bolted as described in the instructions that follow.

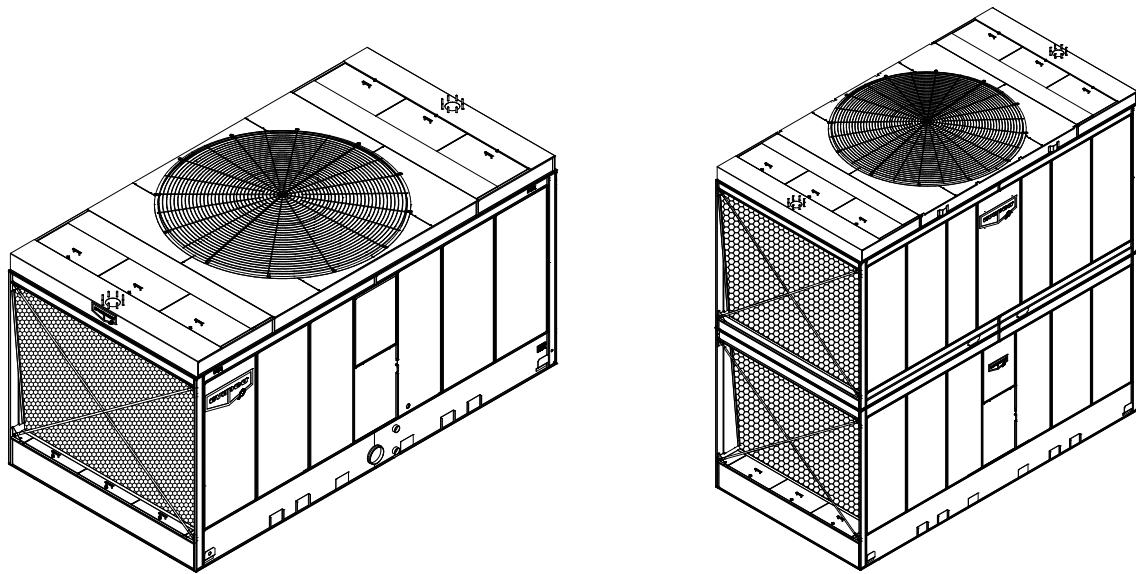

Figure 1 – Single Stack (Left) & Double Stack (Right) AXS Cooling Towers

Miscellaneous items, such as sealer tape, self-tapping screws and other required materials and hardware, are packaged in a rigging box which is placed inside the basin for shipment. EVAPCO recommends thoroughly inspecting the unit(s) and their related accessories upon receipt. Reviewing the most recent copy of the unit's submittal along with the rigging instructions before the unit arrives on site is also recommended.

The AXS cooling towers are available in belt and gear driven configurations. Belt driven units will come with motors and belts mounted from the factory. Checks for alignment and tensioning once the unit(s) are on site are recommended (this applies for gear driven units as well). Gear driven units with internally mounted motors will come with the motor, close coupling, and gearbox mounted from the factory. For gear driven units with externally mounted motors, the motor(s) and shaft(s) ship loose in the basin, and will have to be assembled and aligned in the field.

NOTE

All stainless steel rigging bolts should be coated with anti-seize spray on the threads to prevent nut galling.

Storage

Do not place tarps or other coverings over the top of the unit(s) if they are to be stored before installation. Excessive heat buildup can occur if the unit(s) are covered, causing possible damage to the PVC eliminators, louvers, or fill media. **For extended storage beyond six months, rotate the fan and fan motor shaft(s) monthly. Also, the fan shaft bearings should be purged and re-greased prior to startup.**

Structural Steel Support

Support beams and anchor bolts are to be furnished and sized by others. Always refer to the submittal packet or unit certified print for unit weights, dimensions and technical data.

Two structural I-beams running the length of the unit are required to support the unit in its longitudinal configuration (**Figure 2**). These beams should be located underneath the outer flanges of the unit. Mounting holes are located in the bottom flange of the unit to facilitate bolting to the structural steel. Exact bolt hole locations are provided on the structural steel print included in the submittal packet. The structural steel support arrangement will be the same for single and double stack units.

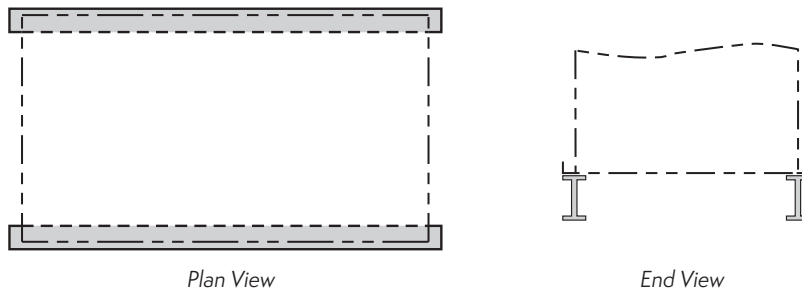

Figure 2 – Longitudinal Steel Support Arrangement

In addition to the longitudinal steel support arrangement, transverse arrangements are also possible, as shown below in **Figure 3**. For acceptable overhang limits in the transverse arrangement, please refer to EVAPCO's Equipment Layout Manual which details transverse steel arrangements, or contact your local EVAPCO representative.

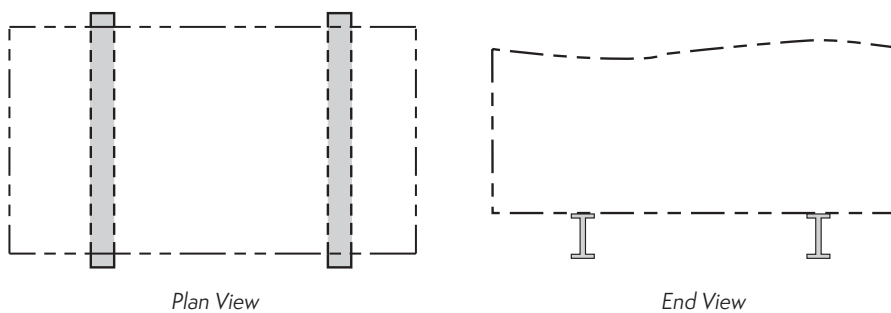

Figure 3 – Transverse Steel Support Arrangement

Beams should be sized in accordance with accepted structural practices. Maximum deflection of the beam under the unit should be $1/360$ of the unit length, not to exceed $1/2$ " (13 mm). Deflection may be calculated by using 55% of the **operating** weight as a uniform load on each beam. Operating weights can be found on the unit certified print, included in the submittal packet.

The supporting I-beams should be level before setting the unit. **Do not level the unit by shimming between the bottom flange of the unit and the beams, as this will not provide proper support.**

Rigging AXS Single Stack

Lifting devices are located on the bottom corners of the long sides of the AXS cooling towers. The spreader bar to which the hook of the crane attaches, must be a minimum dimension of "H" above the lifting ears.

Unit	Minimum "H"	
12' Wide AXS	19 ft	5.8 m
14' Wide AXS	20 ft	6.1 m

Table 1 – AXS Single Stack Min. "H" Dimension

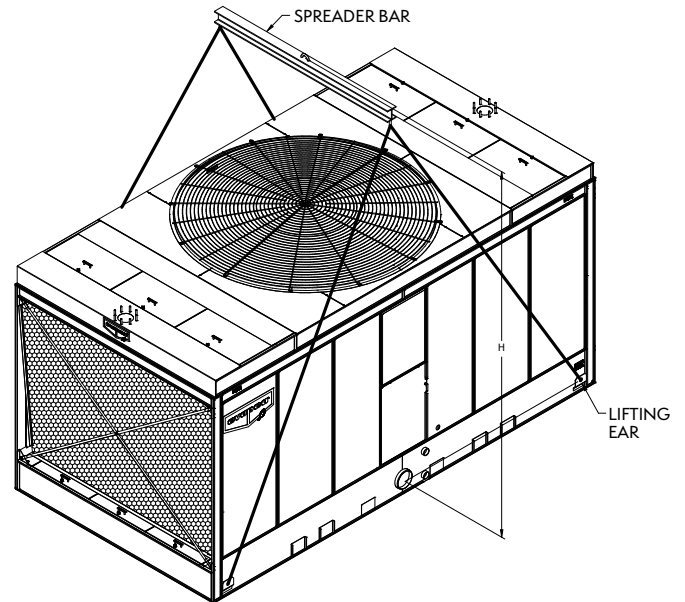

Figure 4 – AXS Single Stack Min. "H" Dimension

Rigging AXS Double Stack

The AXS double stack ships in two sections, and therefore individual rigging of each section is required. Figures 5 and 6 show the lifting ear location, and the same rules in terms of minimum "H" dimension as the AXS single stack cooling tower apply.

Unit	Minimum "H"	
12' Wide AXS	19 ft	5.8 m
14' Wide AXS	20 ft	6.1 m

Table 2 – AXS Double Stack Min. "H" Dimension

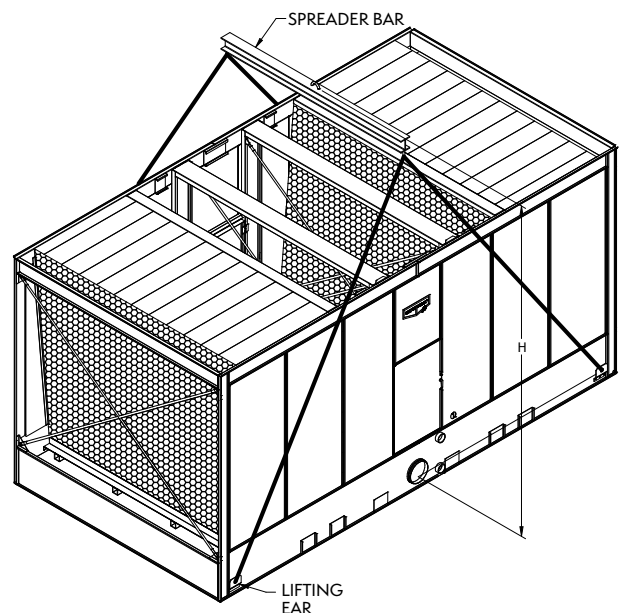

Figure 5 – AXS Double Stack Bottom Section Min. "H" Dimension

After bottom section is in place, refer to **Figure 6** for instructions to rig top section. The lifting ears are located toward the top of the unit, as shown below. The spreader bar to which the hook of the crane attaches, must be a minimum dimension of "H" above the lifting ears.

Unit	Minimum "H"	
12' Wide AXS	8 ft	2.4 m
14' Wide AXS	10 ft	3.0 m

Table 3 – AXS Double Stack Top Section
Min. "H" Dimension

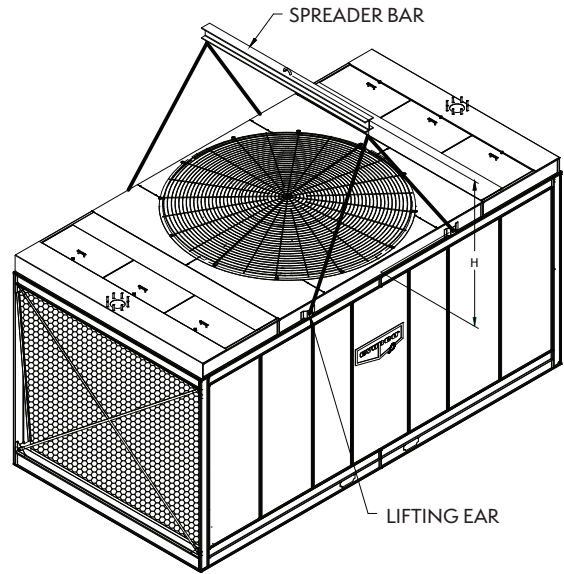

Figure 6 – AXS Double Stack Top Section Min. "H" Dimension

Joining Top and Bottom Sections of the AXS Double Stack

Once the bottom section of the AXS double stack has been set and bolted onto the structural steel support, sealer tape application must be completed before the top section is lifted and rigged.

Sealer tape must be laid on the flanges of both long sides, such that it is centered over the mounting holes. See **DETAIL A** of **Figure 7** below. The fill supports will also need to have a layer of sealer tape, as shown in **DETAIL B** of **Figure 7** below.

At the points where the fill supports meet the flanges on the long sides, the sealer tape must overlap, and a small piece of sealer tape must be applied perpendicular to the tape from the fill support to ensure a watertight seal.

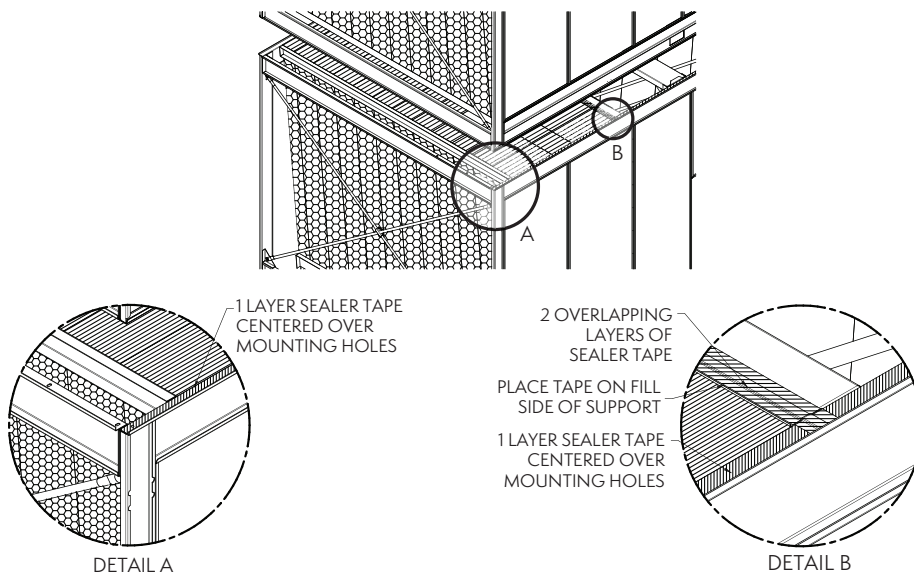

Figure 7 – AXS Double Stack Sealer Tape and Bolting Detail

Once sealer tape has been applied to the appropriate locations on the bottom section, proceed to rig the top section.

Bolting is required at the center attachments on the long sides (See **DETAIL B** of **Figure 8**), and at the air inlets.

In addition to the alignment aids provided (see **DETAIL A** of **Figure 8**), the use of drift pins to align bolt holes on the air intake sides is encouraged.

Holes in the mating flanges are 7/16" (11 mm) slots and the top section can be fastened to the bottom using the 3/8" (10 mm) hardware provided, as depicted in **DETAIL C** of **Figure 8**.

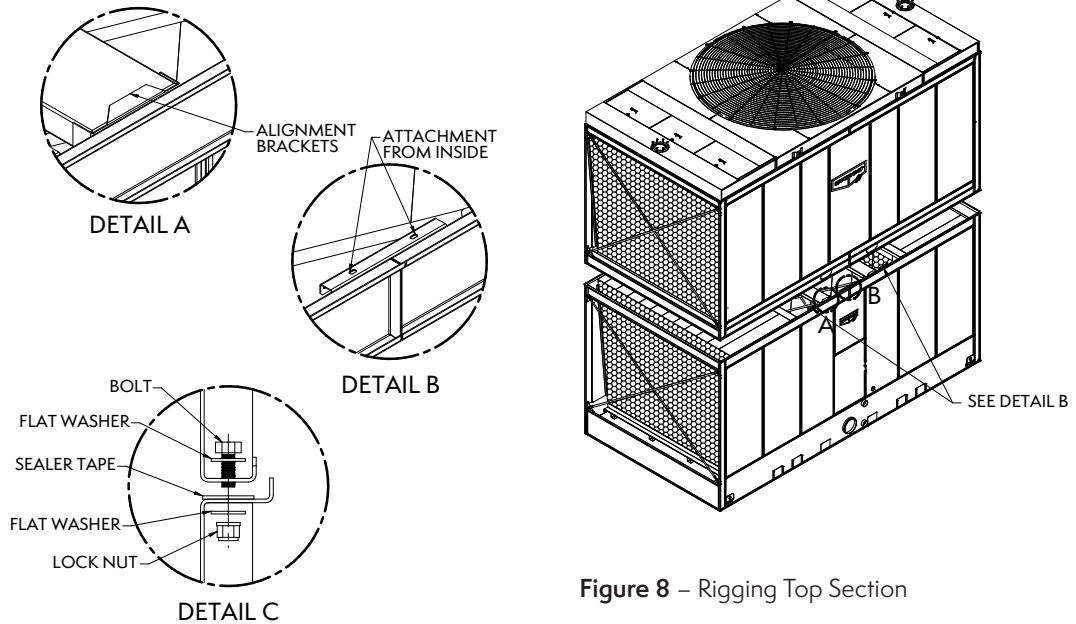

Figure 8 – Rigging Top Section

Joining Multi-Cell AXS Single and Double Stack

AXS towers selected in multi-cell configurations may come with a connecting equalizer flume between them. The number of flume boxes in the total arrangement will depend on the number of towers selected. For example, a dual cell arrangement calls for one flume box, three cell arrangements call for two flume boxes, with the center cell having one flume box on either side, and so on. The equalizing flume always ships loose in the basin(s). It is important to connect the flume box to balance the water level in the pans for proper pump suction operation. Flume boxes are not required if the towers are being provided with equalizer connections (piping by others).

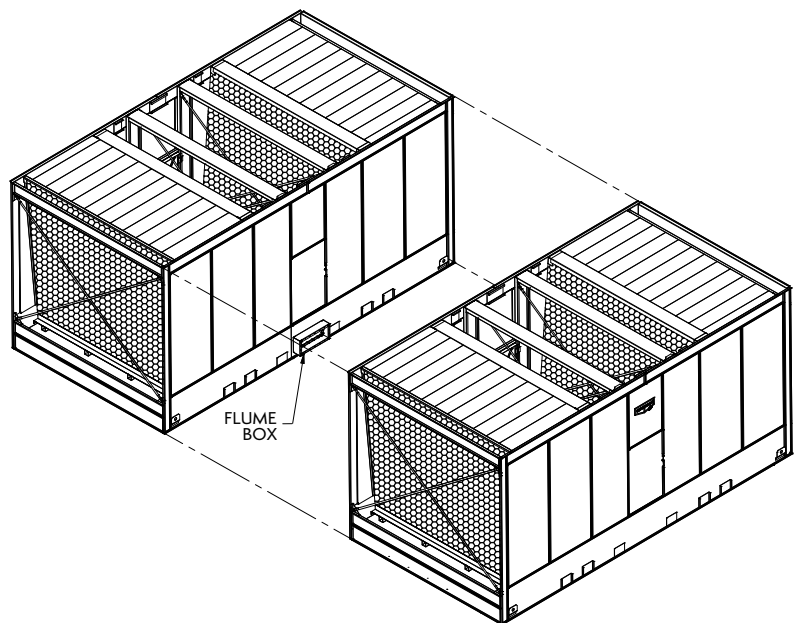

Figure 9 – Flume Box to Equalize Multi-Cell Arrangements

1. Install the AXS single stack, or bottom section of the double stack as described in the rigging instructions and bolt to steel.
2. Clean the flanges of the equalizer flume openings on all cells. Apply a layer of sealer tape around the flume openings on all cells, centered over the bolt holes. Remove paper backing strip from the sealer tape.
3. Clean the mating flange on the equalizer flume opening of any dirt, grease, or moisture.
4. The side of the flume box which has the studs installed in it should now be connected to the side panel. The studs are pushed through the sealer tape and holes of the side panel and are secured by washers, and lock nuts.

5. Rig the second AXS single stack, or bottom section of the double stack adjacent to the equalizer flume on the steel support.
6. Align the bolt holes in the equalizer flume and the equalizer opening with drift pins, while drawing the second bottom section against the flanged connection (**Figure 10**).
7. Install 3/8" (10 mm) bolts, nuts, and washers in every hole around the equalizer flume opening and tighten.
8. Bolt the second AXS single stack, or bottom section of AXS double stack, to the steel support.
9. Continue this process for all additional cells.

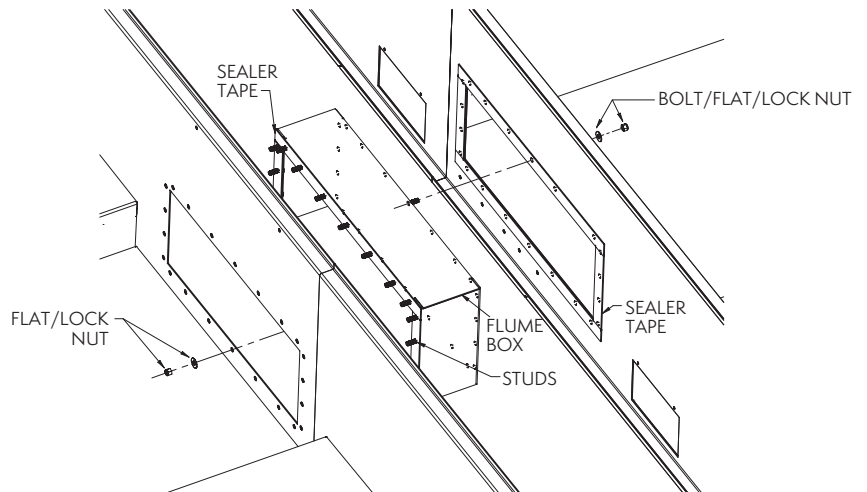

Figure 10 – Flume Box Detail

Optional Flume Box Blank-Off Plate for All Multi-Cell Units

An accessory is available to isolate the bottom sections for individual cell operation, periodic cleaning, or maintenance. This optional blank-off plate is secured to the flume box with nuts and ships in the basin.

For applications not requiring the blank-off plate, remove the nuts, washers and plate. Reinstall washers and nuts for proper leak free operation of the flume box.

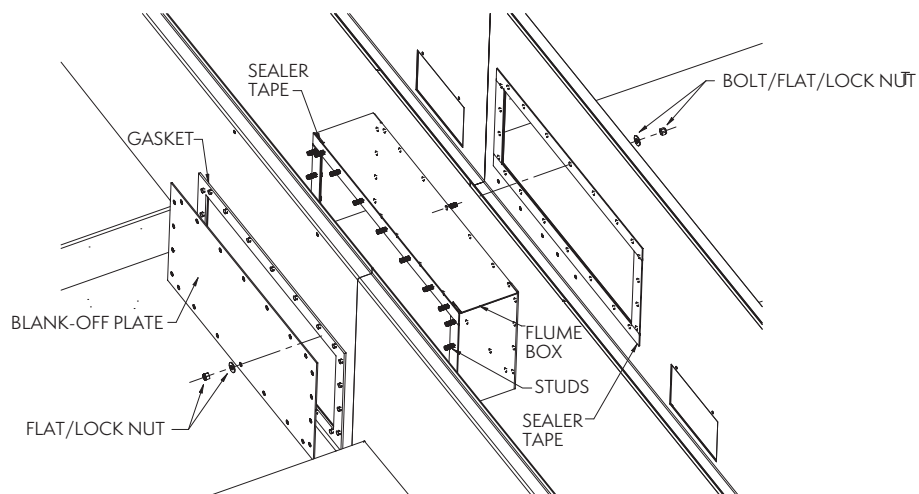

Figure 11 – Optional Blank-Off Plate on the Flume Box

Mounting Fan Screens and Fan Screen Supports

Fan screen(s) and fan screen support(s) ship loose in the basin for field assembly. Please follow the below instructions to complete the assembly:

1. Secure the fan screen support as depicted in DETAIL A of **Figure 12**.
2. Place both halves of the fan screen on top of the fan screen support frame. Each half will be tagged to match markings on the cylinder. Align the eyelets on the fan screen with the holes on the cylinder perimeter.
3. Join the two screen halves with U-bolt wire clips, spaced evenly, as shown in DETAIL B of **Figure 12**.
4. At each hole, attach the fan screen to the discharge cylinder as shown in DETAIL D of **Figure 12**. At the four points where the fan screen support frame meets the cylinder, bolt the support frame to the cylinder together with the fan screen.

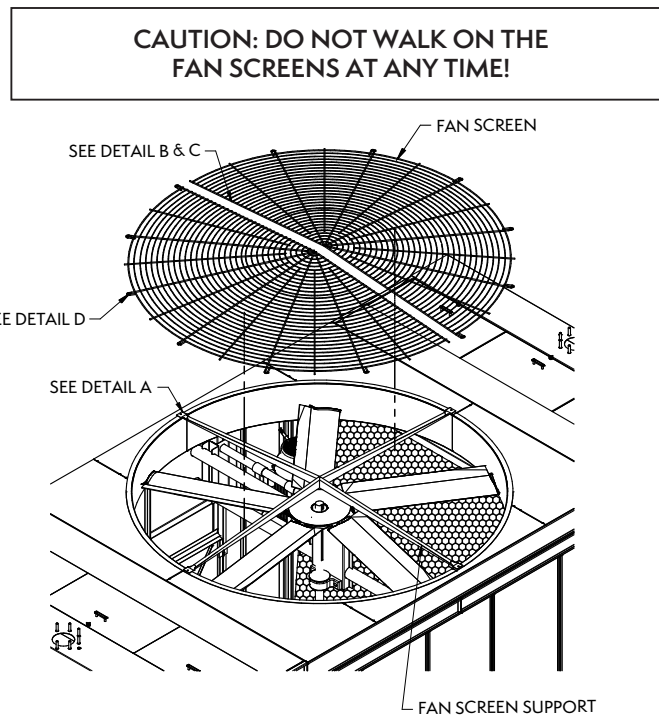
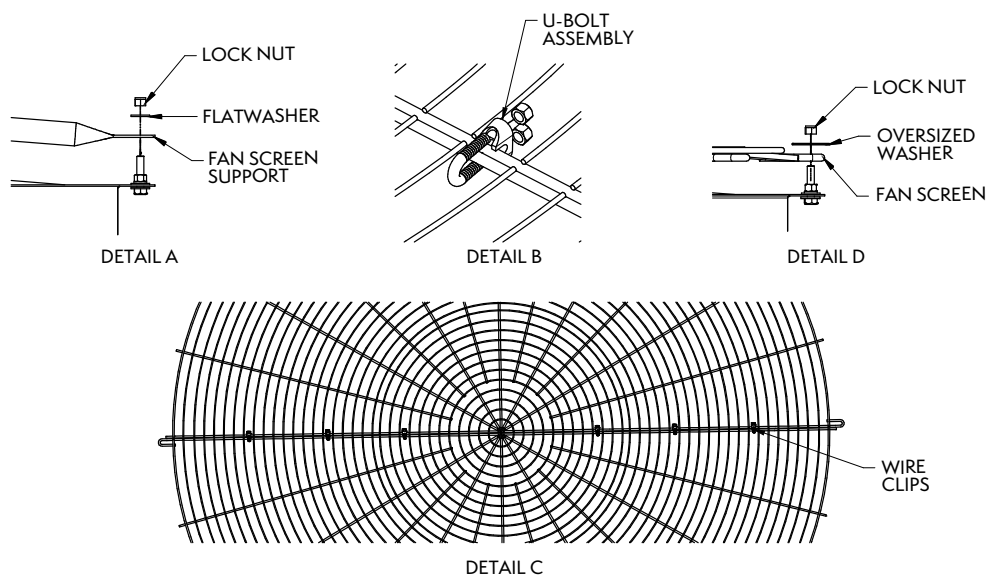

Figure 12 – Fan Screen and Fan Screen Support Frame



Super Low Sound Fan and Fan Cylinder Extension Installation

Due to shipping restrictions, the super low sound fan and fan cylinder extension will ship crated for field assembly on 11' and 22' tall units. Please follow the instructions below for proper fan installation.

Remove locking collar and retaining plate, as shown in **DETAIL A** of **Figure 13** below.

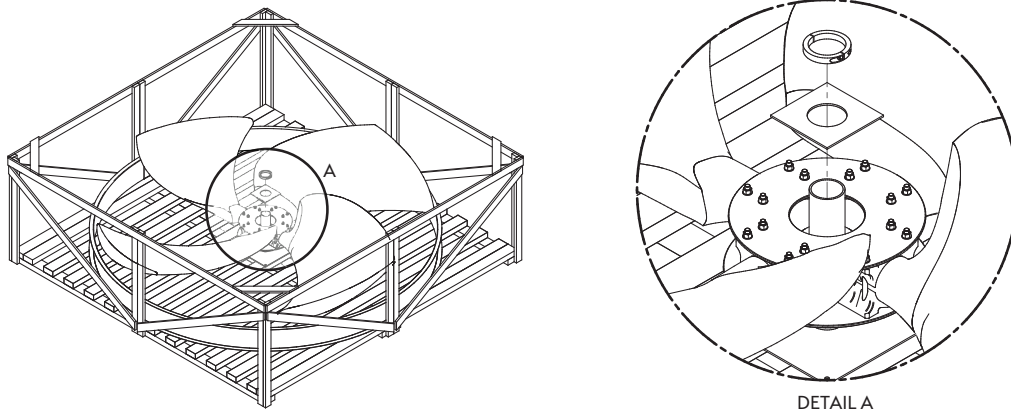

Figure 13 – Crated SLSF

Wrap slings around the blade shanks and lift fan from the crate, as shown in **DETAIL A** of **Figure 14** below.

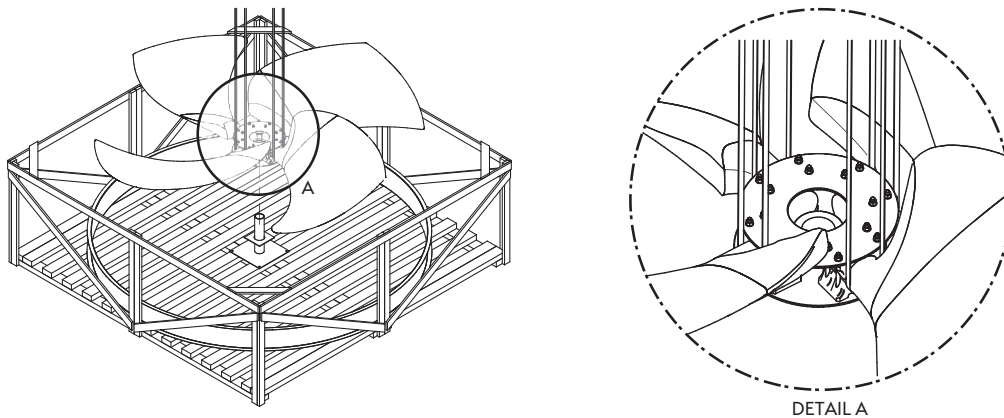

Figure 14 – Removing Fan from Crate

Slowly lower the fan onto the shaft, until the bottom of the hub is flush with the factory installed locking collar.

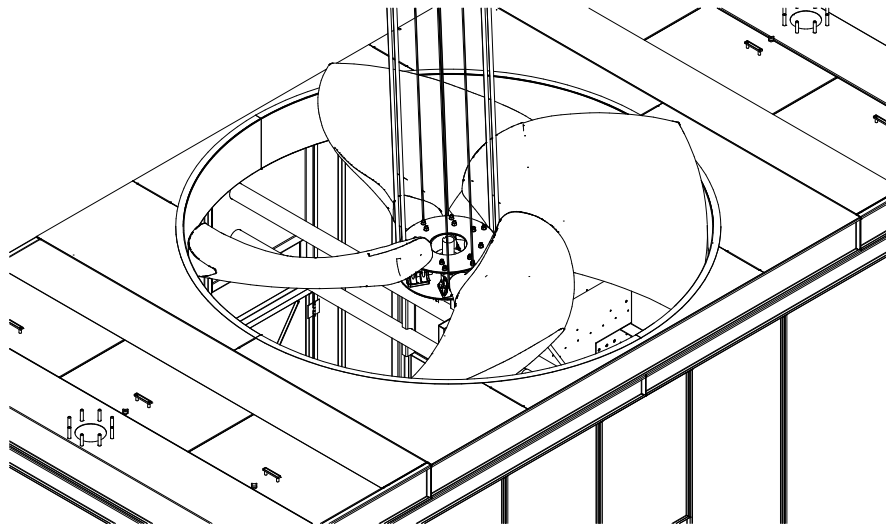

Figure 15 – Lowering Fan onto Shaft

Line up key slots and gradually tighten the three bushing bolts on the taper-lock bushing such that it locks onto the shaft and sits evenly in the hub flange. See DETAIL A of Figure 16 below

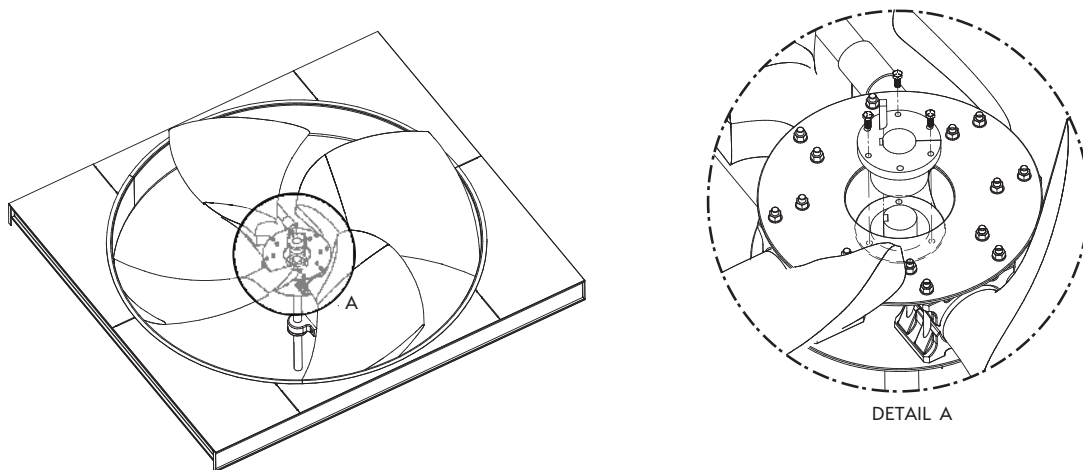
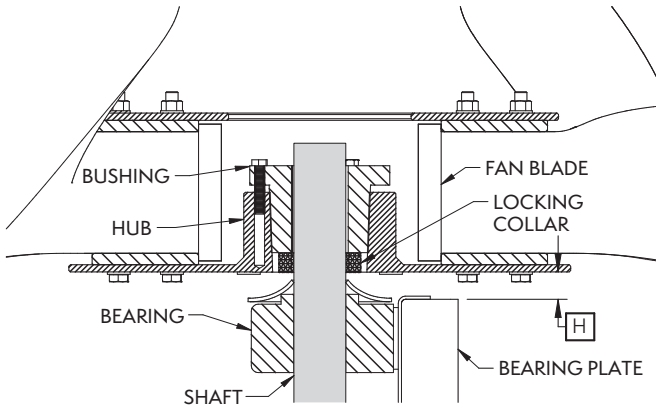

Figure 16 – Installing Taper Lock Bushing

Bushing	Torque	Bolt
J	135 ft-lb. (180 N.m)	5/8 - 11 x 4-1/2" (M16 x 2 - 115 mm)

Table 4 – Relevant Measurements for Installing Taper Lock Bushing

Once the taper lock bushing has been installed, please verify "H" dimension per **Table 5** below, to ensure proper fan placement with respect to the bearing plate.



Fan Diameter (in.) / cm	Unit Size	"H" Height (in.)	"H" Height (mm)
(132) 335 cm	12' x 22'	1	25
(156) 396 cm	14' x 24'	1-1/4	35

Table 5 – Measurements to Verify Fan Placement

Figure 17 – Verifying Fan Placement

Install fan cylinder per below, using **DETAIL A** and **DETAIL B** for reference. Please ensure that the fan screen supports have been installed along with the fan screen prior to installing the cylinder.

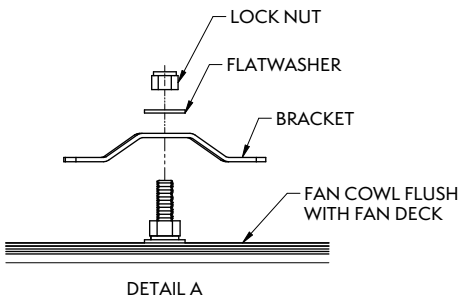

DETAIL A

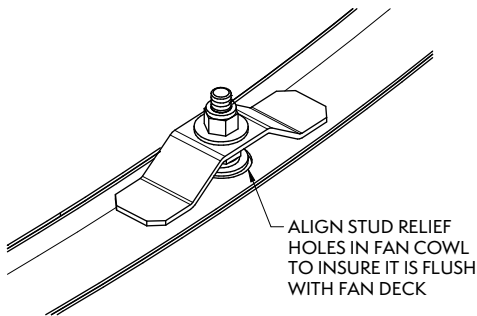

DETAIL B

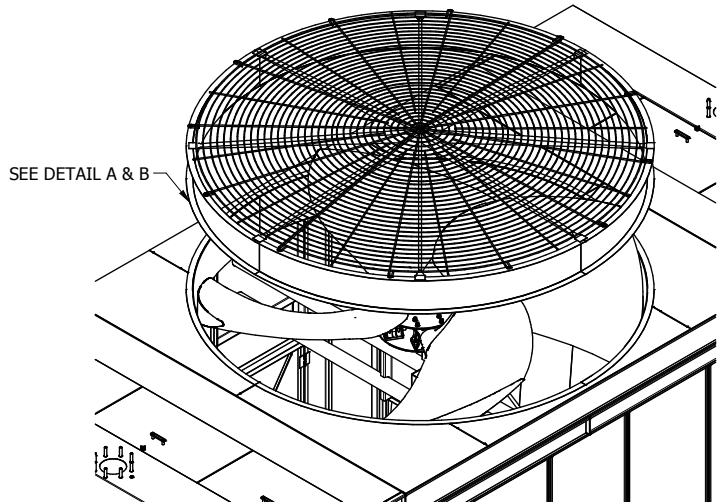

Figure 18 – Installing Fan Cylinder

Inlet Piping

The AXS cooling towers have three possible piping configurations. A single side inlet, a single bottom inlet, or dual top inlets. The single side and bottom inlets have their internal piping configured such that the flow to both hot water basins, which are located on the fan deck, is balanced. Single side inlets are available in single or dual cell configurations. In multiple cell configurations, bottom inlets or dual top inlets are typical.

Bottom Inlet

If a unit with a bottom inlet is provided, as shown in **Figure 19**, the internal riser pipe, pipe connector and clamps, and the two connecting pieces of pipe which are located on the fan deck are provided.

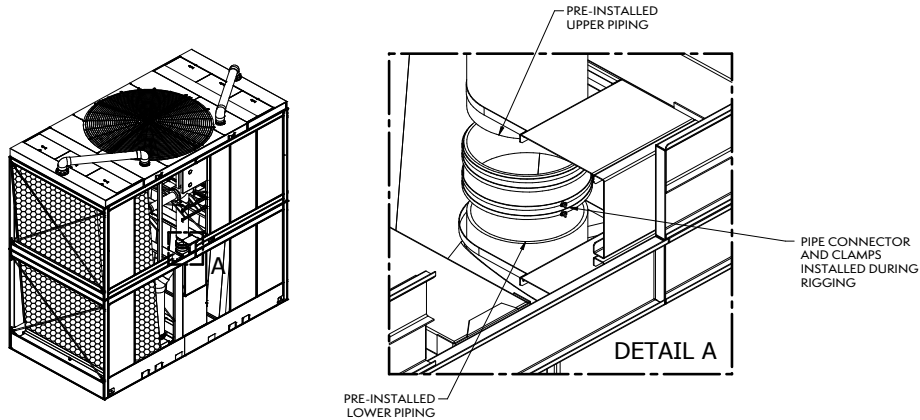

Figure 19 – Single Side Inlet

Weep Hole

A weep hole, as shown in **Figure 20**, is provided to drain internal piping during pump shut down. It is recommended to remove the drain plug during cold weather operation. The drain plug ships loose in the rigging box.

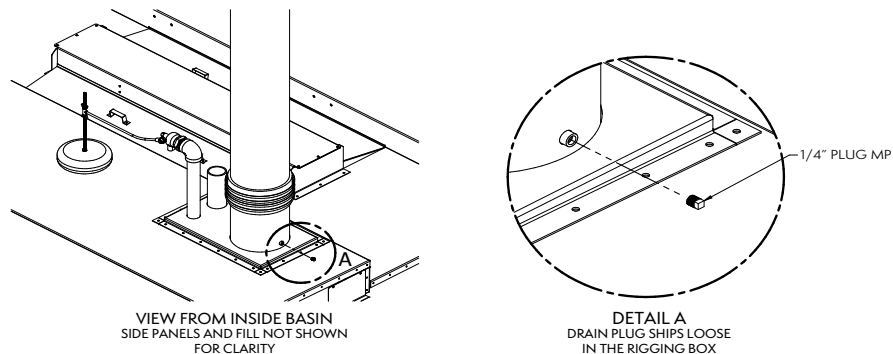

Figure 20 – Weep Hole

Due to shipping restrictions, the piping that connects to each hot water box on the fan deck ships loose for field installation. One side connects to the hot water box via the flange setup. The opposite end attaches through the fan deck to the factory mounted internal piping via a hose clamp. **See Figure 21** for details.

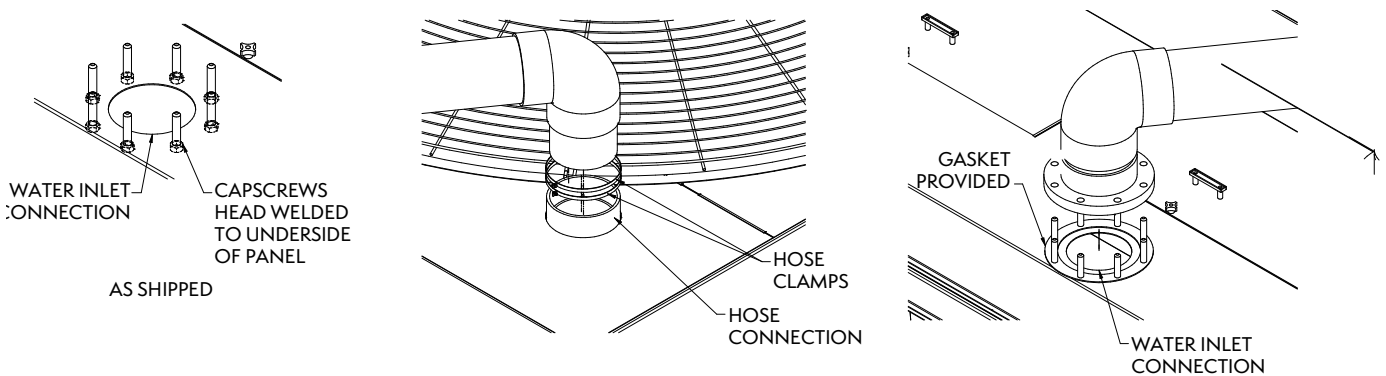

Figure 21 – ASME 150 Bolt Flange Pattern Setup

Side Inlet

If EVAPCO provides a unit with a side inlet, the two connecting pieces of pipe which are located on the fan deck, as shown in **Figure 22**, are provided. They must, however, be piped in the field.

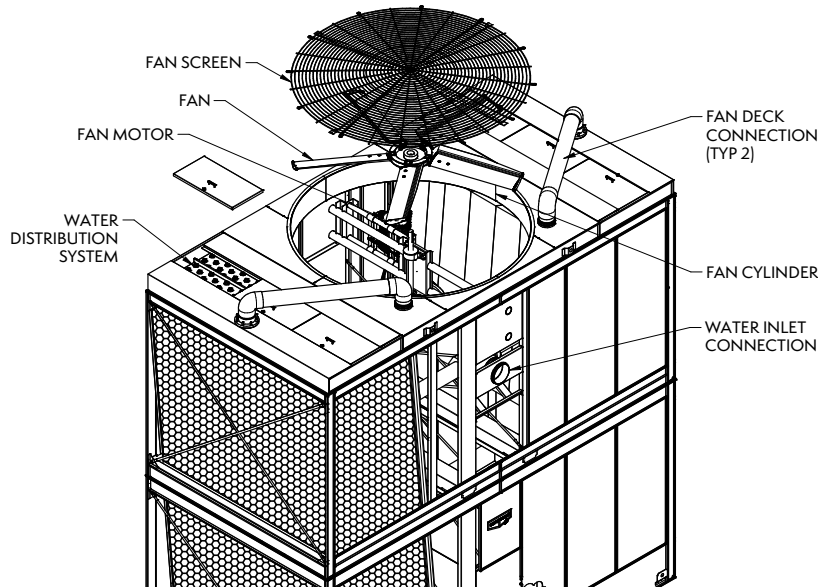

Figure 22 – Single Side Inlet

Dual Top Inlets

If units are provided with dual top inlets, no piping is provided from the factory.

Outlet Piping

The AXS cooling towers have three possible outlet piping configurations. A side outlet, a bottom outlet, or a side outlet depressed sump box. Side outlets are provided as standard in single or dual cell configurations. In situations where more than two cells are to be installed side-by-side, bottom outlets or side outlet depressed sump boxes can be provided. Side and bottom outlets require no assembly in the field, with the exception of connection to external piping. Side outlet depressed sump boxes ship loose in the basin, and require installation in the field. Please follow below instructions to complete installation of the side outlet depressed sump box:

1. Locate square opening in the deepest part of the towers basin. Apply sealer tape over the bolt holes surrounding the opening, as shown in **Figure 23**.
2. Lower the side outlet depressed sump box through the opening such that the bolt holes on its flanges match up with the holes surrounding the opening.
3. Complete installation using provided hardware, as shown in **DETAIL A** and **DETAIL B**.

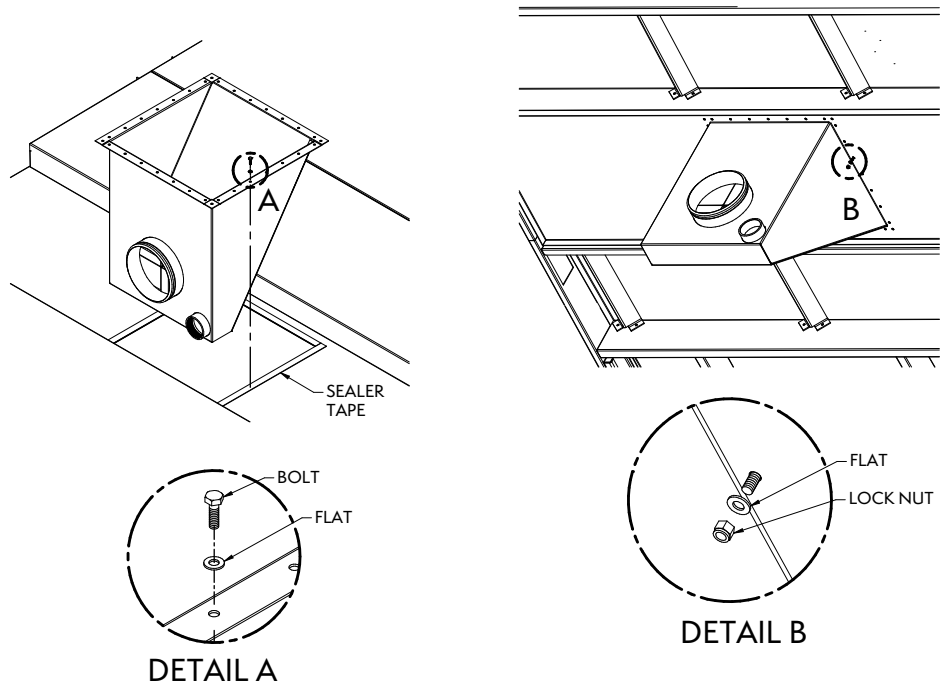

Figure 23 – Side Outlet Depressed Sump Box Installation

ASME Flange Pattern Sealing Instructions

If unit is provided with optional ASME Bolt Pattern, follow the instructions below for proper connection of flange. Evapco will provide the sealer tape and backer plate. Flanges, gaskets, bolts, etc are provided by others.

NOTES:

Flange connection confirms to ASME B16.5 class 150 specification. flat face flange, full face gasket, and fasteners supplied by others. All piping shall be externally supported by others. Piping must not be supported by the tower. Caulk all bolt heads and flat washers after all bolts are tightened. Caulk perimeter backer plate.

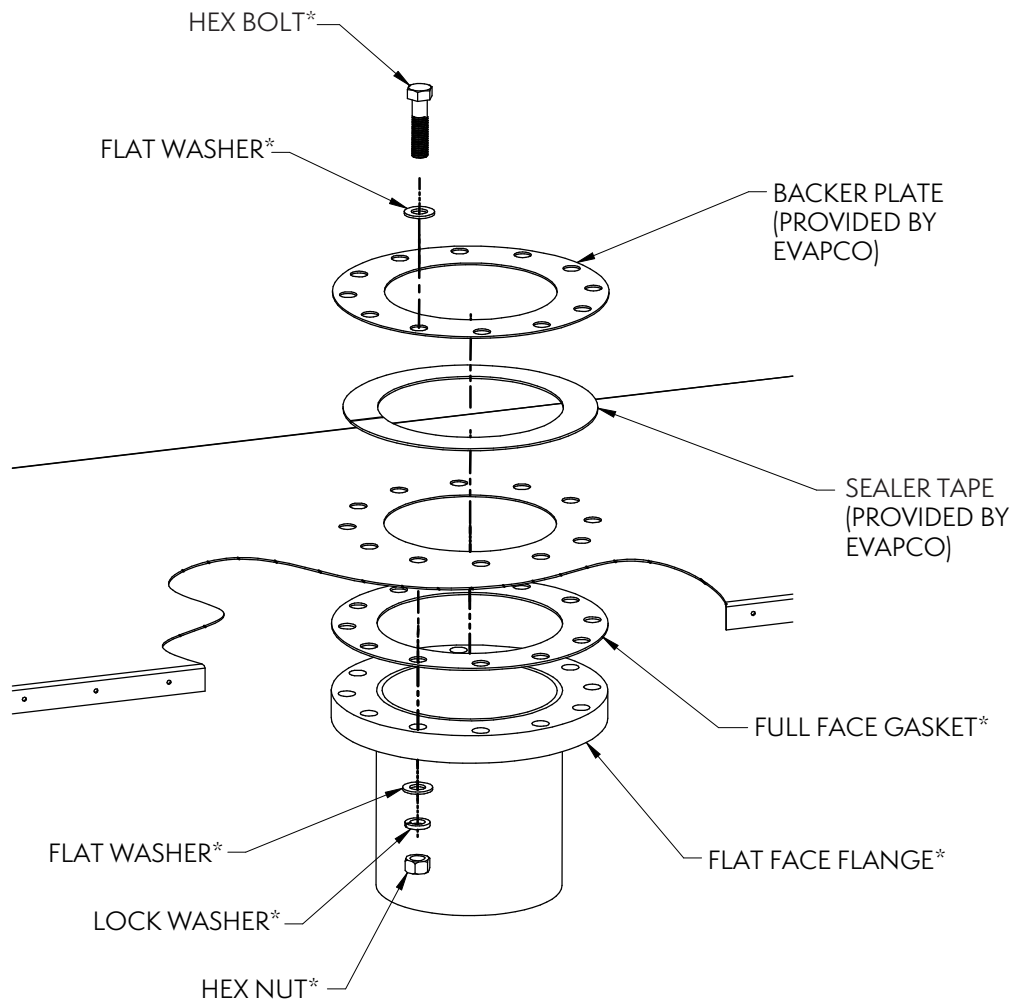

* Supplied by others

Figure 24 – ASME Flange Pattern Sealing

Perimeter Handrail and Ladder Installation

The perimeter handrail and ladder assemblies are shipped in the basin of the unit. In some cases they are shipped separately due to basin accessories that interfere with storage. The perimeter handrails and toe boards are partially assembled prior to shipment for minimal field assembly. If a safety cage is provided with the ladder, it ships along with the ladder.

Perimeter handrail mounting brackets are factory installed, and are located along the edges of the unit, as shown in DETAIL A. The ladder mounting brackets are also factory installed to facilitate mounting the ladder in the field.

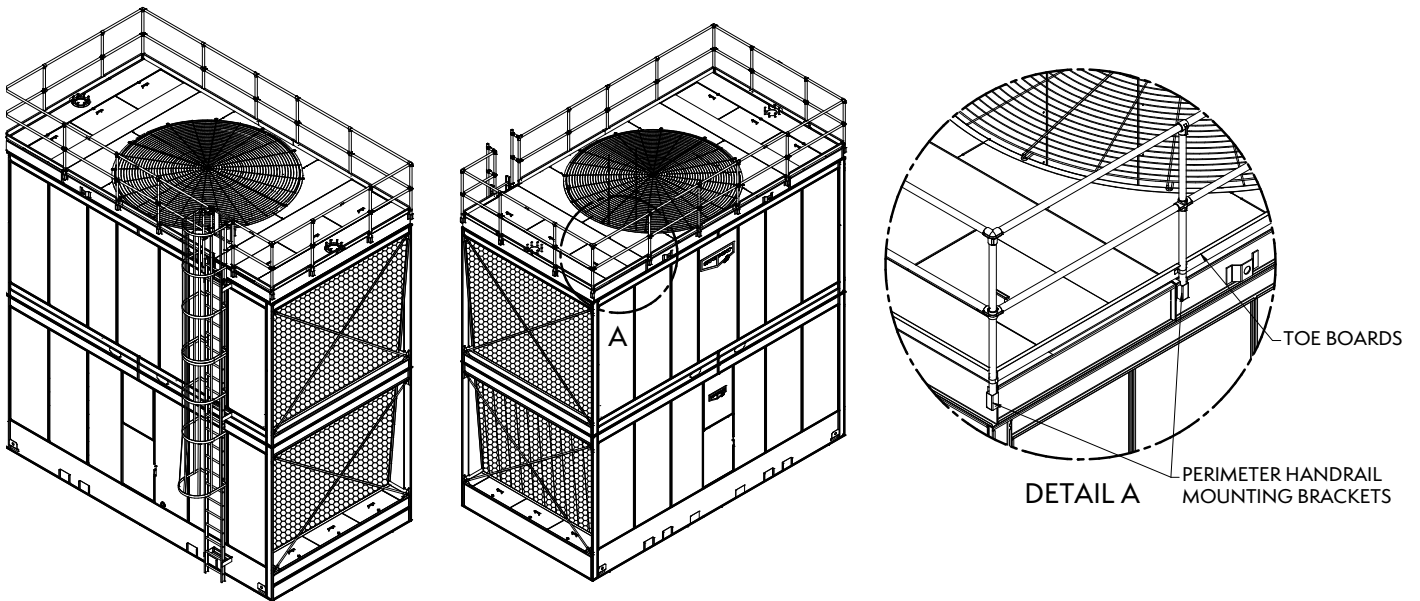

Figure 25 – Perimeter Handrails and Ladder Assembly

Perimeter Handrail and Ladder Installation Continued*

**The section below is only applicable to projects with multiple AXS cells installed right next to each other.*

The perimeter hand rails and ladder assemblies are shipped in the basin of the unit. In the event that multiple AXS towers are being installed right next to one other, the perimeter hand rails will be tied together as shown in DETAIL B. The top channel will also need to be installed to ensure a continuous walking surface as shown in DETAIL C and DETAIL D.

NOTE: Partial unit shown for clarity.

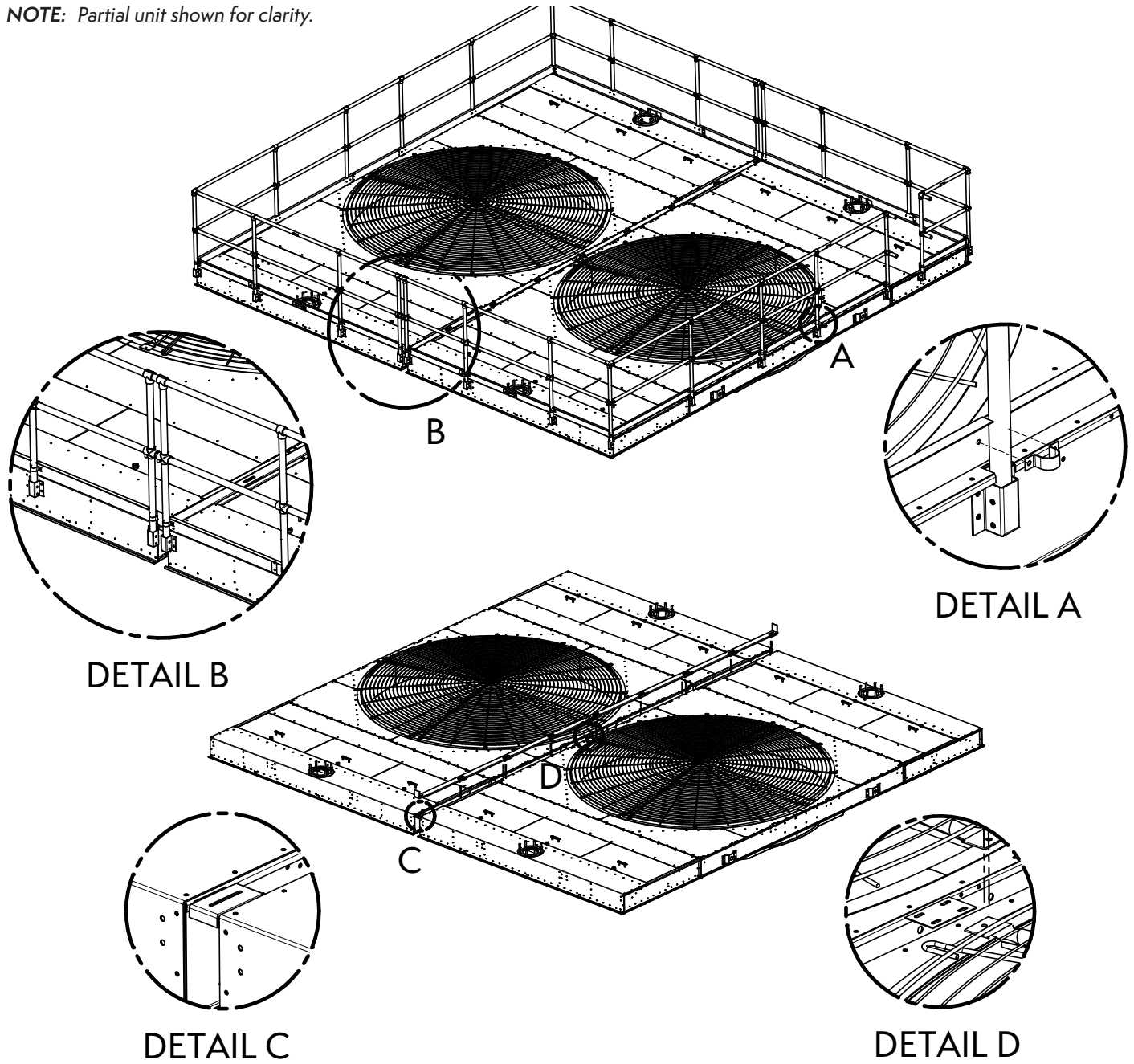

Figure 26 – Multi-Cell Top Channel Installations

Basin Level Platform and Vertical Ladder Installation

If your unit is accessorized with basin level platform assemblies, this equipment is shipped loose to be installed in the field. The platform is fully assembled, less the ladder, prior to shipment to limit the field work to installation. Typically, there are one to two basin level platform assemblies per AXS arrangement, refer to the factory submittal for details. Basin level platforms would be installed after the unit is fully rigged by following the details in **Figures 27 to 31**.

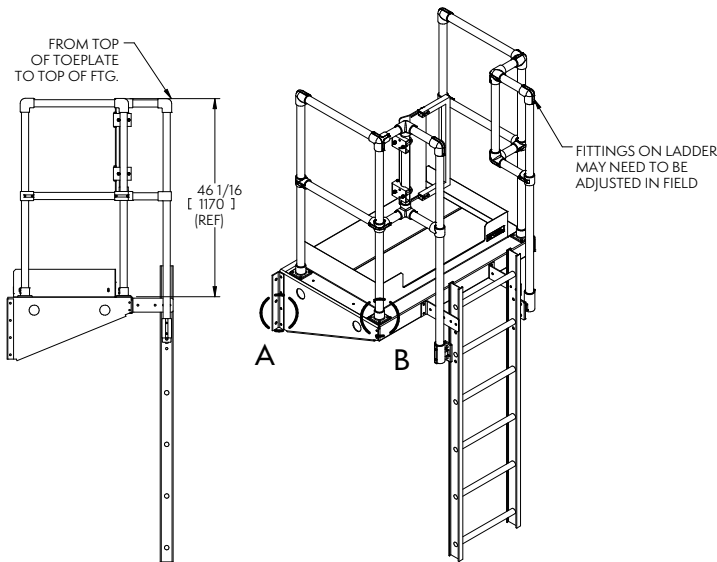

Figure 27 and 28 – General Basin Level Platform Arrangement

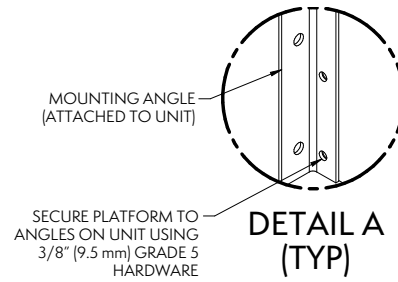

Figure 29 – Platform Securing Detail

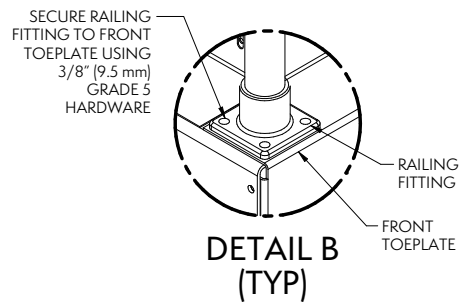

Figure 30 – Railing Securing Detail

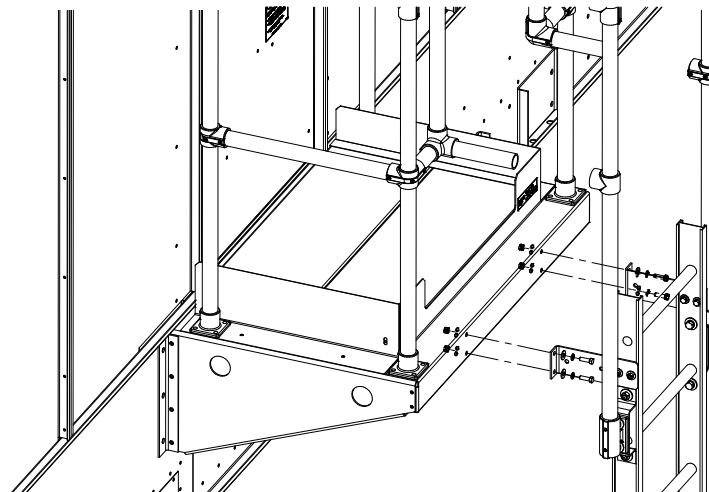

Figure 31 – Ladder Attachment Detail

Firewall Installation

Firewalls are an accessory added to multicell AXS selections that adhere to Factory Mutual Approval requirements. Their purpose is to prevent the spread of fire from one cell to another within the fill media. When the Factory Mutual Approval accessory is included in an AXS order, the firewalls will be shipped loose for installation in the field. For details on firewall installation reference **Figures 32 to 34** in conjunction with **Notes 1 to 2**.

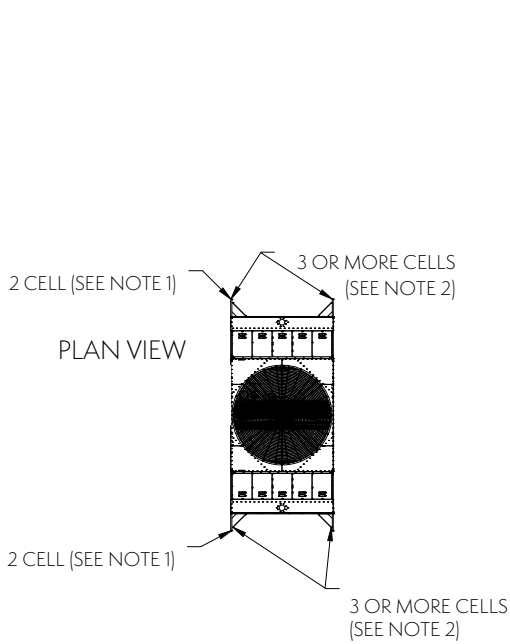

Figure 32 – Plan View of Firewall Installation

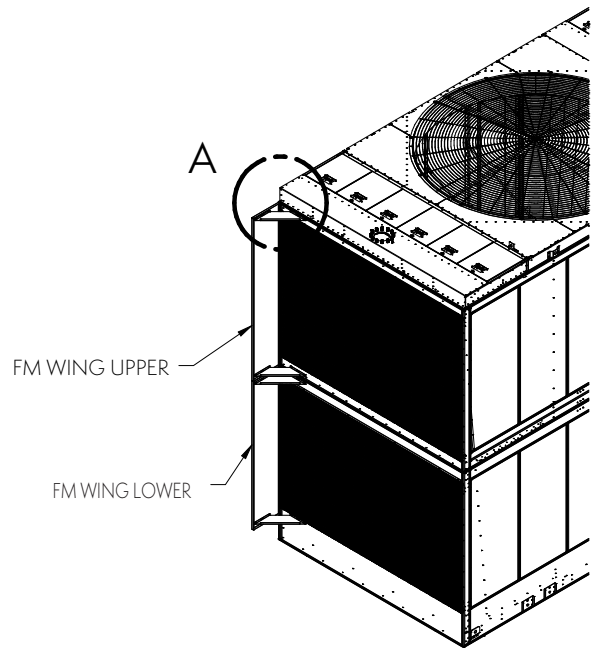

Figure 33 – Firewall Wing Arrangement

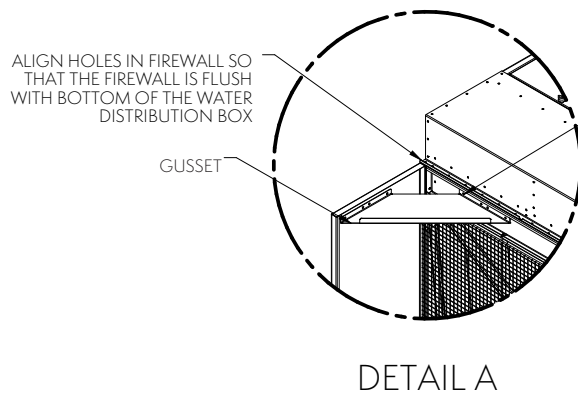

Figure 34 –DETAIL A of Firewall Installation

NOTE 1: On 2-cell AXS installations, one firewall will be installed on one unit between cells.

NOTE 2: On 3-cell or more AXS installations, firewalls will be placed on the center cells, between each end of the cells.

Louver Face Platform and Vertical Ladder Installation

If your unit is accessorized with louver face platform assemblies, this equipment is shipped loose to be installed in the field. The platform is partially assembled prior to shipment to minimize field assembly. Typically, there are two working platforms and ladder assemblies per cell. Refer to your factory submittal for details. The platform and ladder assembly should be attached after the unit is fully rigged, by following the instructions in **Figure 35** and **36**.

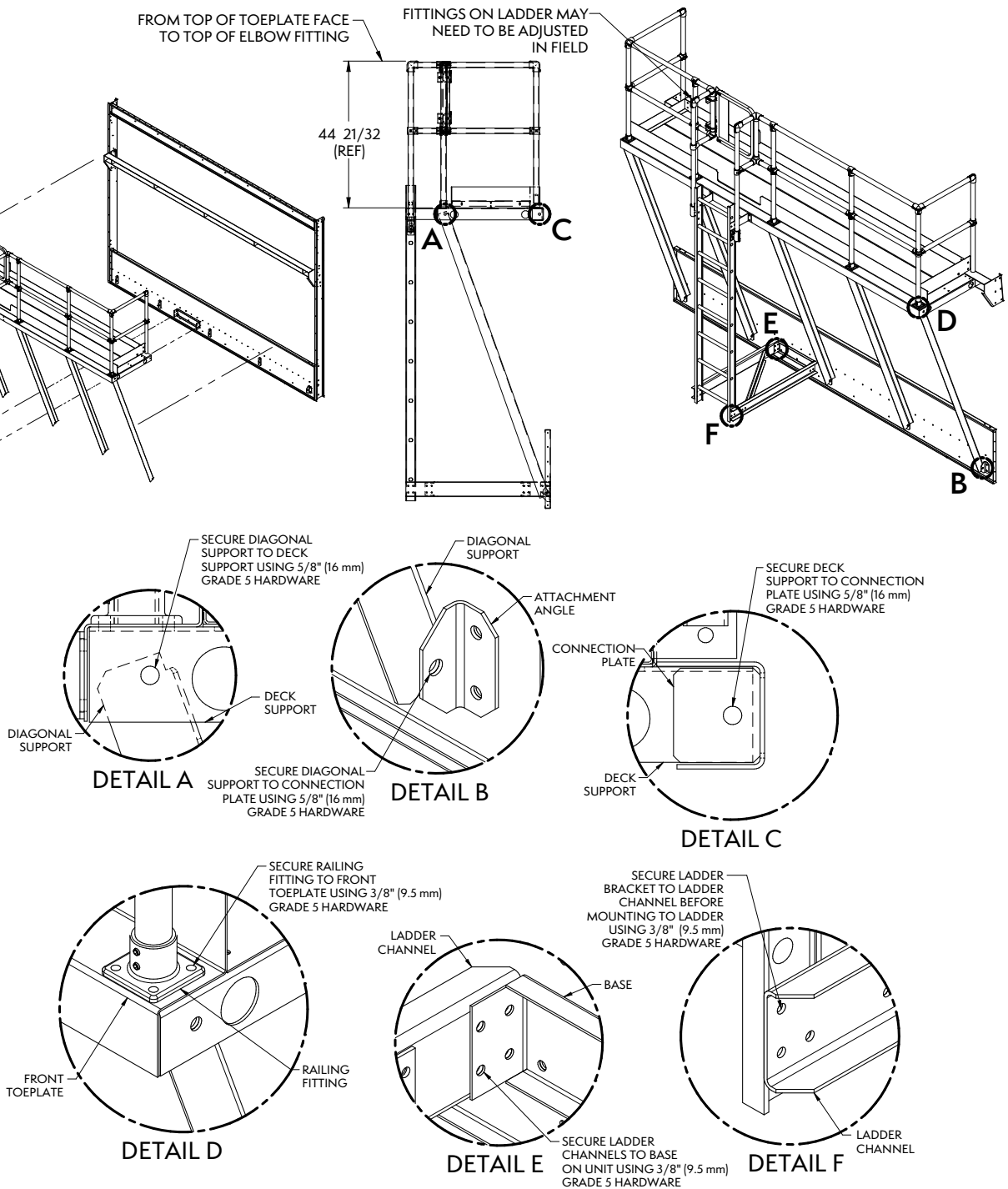

Figure 35 – Single Stack Louver Face Platform and Vertical Ladder Installation

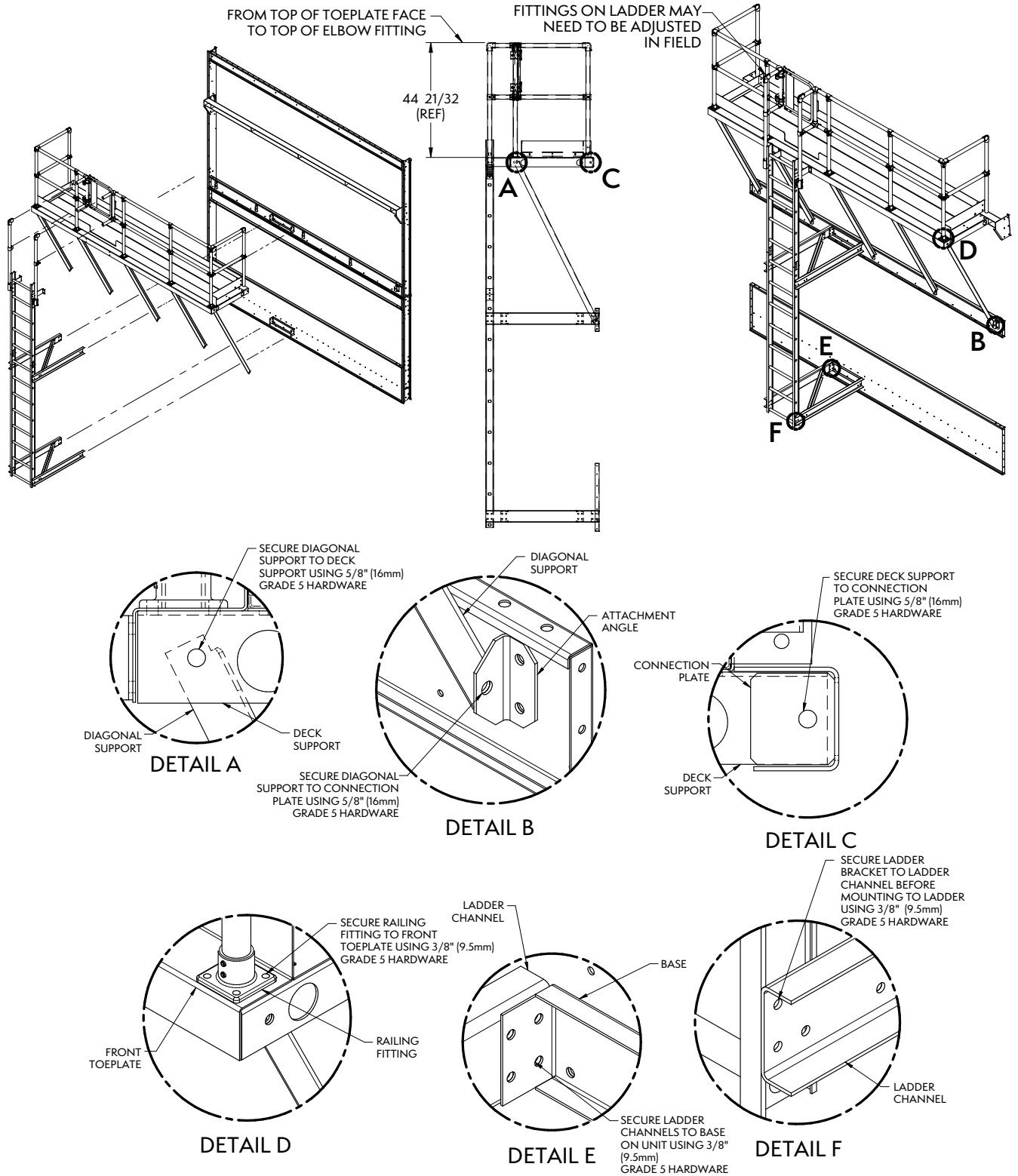

Figure 36 – Double Stack Louver Face Platform and Vertical Ladder Installation

Velocity Recovery (VR) Stack Assembly and Rigging

Some AXS units are designed with Velocity Recovery (VR) stacks. These units are designated with a -VR suffix. The VR stack will ship disassembled in four pieces and packaged separately. Bolt all four sections together on the vertical seams as shown in **Figure 37** below. Ensure that the lifting ears are installed between each of the sections.

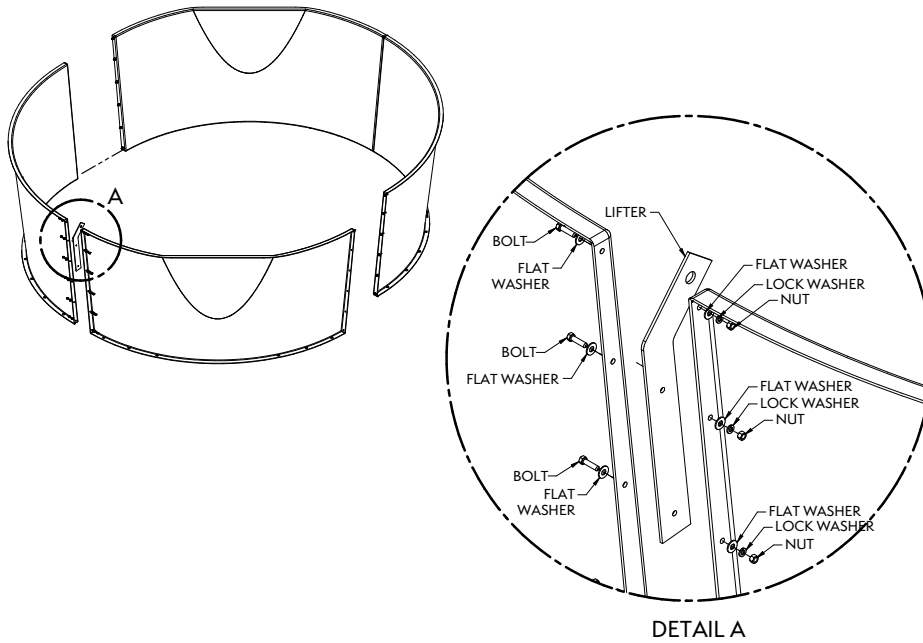

Figure 37 – Assembly of a VR Stack

After the VR stack is fully assembled, lift using all four lifting ears while maintaining a minimum H dimension of 12' (3.7 m) as shown in **Figure 38** below. Slowly lower the VR stack over the unit and attach to the fan deck as shown in **Detail A**.

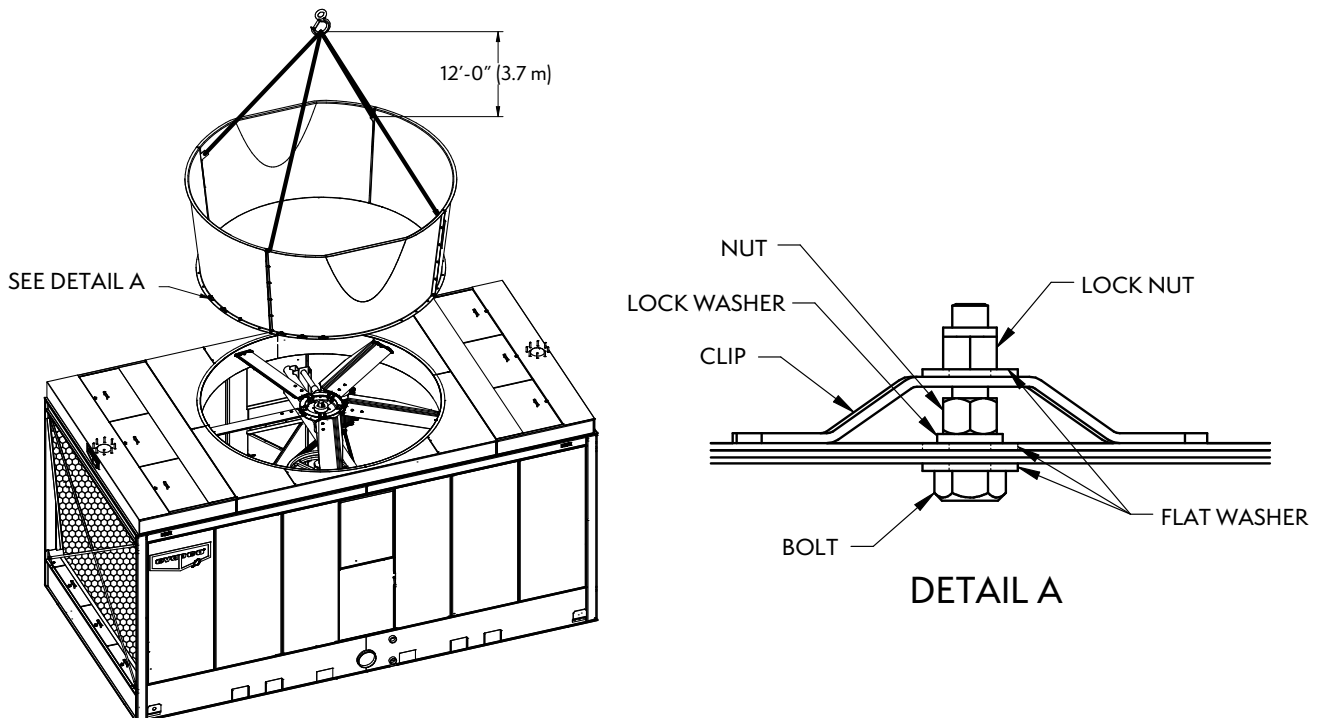

Figure 38 – VR Stack Rigging with a Standard Fan

For units utilizing a Super Low Sound Fan and VR Stack, there will be a small fan cowl extension. The VR stack will attach to the top of the fan cowl. Attach VR stack to the cowl as shown in **Detail A**. Note that this cowl extension will ship loose on units where super low sound fan ships loose. Remove lifting ears after rigging.

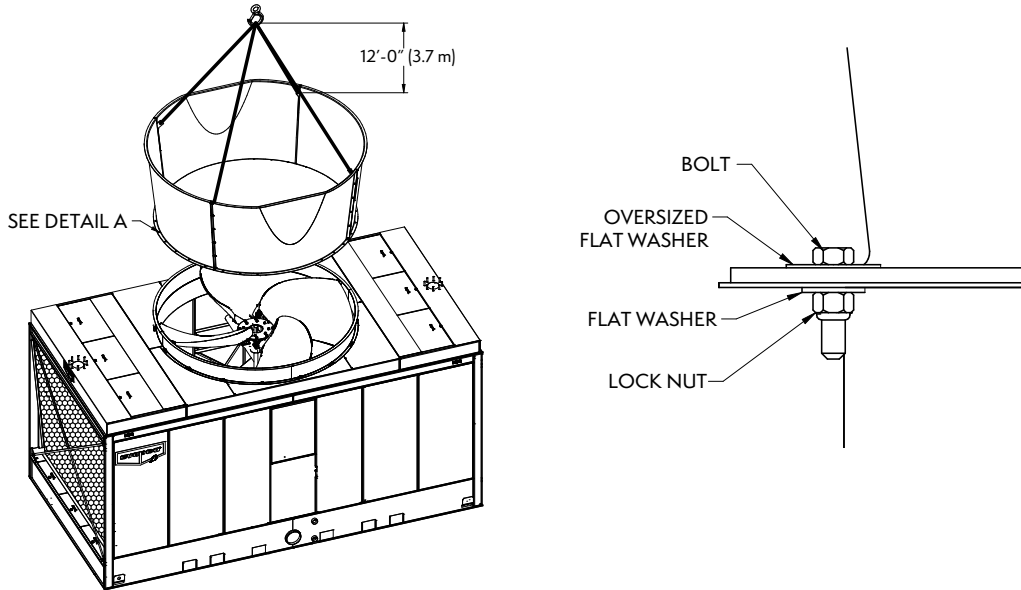

Figure 39 – VR Stack Rigging with a Super Low Sound Fan

General Information – Startup & Maintenance

Remove any chocks that have been placed inside the unit for shipping purposes. Clean all debris from the pan prior to startup. Close and secure all access doors.

Belt Tensioning and Sheave Alignment

All AXS towers which come equipped with Belt Drive systems, have factory mounted motors and belts. The motor is fastened to a sliding base, which facilitates belt tensioning. Check the belt tension by applying moderate hand pressure to the center of the belt, which should deflect approximately 1/2" (13 mm).

As a final check, confirm the sheave alignment by laying a straight edge sheave to sheave. See **Figure 40** for drive system layout.

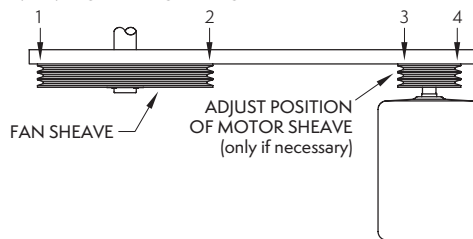

Figure 40 – Sheave Alignment Check

Bleed-off Line

Make sure a bleed line and valve are installed on the pump discharge side of the system piping to a convenient drain. The bleed-off valve should be open.

Adjustment of Float Valve

The float valve should be adjusted to maintain the proper water level as specified in the maintenance instructions. At startup, the pan should be filled to the overflow level.

Strainer

Check the strainer(s) in the pan to make sure they are in the proper location over the pump suction, alongside the anti-vortex hood. Refer to **Figure 41**, which delineates a typical arrangement.

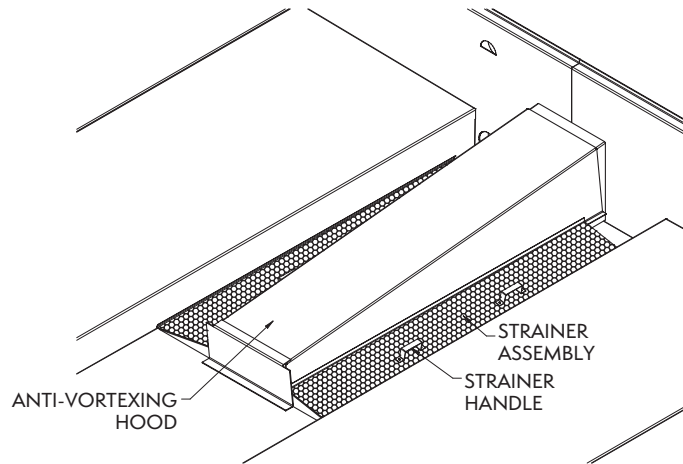

Figure 41 – Strainer Location

Screens

Protective fan screens and fan screen supports are provided across the top of the fan cylinders of all models. Check and tighten all bolts.

Maintenance

Once the installation is complete and the unit is turned on, it is important that it be properly maintained. Maintenance is not difficult or time-consuming but must be done regularly to assure full performance of the unit. Refer to the "Operation and Maintenance Instructions" enclosed with the unit for proper maintenance procedures.

Freeze Protection

Proper freeze protection must be provided if the unit is located in a cold climate. Refer to "Operation and Maintenance Instructions" as well as product bulletins for further information.

External Motor Installation – Gear Drive

1. Mount the motor base assembly to the motor base yoke using (4) 3/8" (10 mm) x 1-1/2" (38 mm) grade 5 bolts, flat washers, lock washers, and nuts on each side of the motor base assembly. Do not fasten any hardware until step 2 is complete.
2. In addition to the grade 5 bolts, install (2) 5/16" (8 mm) spring pins on each side of the motor base assembly as shown in **Figure 42**.
3. Tighten all hardware.

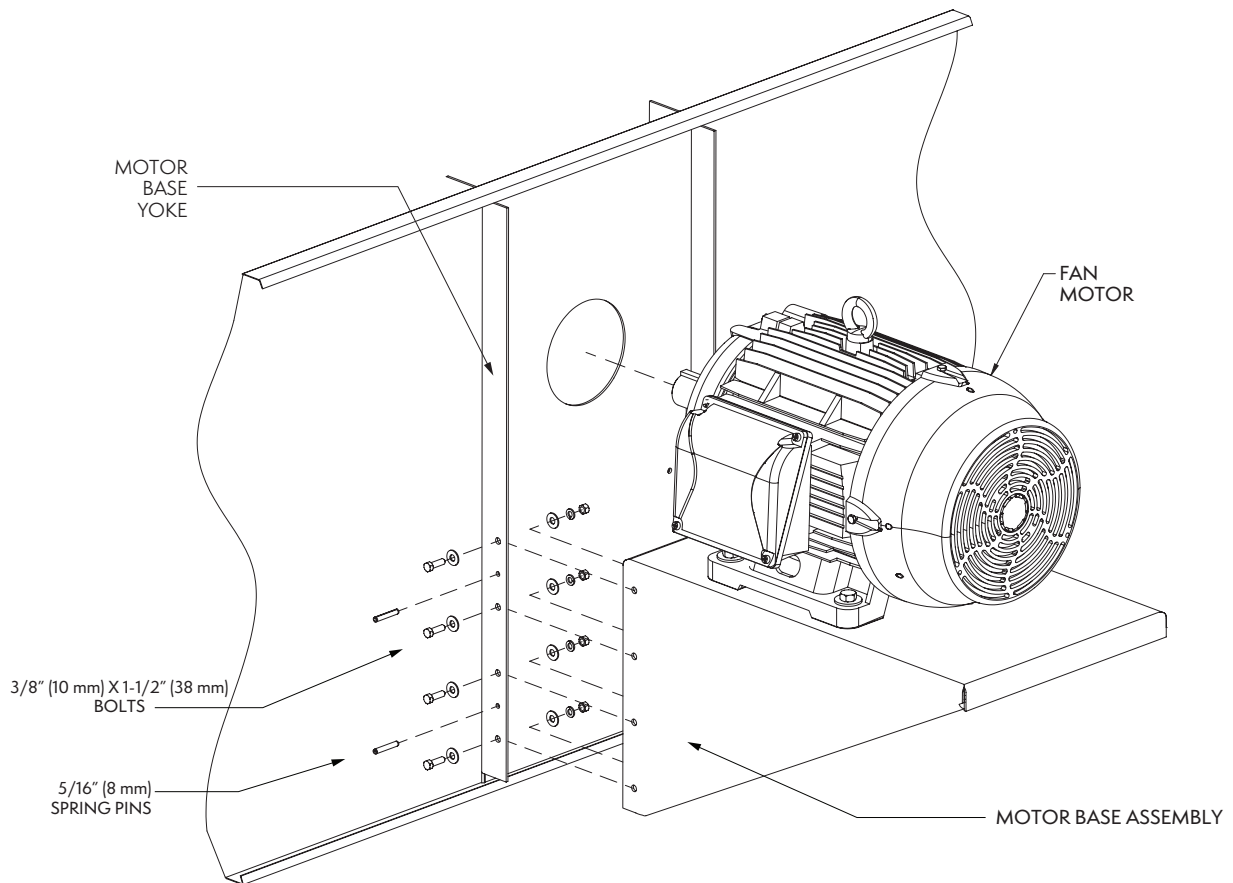

Figure 42 – External Motor Installation for Gear Drive Applications

Internal Motor Mount – Gear Drive and Super Low Sound Fan

AXS units with both Super Low Sound Fans and Gear Drive with Internally Mounted Motor will have short floating shafts (instead of a close coupling). See **Figure 43**.

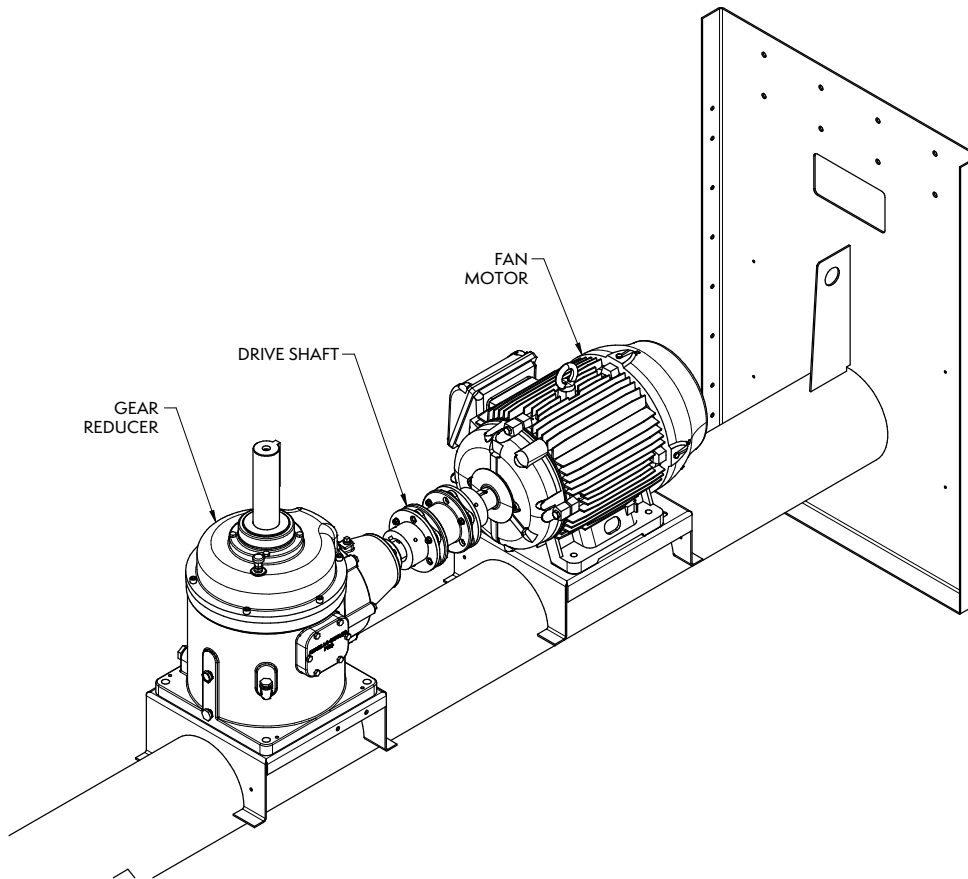

Figure 43 – Internal Motor Mount with Gear Drive and Super Low Sound Fan

Floating Shaft Installation & Alignment

Before proceeding with the steps that follow, please ensure that the motor and the gearbox are level with respect to themselves.

1. Mount the drive shaft with the flexible element assembly on the gear drive input shaft using the supplied 3/8" (10 mm) hardware. All bolts, lock washers and nuts are supplied with the drive shaft kit.
2. Insert steel bushings into the composite flexible elements on the gear and motor side.
3. Mount the drive shaft with the flexible element assembly on the motor output shaft using the supplied 3/8" (10mm) hardware. All bolts, lock washers and nuts are supplied with the drive shaft kit.
4. Torque requirements for the bolts are listed in **Table 6**; these values are dependent upon the shaft model.

Shaft Model	Torque Requirement
LR_350	400 in-lbs (33ft-lbs 54 Nm)
LR_375	400 in-lbs (33ft-lbs 54 Nm)
LR_450	145 in-lbs (12 ft-lbs 16 Nm)
LR_485	240 in-lbs (20 ft-lbs 27 Nm)
Amarillo Model 52	100 in-lbs (8.33 ft-lbs 11.30 Nm)
Amarillo Model 60	310 in-lbs (25.83 ft-lbs 35.03 Nm)

Table 6 – Torque Requirements for Floating Shaft Assemblies

5. Check angular and axial misalignment between the drive shaft and both the motor and gear couplings (see **Figure 44** and **45**).

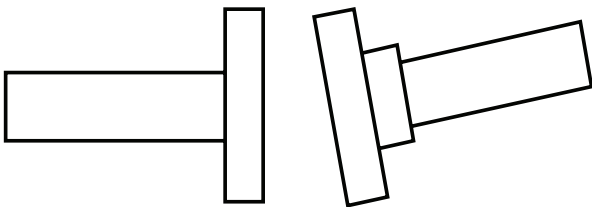

Figure 44 – Angular Misalignment

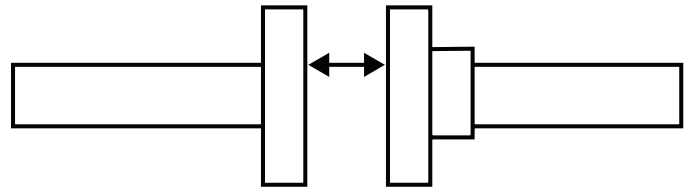

Figure 45 – Axial Misalignment

6. Check angular misalignment with a dial indicator on **gear drive side**, as shown in **Figure 46**.
7. Attach the dial indicator support to the drive shaft and position the indicator tip to read off the opposite side flange.
8. With the dial indicator set to zero, rotate the shaft 360° and record the indicator readings at 90° increments.
9. For Amarillo shafts, the range between the minimum and maximum values should be less than 0.030 inches (0.76 mm) for the Model 52, and less than 0.035 inches (0.89 mm) for the Model 60. Range between minimum and maximum values for the LRF_450 shaft should be less than 0.010 inches (0.25 mm). Acceptable angular alignment shown in **Table 7**.

Shaft Model	Angular Alignment
LR_350	0.010 in - (0.25 mm)
LR_375	0.010 in - (0.25 mm)
LR_450	0.010 in - (0.25 mm)
LR_485	0.010 in - (0.25 mm)
Amarillo Model 52	0.030 in - (0.76 mm)
Amarillo Model 60	0.035 in - (0.89 mm)

Table 7 – Angular Alignment

10. When the angular alignment is within the acceptable ranges as mentioned in step 9, securely tighten all gear drive hardware.
11. Repeat steps 7, 8, and 9 to check angular misalignment with a dial indicator on **motor side**.
12. When the angular alignment is within the acceptable ranges as mentioned in step 9, securely tighten all motor hardware.
13. Recheck alignment with the dial indicator at both the gear drive and the motor ends to ensure that misalignment did not occur during final bolt tightening.

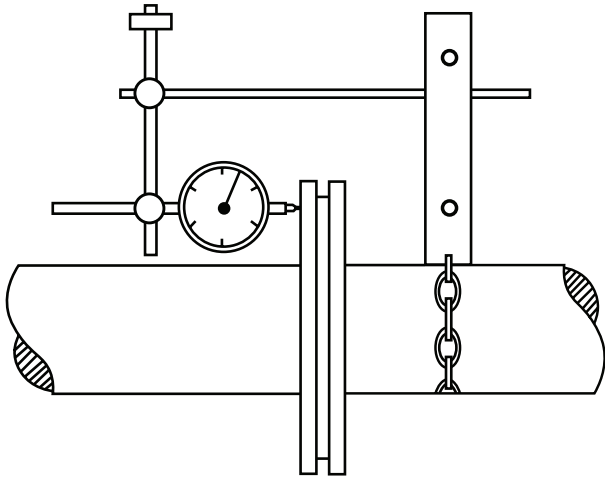

Figure 46 – Angular Misalignment Check with Dial Indicator

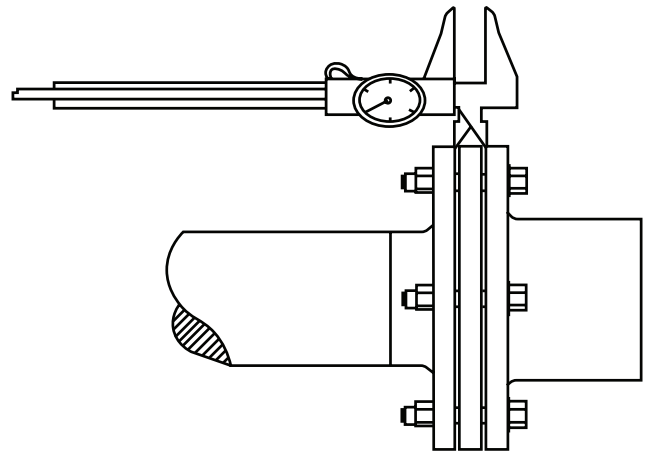

Figure 47 – Axial Misalignment Check with Dial Caliper

14. Check axial misalignment (hub separation) with the dial caliper on both the gear drive side and the motor side (See **Figure 47**).
15. Without rotating the shaft, measure the gap between the shaft flange and the hub flange on both ends. Take four (4) readings around the perimeter at 90° intervals.
16. For the Amarillo shafts, the nominal gap is 0.785 inches (19.94 mm). If the average of the four values for each end measured varies from the nominal gap by +/- 0.030 inches (0.76 mm), then the hubs must be repositioned. For the LR_450 shafts, the nominal gap is to be 0.430 inches (10.92 mm). If the average of the four values for each end measured varies from the nominal gap by +/- 0.010 inches (0.25 mm), then the hubs must be repositioned. Acceptable axial alignment shown in Table 8.

Shaft Model	Nominal Gap	Tolerance
LR_350	0.43 in (10.92 mm)	+/- 0.01 in (+/- 0.25 mm)
LR_375	0.54 in (13.72 mm)	+/- 0.01 in (+/- 0.25 mm)
LR_450	0.43 in (10.92 mm)	+/- 0.01 in (+/- 0.25 mm)
LR_485	0.60 in (15.24 mm)	+/- 0.02 in (+/- 0.51 mm)
Amarillo Model 52	0.785 in (19.94 mm)	+/- 0.03 in (+/- 0.76 mm)
Amarillo Model 60	0.785 in (19.94 mm)	+/- 0.03 in (+/- 0.76 mm)

Table 8 – Axial Alignment

17. Your floating shaft assembly installation is now complete.

NOTE: All floating shafts ship loose for field installation and alignment by others.

Appendix

Units are provided with match markings on each section. Standard match marking location is at the rigging seam on the long side. Standard match marking designation is shown below:

XX - Y

└─ Cell Number Designator
└─ Last 2 Digits of Serial Number

Example:

Serial Number: 23p123456 Number of Cells: 1

↓

Match Marks: Cell #: 56-1

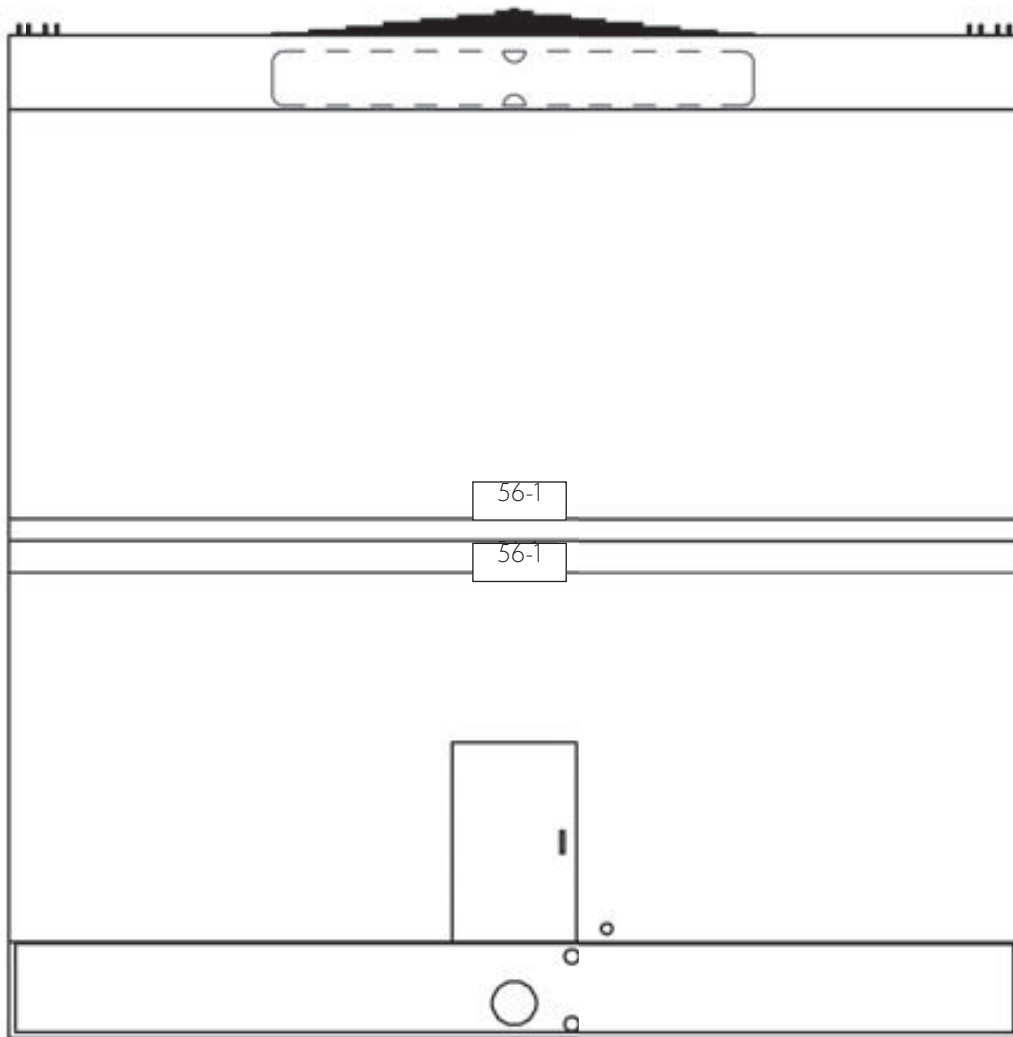

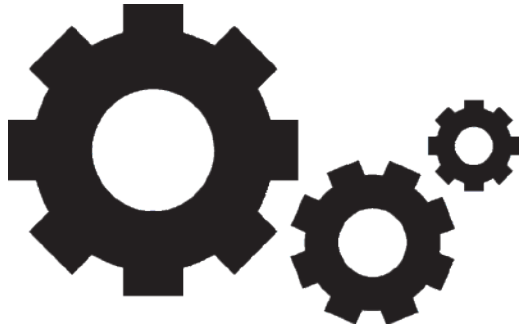

FOR EVAPCO AUTHORIZED PARTS AND SERVICE, CONTACT YOUR LOCAL EVAPCO REPRESENTATIVE OR THE LOCAL SERVICE CENTER



Mr. GoodTower®



EVAPCO, Inc. — World Headquarters & Research/Development Center

P.O. Box 1300 • Westminster, MD 21158 USA
410.756.2600 • marketing@evapco.com • evapco.com

North America

EVAPCO, Inc.
World Headquarters
Westminster, MD USA
410.756.2600
marketing@evapco.com

EVAPCO East
Taneytown, MD USA

EVAPCO East
Key Building
Taneytown, MD USA

EVAPCO Midwest
Greenup, IL USA
217.923.3431
evapcomw@evapcomw.com

Evapcold Manufacturing
Greenup, IL USA

EVAPCO Newton
Newton, IL USA
618.783.3433
evapcomw@evapcomw.com

EVAPCO West
Madera, CA USA
559.673.2207
contact@evapcowest.com

EVAPCO Alcoil, Inc.
York, PA USA
717.347.7500
info@evapco-alcoil.com

EVAPCO Iowa
Lake View, IA USA

EVAPCO Iowa
Sales & Engineering
Medford, MN USA
507.446.8005
evapcomn@evapcomn.com

EVAPCO LMP ULC
Laval, Quebec, Canada
450.629.9864
info@evapcolmp.ca

EVAPCO Select Technologies, Inc. Bel-
mont, MI USA
844.785.9506
emarketing@evapcoselect.com

**Refrigeration Vessels &
Systems Corporation**
Bryan, TX USA
979.778.0095
rvs@rvscorp.com

Tower Components, Inc.
Ramseur, NC USA
336.824.2102
mail@towercomponentsinc.com

EvapTech, Inc.
Edwardsville, KS USA
913.322.5165
marketing@evaptech.com

EVAPCO Dry Cooling, Inc.
Bridgewater, NJ USA
908.379.2665
info@evapcodc.com

EVAPCO Dry Cooling, Inc.
Littleton, CO USA
908.895.3236
info@evapcodc.com

EVAPCO Power México S. de R.L. de C.V.
Mexico City, Mexico
(52) 55.8421.9260
info@evapcodc.com

Asia / Pacific

**EVAPCO Asia Pacific
Headquarters**
Baoshan Industrial Zone Shanghai, P.R. China
(86) 21.6687.7786
marketing@evapcochina.com

**EVAPCO (Shanghai)
Refrigeration Equipment Co., Ltd.**
Baoshan Industrial Zone, Shanghai, P.R. China

**EVAPCO (Beijing)
Refrigeration Equipment Co., Ltd.**
Huairou District, Beijing, P.R. China
(86) 10.6166.7238
marketing@evapcochina.com

**EVAPCO Air Cooling Systems
(Jiaxing) Company, Ltd.**
Jiaxing, Zhejiang, P.R. China
(86) 573.8311.9379
info@evapcochina.com

EVAPCO Australia (Pty.) Ltd.
Riverstone, NSW, Australia
(61) 02.9627.3322
sales@evapco.com.au

**EvapTech (Shanghai)
Cooling Tower Co., Ltd**
Baoshan District, Shanghai, P.R. China.
Tel: (86) 21.6478.0265

EvapTech Asia Pacific Sdn. Bhd.
Puchong, Selangor, Malaysia
(60) 3.8070.7255
marketing-ap@evaptech.com

Europe | Middle East | Africa

**EVAPCO Europe
EMENA Headquarters**
Tongeren-Borgloon, Belgium
(32) 12.39.50.29
info@evapco.be

EVAPCO Europe BV
Tongeren-Borgloon, Belgium

EVAPCO Europe, S.r.l.
Milano, Italy
(39) 02.939.9041
evapcoeuropa@evapco.it

EVAPCO Europe, S.r.l.
Sondrio, Italy

EVAPCO Europe A/S
Aabybro, Denmark
(45) 9824.4999
info@evapco.dk

EVAPCO Europe GmbH
Meerbusch, Germany
(49) 2159.69560
info@evapco.de

EVAPCO Middle East DMCC
Dubai, United Arab Emirates
(971) 56.991.6584
info@evapco.ae

Evap Egypt Engineering Industries Co.
A licensed manufacturer of EVAPCO, Inc.
Nasr City, Cairo, Egypt
(202) 10 054 32 198
evapco@tiba-group.com

EVAPCO S.A. (Pty.) Ltd.
A licensed manufacturer of EVAPCO, Inc.
Isando, South Africa
(27) 11.392.6630
evapco@evapco.co.za

South America

EVAPCO Brasil
Equipamentos Industriais Ltda.
Indaiatuba, São Paulo, Brazil
(55) 11.5681.2000
vendas@evapco.com.br

FanTR Technology Resources
Itu, São Paulo, Brazil
(55) 11.4025.1670
fantr@fantr.com

TECHNOLOGY FOR THE FUTURE, AVAILABLE TODAY

Visit EVAPCO's websites: www.evapco.eu / www.mrgoodtower.eu